



Since 1977

Energy efficiency & **MAX**imum performance

# AIR DRYER



**MODEL:** *EDRYHT0028*  
*EDRYHT0056*  
*EDRYHT0091*  
*EDRYHT0134*  
*EDRYHT0246*  
*EDRYHT0402*

# Contents

GENERAL SAFETY INFORMATION .....	1
READ PRIOR TO STARTING THIS EQUIPMENT .....	1
DESCRIPTION .....	2
INSTALLATION .....	3
OPERATION .....	5
MAINTENANCE .....	6
FLOW SCHEMATIC .....	7
TROUBLESHOOTING .....	8

## **GENERAL SAFETY INFORMATION**

1. This equipment is a pressure-containing device. Don't exceed maximum operating pressure as shown on equipment serial number tag.
2. This equipment requires electricity to operate. Install equipment in compliance with national and local electrical codes.
3. Disconnect power supply to equipment when performing any electrical service work.

## **READ PRIOR TO STARTING THIS EQUIPMENT**

1. This equipment has been thoroughly checked, packed and inspected before leaving out plant
2. This equipment is shipped to accommodate a forklift truck. When installing this equipment, move it by means of a forklift. Never lift it by hooking on to the air inlet and outlet connections.
3. Air-cooled units – Free air flow - Ambient air should be free to flow across the refrigeration condenser. Do not block either side of the cabinet. Leave at least 1.5m clearance for free air flow. The ambient temperature is to be within the operating parameters of 2°C to 40°C.

## **DESCRIPTION**

### **Function**

Compressed air enters the air-to-air heat exchanger and is pre-cooled by the chilled outgoing air. The air then enters the air-to-refrigerant heat exchanger where it is further cooled by the refrigeration system. As the air is cooled, water vapor condenses into liquid droplets. The air and entrained water droplets then enter the separator where liquid water is removed. In addition, the air is filtered of all solid particles three microns and larger. Clean, dry compressed air leaving the dryer minimizes maintenance and repair of pneumatic distribution, instrument and control, and actuation devices, reduces product contamination, and increases productivity.

### **Working flow**

Compressed air, saturated with water vapor, enters the dryer and is pre-cooled by the outgoing refrigerated air in an air-to-air heat exchanger (pre-cooler). It is a shell and tube type with cold air in the shell and the warm air in the tube side. In the pre-cooler, the warm incoming air is pre-cooled and the outgoing refrigerated air is warmed, this reduces the amount of heat that will have to be removed later by the refrigeration system, providing a more energy efficient dryer. The Pre-Cooled air enters the evaporator, where heat from the compressed air is transferred to the cold refrigerant. The compressed air is therefore cooled to a predetermined temperature, allowing water vapor to condense into liquid droplets. The compressed air then flows to the moisture separator, where the

condensed moisture, oil and solids are separated from the compressed air and discharged from the system by an automatic condensate drain trap. The cold compressed air, enters the shell side of pre-cooler. By removing heat from the incoming air, the outgoing air is reheated.

In the refrigeration system, the compressor compresses low temperature, low-pressure refrigerant into high temperature, high-pressure gas. The compressed refrigerant gas flows through the discharge line to a condenser, where the gaseous refrigerant is condensed into a high-pressure liquid, by exchanging heat to the cooling airflow. The high-pressure liquid refrigerant reduces to a low pressure, low temperature mixture of liquid and vapor after passing through the thermostatic expansion valve and evaporator as it takes heat from the compressed air. The low-pressure refrigerant gas leaves the evaporator and flows to the liquid refrigerant accumulator, ensuing that only gas is returned to compressor. The accumulator prevents liquid refrigerant from entering the compressor and causing severe damage to the compressor. Refrigerant travels through the suction line to the compressor where the refrigeration cycle again starts.

## **INSTALLATION**

### **Mounting**

1. A dry, well-ventilated area is the best location for installation of the dryer. It also should be in an area where the ambient temperature will not exceed 40°C or fall below 2°C.
2. A dryer should be kept at a distance from the air compressor in order to prevent

the vibration of the compressor from interfering with the dryer's operation.

3. Mount dryer on firm level surface.

4. Automatic drain outlet should be connected to the plant drainage system in order to prevent condensate from polluting plant.

5. For typical placement in a compressed air system, see drawing back.

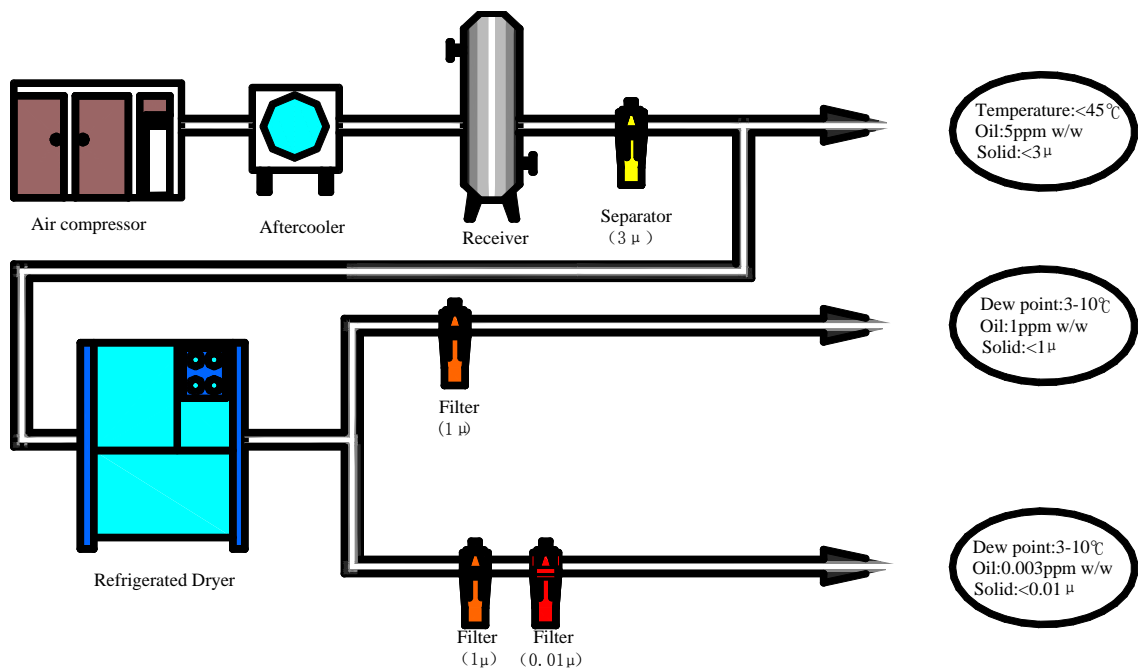

### Typical Piping connection

Three -valve bypass line should be installed before the dryer air inlet valve and after the dryer air outlet valve. This bypass valve always be install to permit the continued use of the plant compressed air system during any dryer maintenance or servicing operations.

### Power and electrical connections

1. Be sure that voltage to unit is as marked on unit serial number tag.
2. Range of voltage fluctuation will not exceed 10% of rated voltage.

3. Electrical entry in through electrical connection entry hole in electrical enclosure. Connect power to proper terminals.

## OPERATION

### Preparation for start-up

1. Be sure that voltage to unit, air inlet pressure, air inlet temperature, air flow are as marked on unit serial number tag.
2. Blow off the compressed air lines for a few minutes to remove welding slag.

### Start-up

1. Check the low refrigeration pressure gauge, it should indicate higher than 0.25MPa.
2. If the voltage is at normal range, open electric control box and close air switch.
3. Press the control button “ON” to start.

### Operation

1. Take note of refrigerant gauge indication at normal range:

The low refrigeration pressure gauge should indicate

Refrigerant	R22	R134a	R404A	R407C
L-Pessure	0.35~0.45MPa	0.18~0.25MPa	0.45~0.55MPa	0.30~0.40MPa

If pressure is below this range please contact local service.

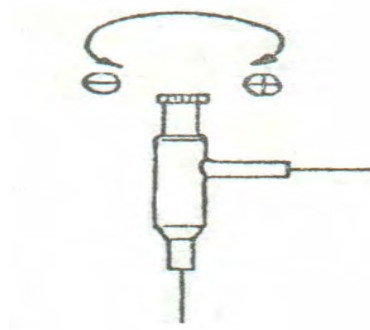

**Notice proceeding**

1. Note running of the refrigeration compressor. Check and remove troubleshooting in time.
2. Don't start-up and shutdown frequently, dryers should restarted after 10 minutes.

**Shutdown**

Close the dryer air inlet valve and press the control button to shut, then disconnect the power and close the water supply valve.

**MAINTENANCE**

**Air-cooled condenser**

Ambient air should be free to flow across the refrigeration condenser for heat exchanging. Do not locate the dryer in direct sunlight. Air-cooled condenser should be cleaned with compressed air periodically.

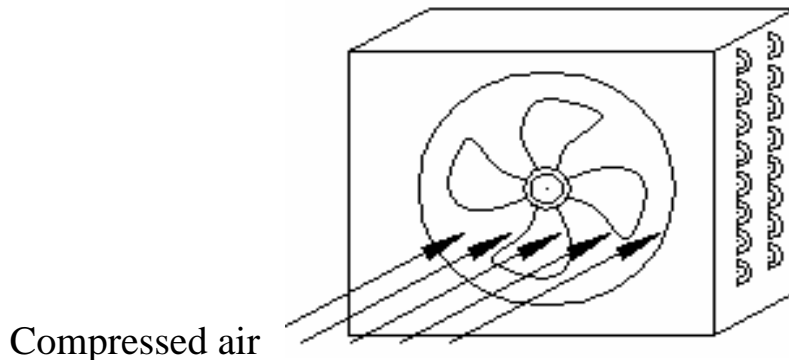



### Automatic condensate drain

Monthly flush out accumulated sludge and dirt in the automatic condensate drain. Procedure for clean drains:

- a. Close manual valve ahead of drain.
- b. Depressurize drain by loosening shell bolt.
- c. Remove shell bolt and detach the shell, take filter core out and clean it with brush and water.
- d. Reassemble the core and the shell. Then open the manual valve ahead of drain.

### Electric apparatus

Check parts in the electric apparatus box and removes troubleshooting in time.

## FLOW SCHEMATIC

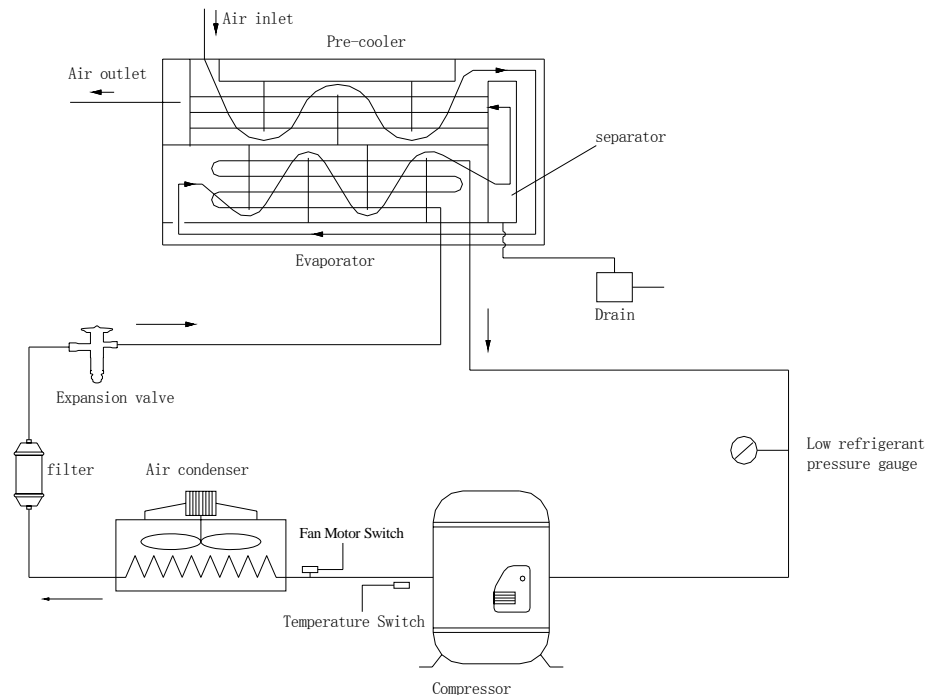

**Flow diagram**

## TROUBLESHOOTING

	POSSIBLE CAUSE (S)	CORRECTIVE ACTION
Dryer not running	Power failure	Check power to unit
	Temperature switch is disconnected	Reset
	Faulty wiring, loose terminals	Have electrician check electrical connections
	Compressor motor damage	Have compressor check and replace
	Contactors damage	Have contactor check and replace
	Refrigerant leaks	Leak test and repair, refrigerant to be re-filled.
Compressor run discontinues	Lack of refrigerant	Refrigerant to be re-filled.
Condense pressure too high	Ambient temperature too high	Check minimum/maximum temperature ranges
	Fan motor switch improperly set	Set properly
	Air-cooled models – Dirty, clogged condenser fins, obstructed air flow across condenser	Clean condenser and check for free air flow
	Too much refrigerant	Let out excessive refrigerant
	Air in refrigerated cycle system	Remove air in system
Condense pressure too low	Fan motor switch improperly set	Set properly
Evaporate pressure too high	Thermostatic expansion valve open degree too large	Adjust Thermostatic expansion valve correctly
	Thermostatic expansion valve damage	Replace Thermostatic expansion valve
Evaporate pressure too low	Refrigerant Leak	Refrigerant to be re-filled.
System noise	Compressor sounds abnormally	Replace damaged component
	Thermostatic expansion valve sounds	Check refrigerant capacity and replace filter

<b>High pressure drop across dryer</b>	<b>Excessive air flow</b>	<b>Check flow rate and select dryer newly</b>
	<b>Freezing of moisture in evaporator because of refrigeration system improperly functioning</b>	<b>Adjust hot gas bypass valve clockwise</b>
	<b>Pipeline diameter too small Pipeline too long Pipeline elbows too many</b>	<b>Install new pipeline</b>
	<b>Inlet/Outlet valve not open completely</b>	<b>Open inlet/outlet valve completely</b>
	<b>Pipeline leak</b>	<b>Leak test</b>
<b>Refrigeration system not functioning properly</b>	<b>Low inlet air pressure High ambient air temperature High inlet air temperature High air flow</b>	<b>Check Dryer Selection</b>
	<b>Air bypass valve open</b>	<b>Close air bypass valve</b>
	<b>drain troubleshooting a. Manual valve not open b. Drain jam or damage Drain line higher than drain condensate outlet</b>	<b>Open manual valve Clean and replace drain Install condensate line Newly</b>
<b>Stop at running process</b>	<b>Fuse burn off</b>	<b>Replace fuse</b>
	<b>Condense pressure too high bring on high pressure switch open Ambient temperature too high Inlet temperature too high Air flow too high</b>	<b>Adjust working status or select dryer newly</b>
	<b>Evaporate pressure too low bring on low pressure switch open Ambient temperature too low Thermostatic expansion valve opening degree too small or jam Refrigerant leak</b>	<b>Adjust hot gas bypass valve regulator clockwise Adjust or replace thermostatic expansion valve Replace dryer/filter Check leak</b>
	<b>Electric component damage</b>	<b>Replace damaged component</b>
	<b>Compressor damage</b>	<b>Replace compressor</b>