

| | | | | | |
|----|---------------|-------------|---------------|----------|----|
| 01 | UPDATED PRINT | DESCRIPTION | HO# 121242 00 | 10/28/12 | FA |
| ED | | | DN | DATE | BY |

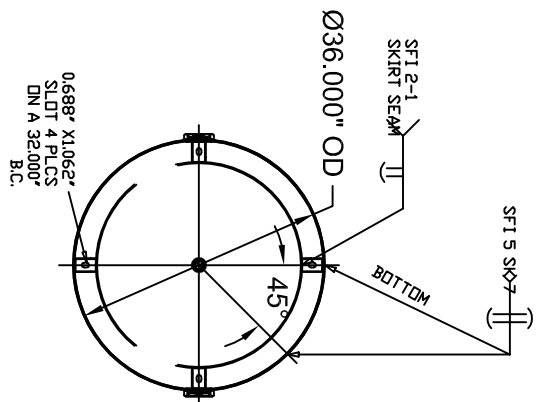

| ITEM | P/N | DESCRIPTION | MATERIAL | QTY |
|------|---------|-------------|----------|-----|
| 1 | H361873 | HEAD 36\"/> | | |

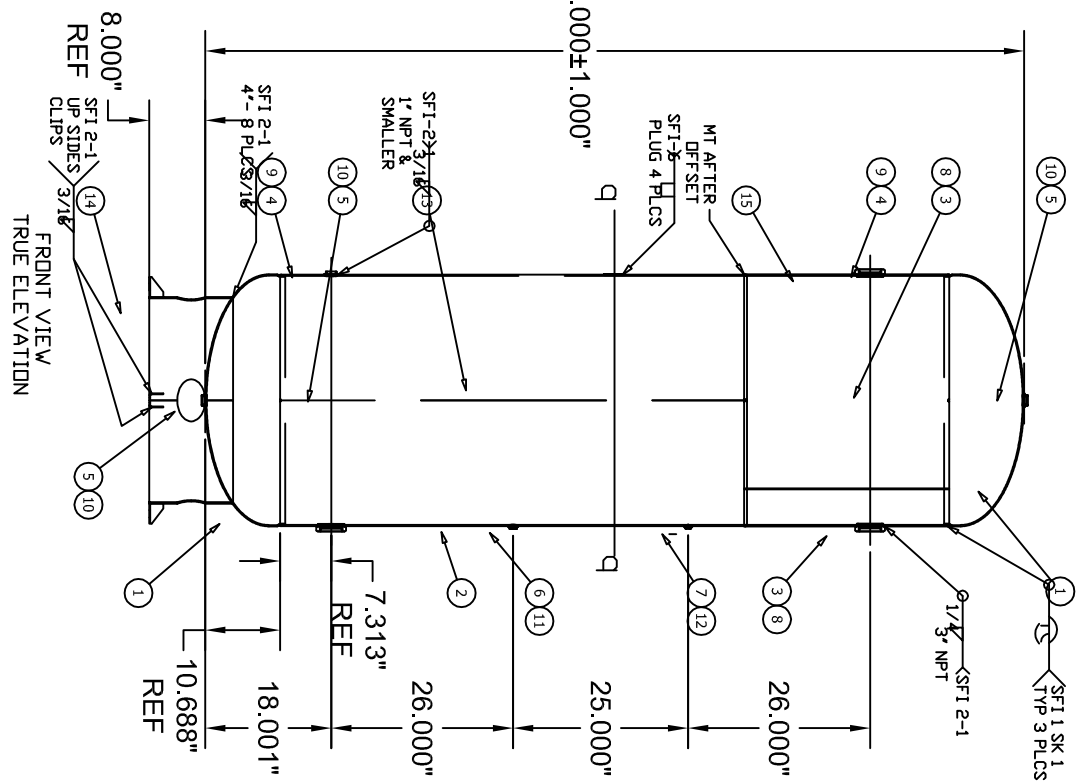
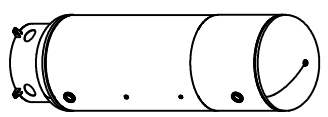

**SHELL CUT SHEET IS REFERENCE ONLY
 **SHIPPING WEIGHT: 915#
 **IMPACT TEST EXEMPT PER US 2010
 36\"/>

| RELEASED TO PRODUCTION | | CALCULATED MINIMUMS | |
|------------------------|------------------|---------------------|-------|
| SALES ORDER# | | HEAD THK: | .162 |
| RELEASE DATE: | | SHELL THK: | .197 |
| NB/SERIAL# | | | |
| HEAD THK: | .176 | MIN. C.A.: | --- |
| SHELL THK: | .200 | NON. C.A.: | --- |
| MATL BR: | YES | STAMP: | U |
| VOLUME: | 500 APPROX | GAU: | |
| CRN: | L4039,567801234T | TEST: | HYDRO |
| REF: | | TEST: | RNBU |

| | | | | |
|----------|----|------|-------|----------|
| DATE | BY | CHKD | APP'D | REVISION |
| 10/28/12 | FA | | | 1 |

| | | | | |
|----------|----|------|-------|----------|
| DATE | BY | CHKD | APP'D | REVISION |
| 10/28/12 | FA | | | 1 |

| | | | | |
|----------|----|------|-------|----------|
| DATE | BY | CHKD | APP'D | REVISION |
| 10/28/12 | FA | | | 1 |

1310 0720 54 01