

# 3010 Air Compressor Pump

## Operation & Maintenance Manual

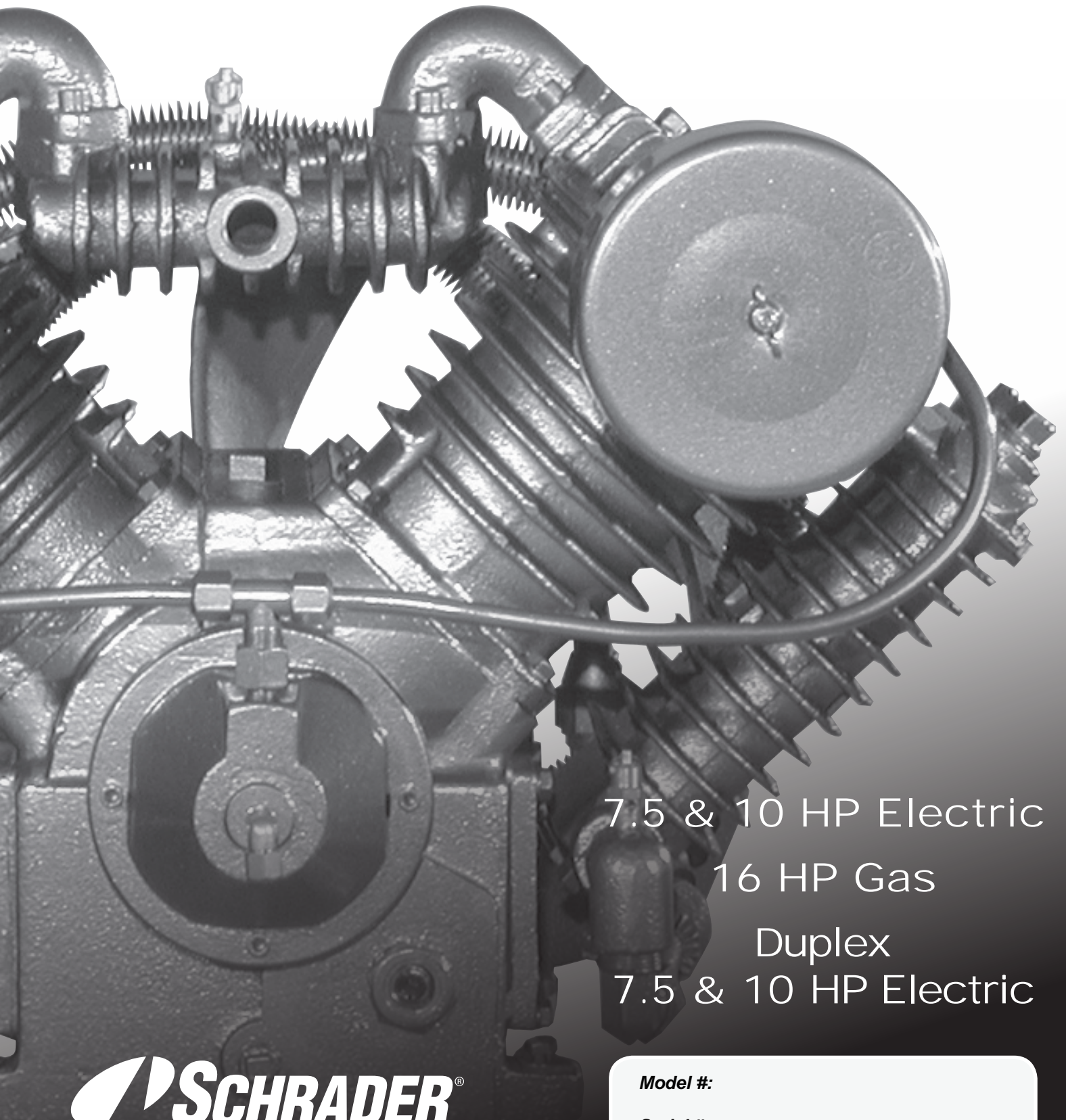

7.5 & 10 HP Electric  
16 HP Gas

Duplex  
7.5 & 10 HP Electric

**SCHRADER**<sup>®</sup>  
INTERNATIONAL

*Model #:*

*Serial #:*

## PERFORMANCE SPECIFICATIONS

Description	L X W X H	Phase	Voltage	Disp. CFM	SCFM	Pump Cyl.	Pump RPM
7.5 HP Electric Horizontal 80 Gallon Tank	65" X 25" X 46"	1	230	32.6	24	4	600
7.5 HP Electric Horizontal 120 Gallon Tank	71" X 24" X 50"	1	230	32.6	24	4	600
7.5 HP Electric Vertical 80 Gallon	41" X 24" X 73"	1	230	32.6	24	4	600
7.5 HP Electric Horizontal 80 Gallon Tank	65" X 25" X 46"	3	208/230/460	32.6	24	4	600
7.5 HP Electric Horizontal 120 Gallon Tank	71" X 24" X 50"	3	208/230/460	32.6	24	4	600
7.5 HP Electric Vertical 80 Gallon	41" X 24" X 73"	3	208/230/460	32.6	24	4	600
10 HP Electric Horizontal 80 Gallon Tank	65" X 25" X 46"	3	208/230/460	43.5	32	4	800
10 HP Electric Horizontal 120 Gallon Tank	71" X 24" X 45"	3	208/230/460	43.5	32	4	800
10 HP Electric Vertical 80 Gallon	39.5" X 24" X 73"	3	208/230/460	43.5	32	4	800
10 HP Electric Vertical 120 Gallon	39.5" X 28" X 73"	3	208/230/460	43.5	32	4	800
(2) 7.5 HP Electric Horizontal 120 Gallon	81" X 26.5" X 52"	1	230	65.3	48	4	600
(2) 7.5 HP Electric Horizontal 120 Gallon	81" X 26.5" X 52"	3	208/230/460	65.3	48	4	600
(2) 10 HP Electric Horizontal 120 Gallon	81" X 26.5" X 52"	3	208/230/460	87.1	64	4	800
(2) 10 HP Electric Horizontal 200 Gallon	81" X 26.5" X 52"	3	208/230/460	87.1	64	4	800
16 HP Briggs & Stratton Gas Horizontal 30 Gallon Tank	50" X 23.5" X 43"			41	32	4	800

## PUMP

Bore & Stroke	# Cyl.	Mounting Holes	Oil Capacity	Wt.	Max. Pressure
4 1/4" L, 2 1/8" H X 3 1/2"	2	9 5/8" X 7 3/4"	1 3/4 qts.	214 lbs.	200 PSI

## WARNING



**CAREFULLY READ THE INSTRUCTION MANUAL INCLUDED WITH THE PRODUCT BEFORE OPERATION.**



Air from this compressor will cause severe injury or death if used for breathing or food processing. Air used for these processes must meet O.S.H.A. 29 c.f.r. 1910.134 or f.d.a. 178.3570 regulations.



**RISK OF ELECTRICAL SHOCK** - Has live electrical parts when power is connected. To reduce the risk of electric shock, do not expose to rain, excessive humidity or running water. Store indoors. Must be grounded according to all National, State and Local electrical codes to avoid electrical shock.



**RISK OF INJURY** - Has moving parts. Do not direct air stream at body. Use eye protection. May start or stop automatically when power is connected. Should not be operated in places where there are children or pets.



**RISK OF FIRE OR EXPLOSION** "Must be installed and operated in well ventilated area that is free from flammable gases, excessive humidity or running water". Do not carry while painting. Use a minimum of 15 feet of hose when connecting the spray gun to the compressor. Do not spray combustible / flammable liquid in a confined area. Do not smoke while spraying or spray where spark or flame is present. Keep compressor at least 20 feet away from spraying area.



**RISK OF BURSTING** - If the air tank becomes defective due to mechanical or chemical problems it must be replaced. Never attempt to weld on or perform any other repair on the tank. Do not adjust regulator to result in output pressure greater than marked maximum pressure of tool attached. The tank is a pressure vessel and should be inspected on regular intervals by an accredited inspector.



Disconnect, tag and lock-out power source, then release all pressure from the compressor / tank before attempting to install, service, relocate or perform any maintenance. (O.S.H.A. Regulation 1910.147).



Do not use an extension cord with this compressor. Extension cords experience voltage drops and can result in damage to the electric motor.

## Contents

Page

Performance Specs.....	2
Safety Instructions.....	4
Mounting Stationary Air Compressor .....	5
Wiring Recommendations .....	6
Wiring Diagram.....	7
Troubleshooting .....	8
823010 Compressor Diagram .....	10
823010 Compressor Parts List.....	11
Cylinder Head Parts Diagram .....	12
Centrifugal Unloader/Electric Motor Maintenance.....	13
Electric Unit Diagram and Parts List .....	14
Gas Unit Diagram and Parts List .....	15
Unloader Adjustment .....	16
Duplex Unit Diagram and Parts List.....	17
Duplex Selective Switch Instructions .....	18
Duplex Wiring Diagram Single Phase.....	19
Duplex Wiring Diagram Three Phase.....	20
Duplex Wiring Diagram Three Phase 460 Volts.....	21
Maintenance Schedule - Check Chart .....	22
Maintenance Records .....	23
Refrigerated Dryers, Pressure Washers, and Nitrogen Generators .....	24
Battery Connections (Gas Engines).....	25
Warranty .....	26



**Avoid electric shock- Unit must be dry before connecting to electricity and during use.**



**Grounding and static conductivity - Ground unit as required by national and local electrical codes. Added grounding, static-conductive belts and other static-conductive controls may be needed in environments such as grain elevators and chemical plants- ask a qualified engineer.**



**Duplex Unit is powered by two motors from two separate electrical power sources. The motors start and stop automatically to maintain tank pressure. Electric motors are programmed to start with a delay. Avoid injury: disconnect, tag, and lock-out both electrical power sources and release air pressure from tank and air lines before attempting to install, relocate or perform any maintenance or repair.**



**READ THE COMPLETE OWNER'S MANUAL AND ALL LABELS ON THIS UNIT BEFORE INSTALLING OR USING.**

## SAFETY INSTRUCTIONS

When using air compressors and compressed air accessories, basic safety rules and precautions should always be followed including the following:

1. Read all instructions fully before operating this compressor.
2. Never use a compressor that is defective, operating abnormally, making strange noises, or otherwise appears defective. Stop using compressor immediately and arrange for repairs by an authorized service center.
3. Do not modify compressor. Always contact the authorized service center for any repairs.
4. Use only the manufacturer's replacement parts. Replacement parts not manufactured by Schrader Bridgeport may void your warranty and can lead to compressor malfunction and personal injuries. Replacement parts are available from the manufacturer.
5. Wiring, starters, breakers and other related electrical equipment should conform to electrical codes when operating any electric air compressors. Electrical connections should be made by a licensed electrician.
6. Always disconnect compressor from its power source and remove the compressed air from the tank before servicing, inspecting, cleaning, replacing, or checking any parts.
7. Do not operate compressor without belt guard. If maintenance or servicing requires the removal of a guard or safety feature, be sure to replace the guard or safety feature before resuming operation of the compressor.
8. Do not use gasoline compressor if Load Genie does not operate properly. Have defective Load Genie replaced by an authorized service center.
9. Avoid unintentional starting. Do not move the compressor while connected to its power source or when the air tank is filled with compressed air.
10. Turn off the compressor when not in use. Then open the drain cock to discharge the compressed air from the air tank.
11. Do not expose compressor to rain. The compressor should be stored in a dry clean environment.
12. Do not use compressor in the presence of flammable liquids or gases. Compressor can produce sparks during operation. Never use compressor in sites containing lacquer, paint, benzene, thinner, gasoline, gases, adhesive agents and other materials, which are combustible or explosive.
13. Use only recommended air handling parts acceptable for minimum pressure. Never use pressurized air accessories or parts in the air system that are not suitable for the maximum air pressure involved. The risk of bursting exists with use of unsuitable equipment. Always maintain maximum pressure specified by the manufacturer.
14. If your compressor is used for spraying, do not spray in vicinity of open flame or other sources of ignition. Always direct paint or sprayed material away from compressor and locate compressor to minimize over spray accumulation on compressor or sprayer parts.
15. Do not wipe plastic parts with solvent. Solvents such as gasoline, thinner, benzene, carbon tetrachloride and alcohol may damage and crack plastic parts. Wipe plastic parts with a soft cloth, lightly dampened with soapy water and dry thoroughly. When using cleaning solvent, follow the instructions provided by the solvent manufacturer.
16. Keep pressure relief devices free from paint or other accumulation. The motor air vent must be kept clean so that air can freely flow at all times. Check for dust build-up frequently.
17. Do not install Shutoff valves in the discharge line between the compressor and the receiver unless a safety valve, with adequate flow capacity and pressure setting, is located between shutoff valve and the compressor. Never operate a compressor without all guards or safety features in place and in proper working order.
18. Proper maintenance and care is necessary to ensure safe operation of air compressor. Check compressor according to the maintenance schedule provided in this manual. Maintain compressor with care. Follow instructions for lubrication. Keep all screws, bolts, and plates tightly mounted. Check for damaged parts and air leaks, daily. Check for alignment of moving parts, binding of moving parts, guard, breakage of parts, and any other conditions that may affect the operation of compressor. Drain tank daily to prevent rust formation and damage.
19. Do not operate any compressor with damaged wiring or hosing, or after the compressor or air handling parts have been dropped, damaged or show signs of deterioration, weakness or leakage. Do not use them if a deficiency is found. A unit that is damaged should be properly repaired or replaced by an authorized service center unless otherwise indicated elsewhere in this Instruction Manual.
20. Keep clear of compressor while operating. It may become extremely hot during operation. To reduce the risk of burns, do not touch tubes, heads, cylinders or motors.
21. Never touch moving parts. Always wear safety goggles or equivalent eye protection. Dress properly. Do not wear loose clothing or jewelry. These can be caught in moving parts. Wear protective hair covering to contain long hair.
22. Never aim compressed air at anyone or any part of the body.
23. Never operate a compressor in damp or wet location. Protect yourself against electric shock. Prevent body contact with grounded surfaces such as pipes, radiators, ranges and refrigeration enclosures.

## MOUNTING FOR STATIONARY AIR COMPRESSOR ONLY.

**Disconnect power and release air pressure before installing and/or performing maintenance.**

### UNPACKING INSTRUCTIONS

The two stage compressor was inspected at the factory and packaged to protect against shipping damage. When you unpack your unit, inspect for damaged or missing parts. If there are any damaged or missing parts, the transportation company's agent should make a notation to the effect on the Bill of Lading. Claims, should be settled directly with the transportation company.

All Vertical Compressors are top heavy and can easily tip over. Use appropriate lifting device for moving unit to desired location. When using air compressors and compressed air accessories, basic safety rules and precautions should always be followed. Read the compressor operating instruction before attempting to assemble, install, operate, or maintain the product. Failure to comply with the safety instructions could result in personal injury and/or property damage.

**The compressor must be placed in a clean and well ventilated room.** Compressor should be located at least 18-30 inches away from a wall or other obstruction that will impede air flow through the fan-bladed flywheel. Do not place compressor where heat is excessive. Provide adequate fresh air and exhaust ventilation from area in which the compressor is located. Place compressor on a firm, level floor. Remove wood shipping skid before installation. **Failure to remove from wooden skid will void all warranties.** Permanent installations should be bolted to the floor. Bolting holes are provided in the base feet. Shim compressor level before bolting down to floor. Avoid putting stress on your new compressor by using our Mounting Kit (824678).

### Stationary Air Compressor Mounting Kit For Electric Models only. Order 824678.

#### Stationary Air Compressor Mounting Instructions

1. Select a location for mounting unit on a firm and level floor.
2. Position unit and mark feet location in center hole of each foot.
3. Prepare to drill holes by removing unit.
4. Drill each of the marked holes 3" in depth using a 3/4" concrete drill bit. Blow out holes and insert lag shield making sure they are flush with the floor.
5. Position unit over drilled holes.
6. Place one rubber isolation pad under each foot.
7. Assemble 1 1/2" metal/rubber washer and lag bolt into each lag shield. Do not over tighten.

#### Flex Air Line Installation

1. Install 3/4" NPT nipple into tank outlet hole
2. Install 3/4" NPT Ball Valve.
3. Install 3/4" x 36" Flexible Hose.

Note: Teflon Tape should be used on all thread connections.

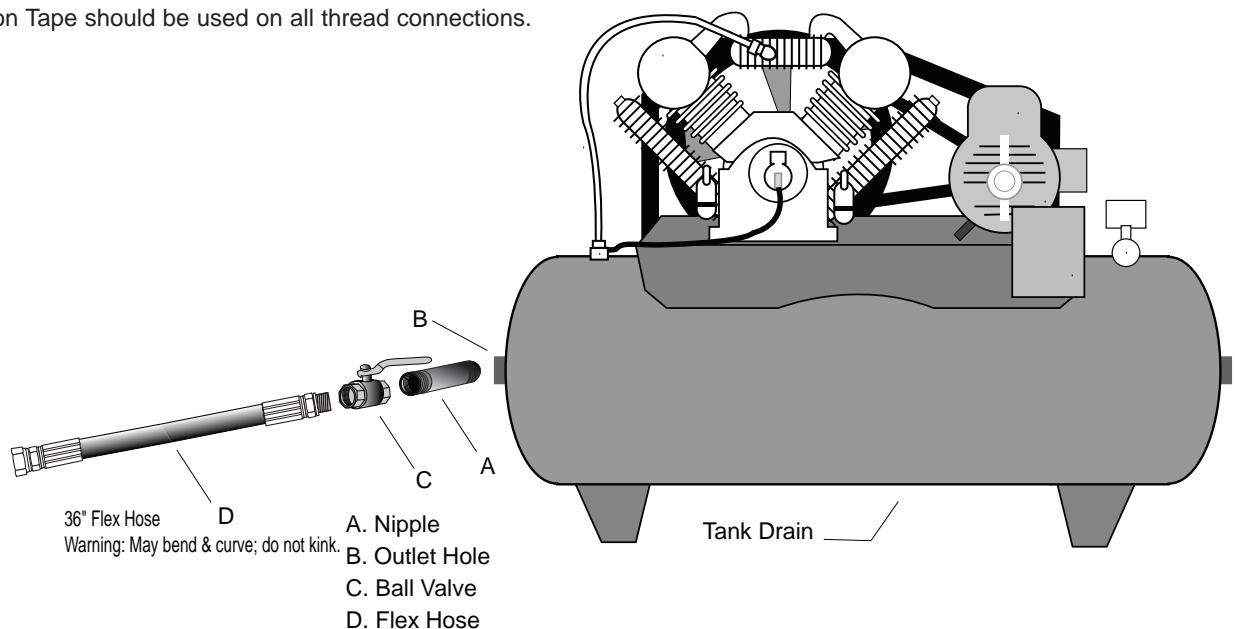
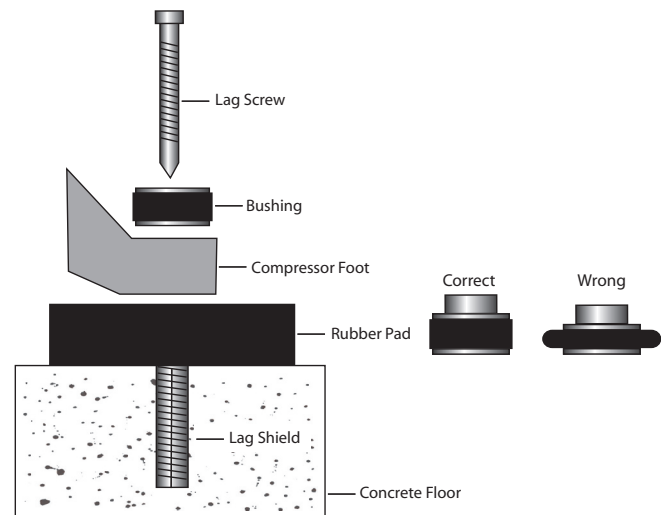

## DIRECTION OF ROTATION

As the compressor starts, check the rotation of the units. Standard rotation is clockwise, viewing the compressor from the side of the sight glass. A rotation arrow is placed on the flywheel at the factory. Should the rotation be incorrect, disengage the power and correct the motor wiring.

**Warning: After the compressor is started, it will operate automatically.**

When the air pressure in the receiver reaches the preset high pressure level the pressure switch opens, electrically stopping the compressor drive motor. As the air is used from the receiver the pressure drops allowing the pressure switch to close at the preset low pressure level, which restarts the driver motor. Meets ISO 100 viscosity requirements (high viscosity SAE 30W to low viscosity SAE40W). For ambient temperatures below 41°F use oil that meets ISO 68 viscosity requirements (high viscosity SAE 20W). For ambient temperatures above 77°F use oil that meets ISO 150 viscosity requirements (high viscosity SAE 40W).

## LUBRICATION

**Compressor may or may not be shipped with oil.**

Change oil after first **50 hours** (or two weeks) of operation. Afterwards, change petroleum-based oils every 1000 hours of operation.

Before operating, check the sight glass for oil level which should be at halfway. Add oil to crankcase if level is below halfway level. Do not over fill. This compressor requires a non-detergent, 30 wt. oil such as Manufacturer # 826020. Initial start up oil should be changed after first two weeks of operation.

**Do not overfill!**

Use a high quality, non-detergent petroleum-based compressor oil containing anti-oxidant and corrosion-inhibiting additives such as Manufacturer # 826020 to lubricate the compressor pump.

**Do not use detergent oils in the pump.**

If oil turns milky replace oil and move unit to less humid conditions.

For normal ambient temperatures between 41°F and 77°F use oil that meets ISO 100 viscosity requirements (high viscosity SAE 30W to low viscosity SAE40W). For ambient temperatures below 41°F use oil that meets ISO 68 viscosity requirements (high viscosity SAE 20W). For ambient temperatures above 77°F use oil that meets ISO 150 viscosity requirements (high viscosity SAE 40W).

Ambient Temp.	Viscosity @ 100°F SSU	ISO Viscosity CS +	SAE No.
0° - 40°	250-350	46-68	20
40° - 80°	450-550	100	30
80° - 120°	650-750	150	40
Under 0° - Over 120°	Consult Factory		

## WIRING RECOMMENDATIONS

Note: All wiring recommendations, performance, torque readings are listed for each separate pump. All wire sizes and breaker sizes are listed for each motor. Each motor must be separate with it's own breaker and wire and have it's own separate power source as listed in charts. Installation or modifications should be made by a Competent Electrician being sure that:

1. Magnetic starters with Thermal Overload are required for motor warranty and protection.
2. The power source is sufficient and service has adequate ampere rating. (See following chart).
3. The line wire is the proper size and that no other equipment is operated from the same line. The following chart gives minimum recommended wire sizes for compressor installations. For longer lines, call manufacturer.
4. The Duplex air compressor must have two separate power sources, each motor must be wired independently of the other, using the chart below.

Various national and local codes and standards have been set up covering electrical apparatus and wiring. These should be consulted and local ordinances observed. Our recommended wire sizes may be larger than the minimum set up by local ordinances to prevent excessive line voltage drop.

5. Failure to comply with all wiring instructions, including breaker sizes, wire sizes, and recommended wire length will void all warranties on electrical parts.

<b>WARNING</b>					
<b>Wire Size (Rubber Covered)</b>					
HP	Wire Length	Single Phase & DC		Three Phase	
		208 V	230 V	230 V	460V
5	50' or less	8	8	10	14
7.5	50' or less	6	6	10	14
10	50' or less			8	14
15	50' or less			6	10
20	50' or less			4	10
25	50' or less			3	8
30	50' or less			2	8
<b>Breaker Size</b>					
		Single Phase		Three Phase	
		208 V	230 V	230 V	460V
5		60	60	30	15
7.5		80	80	45	20
10				60	25
15				80	40
20				120	60
25				150	75
30				180	90

**Increase wire size up to next size for each additional 50' feet.**

## WIRING DIAGRAM

1. Rewire motor per data plate on motor or instruction sheet.
2. Check pressure switch electric rating and replace if necessary.
3. Check electric rating of thermal over load switch or magnetic starter and replace complete switch or thermal overload elements as required.

**Incoming Power to be wired to Mag Starter only!**

L1, L2, L3 indicates supply line terminals.  
T1, T2, T3 indicates load terminals.

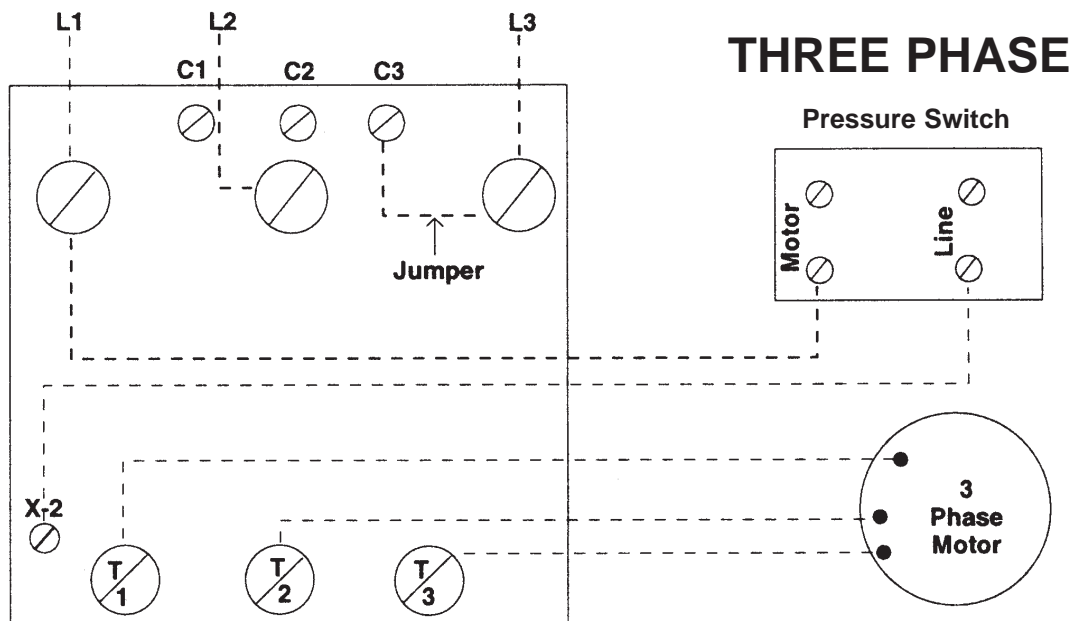
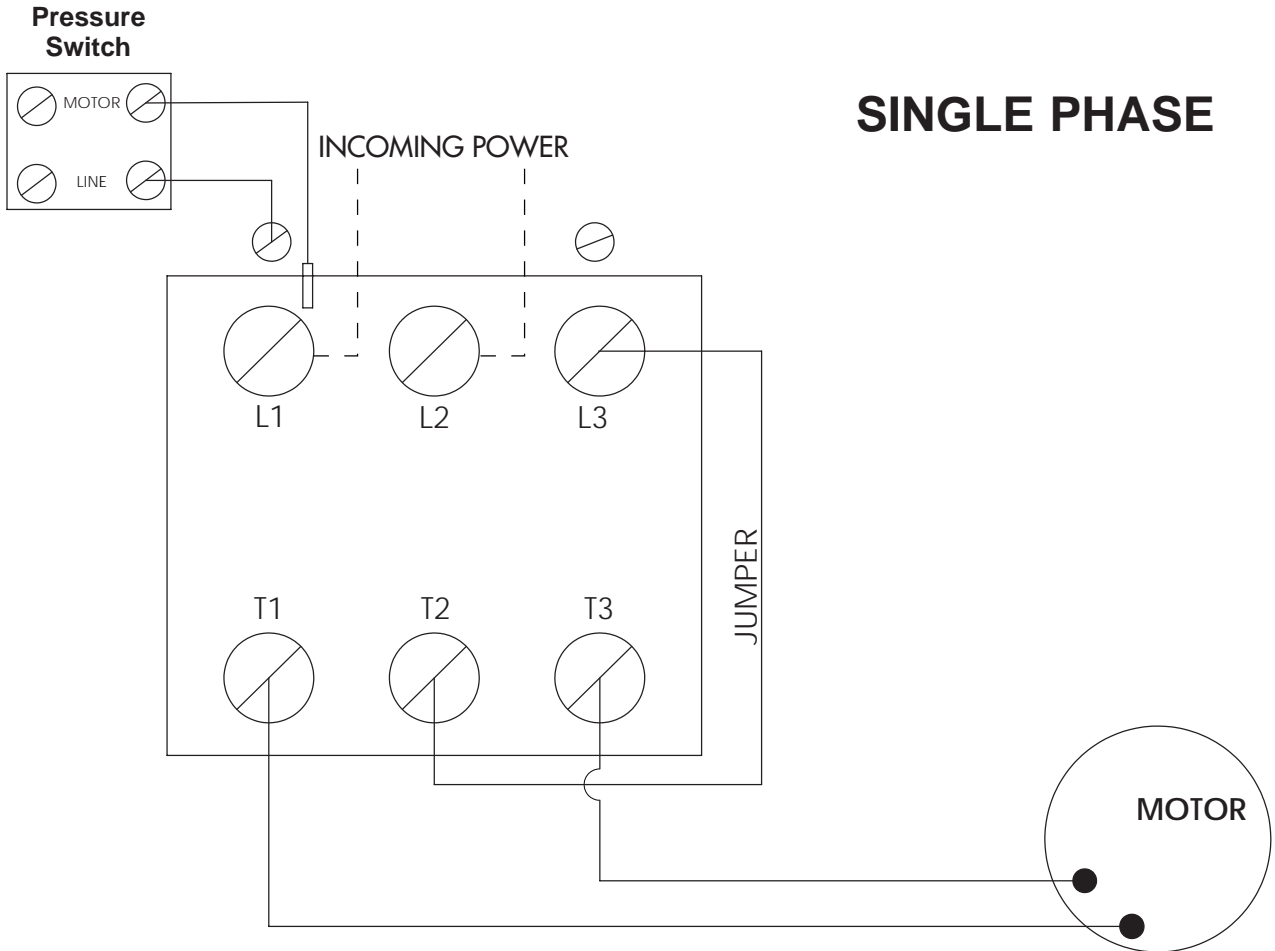

## TROUBLESHOOTING

PROBLEM	POSSIBLE CAUSE	CORRECTIVE ACTION
1. Compressor will not operate.	1. No electrical power.	1. No electrical power.
	2. Pressure switch not making contact	2. See pressure switch adjustment.
2. Excessive noise in operation	1. Loose pulley, flywheel, belt, belt guard	1. Tighten.
	2. Lack of oil in crankcase.	2. Check for possible damage to bearings, replenish oil.
	3. Piston hitting the valve plate.	3. Remove the compressor cylinder head and inspect for foreign matter on top of the piston. Add a new gasket and reassemble the head.
	4. Compressor floor mounting loose.	4. Tighten.
	5. Defective crankcase.	5. Repair or replace.
	6. Excessive crankshaft end play.	6. Adjust and shim properly.
3. Knock - same cycle as R.P.M.	1. Main bearings.	1. Replace bearings.
	2. Connecting rod bearing.	2. Tighten.
4. Knock occurs while compressor is loading.	1. Connecting rod bearings.	1. Replace rod.
	2. Wrist pins, wrist pin bearings.	2. Replace complete piston assembly
5. Excessive oil consumption.	1. Restricted air intake.	1. Clean or replace air filter.
	2. Oil leaks.	2. Tighten bolts or replace gasket.
	3. Worn piston rings.	3. Replace piston rings.
	4. Wrong oil viscosity.	4. Drain oil, refill with oil of proper viscosity. <b>See Lubrication Section.</b>
	5. Compressor tilted too much.	5. Level compressor.
	6. Scored cylinder	6. Replace cylinder.
6. Oil in discharge air.	1. Compressor air intake restricted.	1. Clean air filter element and check for other restrictions in the intake system.
	2. Worn piston rings.	2. Replace rings.
	3. Excessive oil in compressor.	3. Drain down to full mark on sight gauge.
	4. Wrong oil viscosity.	4. Check viscosity. <b>See Lubrication Section.</b>
	5. Piston rings installed up-side down.	5. Install ring in proper position.
7. Compressor vibrates.	1. Mounting bolts loose.	1. Tighten.
	2. Compressor not properly mounted	2. Level compressor so that all feet touch the floor before tightening down.
	3. Pulley and flywheel misaligned.	3. Realign.
	4. Belts loose.	4. Tighten belts. See Maintenance Section.
	5. Bent crankshaft.	5. Replace crankshaft.



PROBLEM	POSSIBLE CAUSE	CORRECTIVE ACTION
8. Air blowing out of inlet	1. Broken first stage inlet valve.	1. Replace valve assembly.
9. Insufficient pressure at point of use.	1. Leaks or restriction.	1. Check for leaks or restriction or piping. Repair.
	2. Restricted air intake.	2. Clean or replace air filter element.
	3. Slipping belts	3. Tighten belts. See maintenance section.
	4. Service hose too small.	4. Replace with larger hose
	5. Excessive air requirement.	5. Limit air requirement to compressor capacity.
10. Receiver does not hold pressure when compressor is unloaded	1. Faulty check valve.	1. Bleed tank! Disassemble check valve assembly, clean or Replace faulty parts. <b><i>Danger</i></b> Do not disassemble the check valve with air in tank. Note: check valve is always the first valve in the line from the compressor to the compressor.
11. Excessive belt wear.	1. Pulley out of alignment.	1. Realign motor pulley with compressor flywheel.
	2. Belts too tight.	2. Adjust tension.
	3. Belts too loose.	3. Adjust tension. See maintenance section.
	4. Pulley or flywheel wobble.	4. Check for worn crankshaft, keyway or pulley bore, resulting from running with a loose pulley.
	5. Nick in belt groove of pulley or flywheel.	5. File smooth.
12. Excessive discharge air temperature.	1. Dirty cooling surfaces.	1. Clean cooling surfaces of cylinder, intercooler and discharge tube.
	2. Poor ventilation.	2. Improve ventilation or relocate compressor. See install instructions.
	3. Blown head gasket.	3. Replace head gasket.
	4. Restricted air intake	4. Clean or replace air filter element.
	5. Worn valves.	5. Repair or replace valves.
13. Receiver pressure builds up slowly.	1. Dirty air filter.	1. Clean or replace filter element.
	2. Blown cylinder head gasket.	2. Install new gasket.
	3. Worn or broken low pressure intake or discharge valves.	3. Install new head gasket.
	4. Air leaks.	4. Tighten joints.
	5. Loose belts.	5. Tighten belts. See maintenance section.
	6. Speed too slow.	6. Check speed.

# 823010 COMPRESSOR PUMP

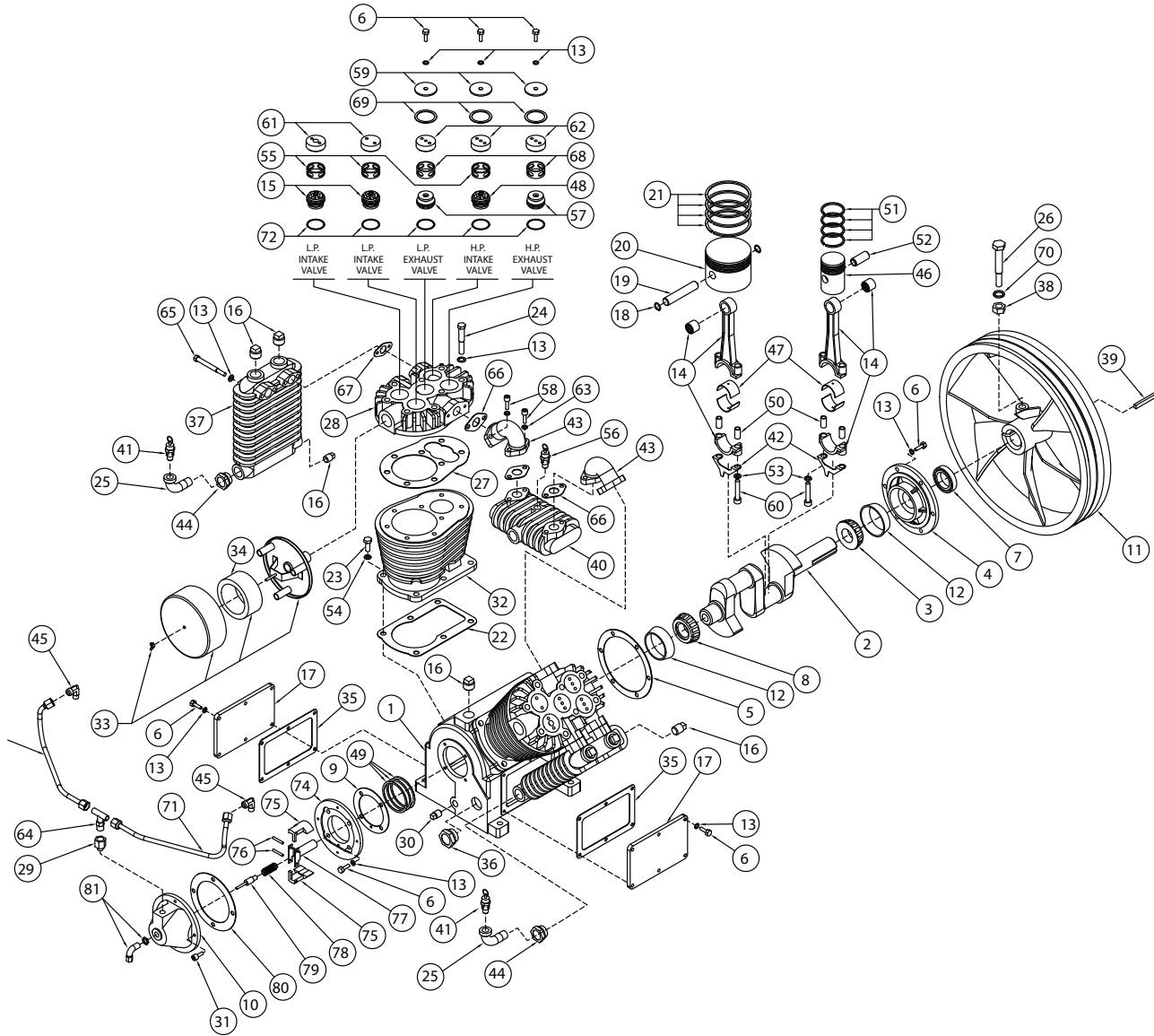

Recommended Torque Readings	Foot pounds
Head Bolts	50-55
Valve Retainer	80-90
Rod Bolts	30
Crankcase Bolts	30-40
Side Cover Bolts	30-40
Front and Rear Cover Bolts	30-40
Manifold Bolts	30-40
Flywheel Bolts	65-70
Intercooler Bolts	30-40

## 823010 TWO-STAGE 4 PISTON COMPRESSOR PUMP

Item	Part	Description	QTY
1	82708001	Crankcase	1
2	82709001	Crankshaft	1
3	82050158	Bearing Front	1
4	82701000	Cap Front Bearing	1
5	82070163	Gasket Front Cap	1
6	*G.H	Cap screw Hex M8X20	18
7	82060068	Seal - Shaft	1
8	82050159	Bearing Rear	1
9	82070172	Gasket Rear Cap	1
10	82728004	Centrifugal Unloader Adapter Plate	1
11	82713000	Flywheel 19"	1
12	See 3 & 8	Bearing - Cap	2
13	82070201	Gasket Copper	24
14	82705107	Rod Connecting Steel w/ Needle Bearing	4
15	82727000	Valve Assembly - LP Inlet	4
16	*G.H	Pipe plug	7
17	82020147	Cover Crankcase Side	2
18	82200100	Snap ring - Internal	8
19	82729000	Wrist pin - LP Piston	2
20	82720000	Piston LP 105mm	2
21	82719064	Piston Ring Set LP	2
22	82070162	Gasket Cylinder To Crankcase	2
23	*G.H.	Cap screw Hex M10X25	12
24	*G.H.	Cap screw Hex M12X70	16
25	82728002	Holder Unloader	1
26	*G.H.	Cap screw Hex M16X80	1
27	82070161	Gasket Cylinder Head	2
28	82710000	Head Cylinder	1
29	82703011	Breather	1
30	*G.H	Oil Drain Plug 3/8" NPT	1
31	*G.H.	Cap screw Skt HD M6X20	4
32	82711000	Cylinder	1
33	8232574	Filter Inlet Assembly	2
34	822580	Filter Inlet Element	2
35	82070165	Gasket Side Cover	2
36	82288700	Oil Level Sight Glass (Copper)	1
37	82706000	Intercooler	1
38	*G.H.	Nut Hex - M16	1
39	82080029	Key Flywheel	1
40	82706003	Aftercooler	1
41	82947	Valve Safety 60 PSI ASME	2
42	82705003	Dipper Oil	4

Item	Part	Description	QTY
43	82706001	Elbow Aftercooler	2
44	82703015	Elbow Copper	2
45	82727136	Elbow Intercooler	2
46	82720002	Piston - HP	2
47	82050122	Insert Rod - Bearing	4
48	82727001	Valve Assembly - HP Inlet	2
49	82090095	Shim .015 Brg Adjustment	1
49	82090094	Shim .010 Brg Adjustment	1
49	82090093	Shim .005 Brg Adjustment	1
50	82100101	Dowel Alignment	8
51	82719088	Set HP Piston Rings	2
52	82729006	Wristpin HP Piston	2
53	*G.H	Lockwasher 10	8
54	82070203	Gasket Copper	12
55	82727003	Spacer Inlet Valve	6
56	82951	Valve Safety 200 PSI ASME	1
57	82727002	Valve Assy HP/LP Discharge	4
58	*G.H.	Capscrew SKT Head M8X25	8
59	82727136	Cover Valve	6
60	*G.H	Capscrew SKT Head M10X45	8
61	82727134	Retainer Inlet Valve	6
62	82727135	Retainer Discharge Valve	4
63	*G.H	Lockwasher 8	8
64	82718017	T-Fitting Copper	2
65	*G.H.	Capscrew Hex M8X85	8
66	82070167	Gasket Aftercooler	4
67	82070169	Gasket Intercooler	4
68	82727004	Spacer Discharge Valve	4
69	82070170	Gasket Valve Cover	6
70	*G.H	Lockwasher 16	1
71	82703013	Breather Tube	2
72	82070202	Copper Valve Seat Gasket	10
73	826155-S	Elbow Valve & Unloader	1
74	82701029	Cap Rear	1
75	82100100	Pin - Hinge	2
76	82728000	Weight Unloader	1
77	82723003	Spring Unloader	1
78	82728003	Plunge Unloader	1
79	82070166	Gasket Unloader Cover	1
80	82120058	Nut Adjustment Lock	1
81	82160002	Bushing Reducing	2
n/a	82720123	Complete Plunger Assembly (for unloader)	1

\*Notes:

\*G.H. General Hardware

820185 - Gasket set includes: complete set of gaskets for pump.

820707 - Overhaul kit includes: Gasket set, ring set and valve assemblies for pump and two air filters

820182 - Valve & Head Overhaul Kit includes gaskets for pump head, two air filters and valve assemblies.

# CYLINDER HEAD

Order # 82288787 Spanner Tool,  
to remove Valves.

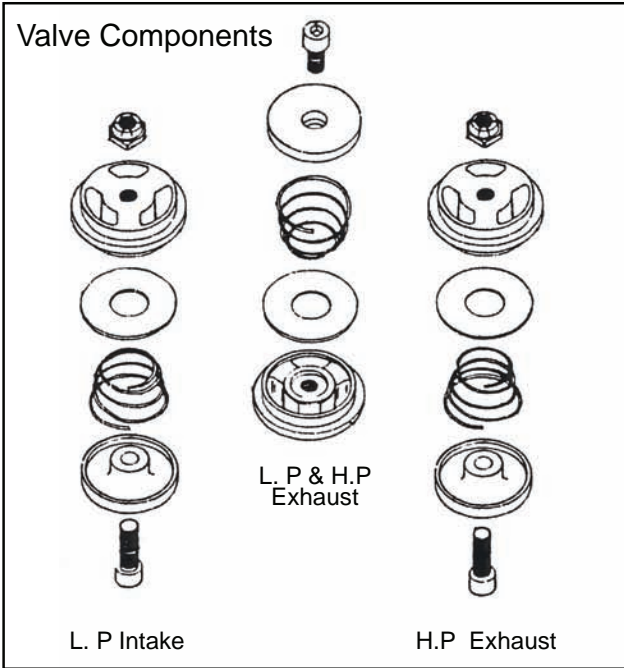

## Air Compressor Cylinder Head Parts Breakdown

Torque: Foot Lbs.  
Headbolts: 55  
Valve Retainer: 80

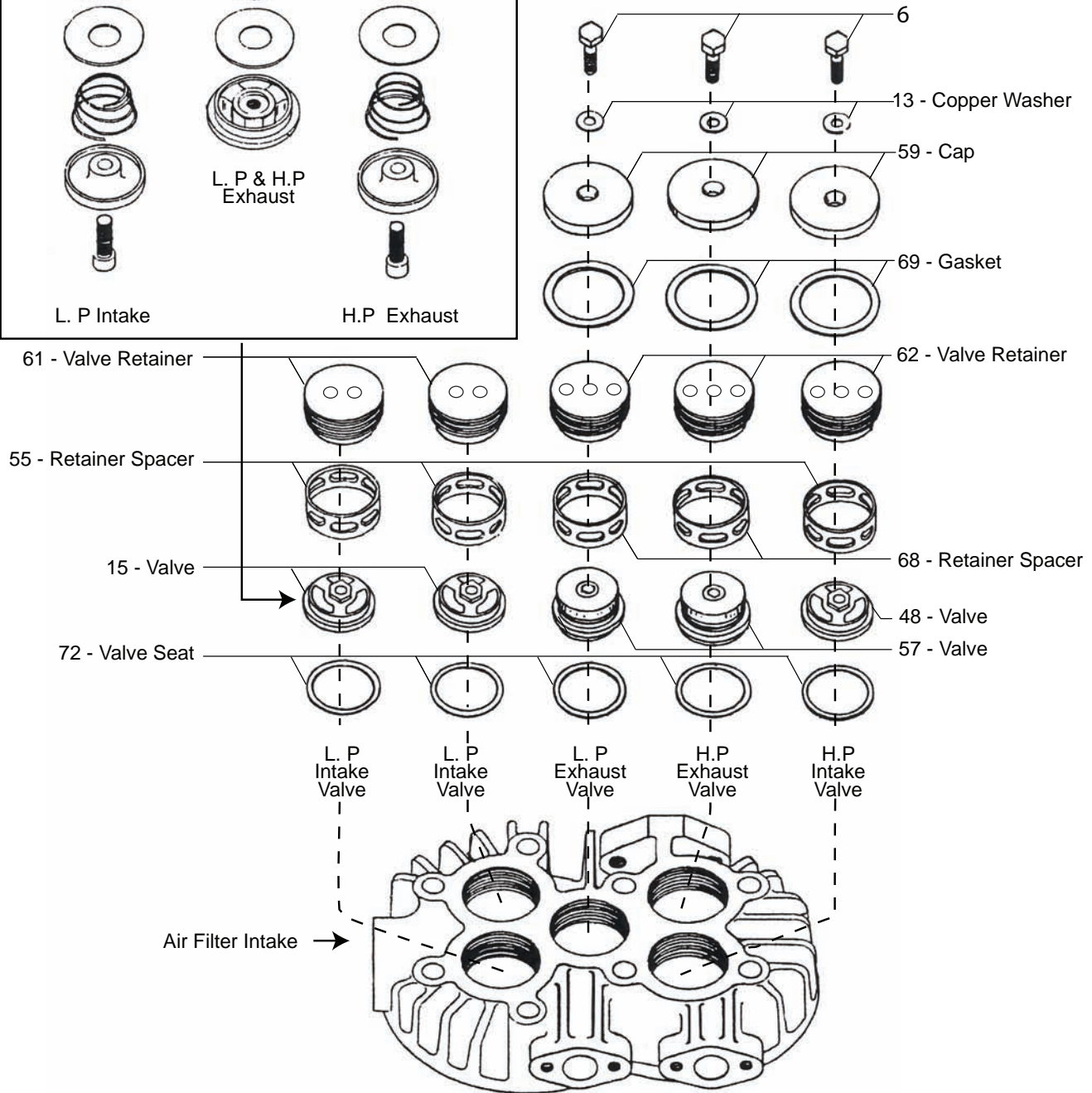

## CENTRIFUGAL UNLOADER

Ill. #	Description	Part No.
10	Cap - Rear	82701029
97	Holder - Unloader	82728002
98	Weight - Unloader	82728000
100	Pin - Hinge	82100100
103	Spring - Unloader	82723003
107	Plunger - Unloader	82728003
96	Cover - Centrifugal Unloader	82728004
105	Gasket - Unloader Cover	82070166
102	Capscrew - Skt Hd M6x20	G.H.
99	Elbow - Valve & Unloader	826155-S

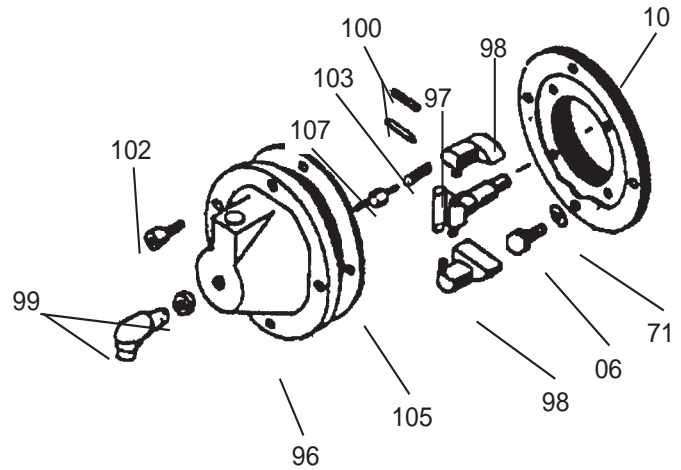

## MAINTENANCE & TROUBLE SHOOTING FOR ELECTRIC MOTOR

**Warning: Disconnect power before servicing Electric Motor.**

### General Inspection

Inspect the motor at regular intervals, approximately every 500 hours of operation or every 3 months, whichever occurs first. Keep the motor clean and the ventilation openings clear. The following steps should be performed at each inspection:

1. Check that the motor is clean. Check that the interior and exterior of the motor is free of dirt, oil, grease, water, etc. Oily vapor, paper pulp, textile lint, etc. can accumulate and block motor ventilation. If the motor is not properly ventilated, overheating can occur and cause motor failure.
2. Use a "Megger" periodically to insure that the integrity of the winding insulation has been maintained. Record the Megger readings. Immediately investigate any significant drop in insulation resistance.
3. Check all electrical connectors to be sure that they are tight.

### Lubrication & Bearings

Bearing Grease will lose its lubricating ability over time, not suddenly. The lubricating ability of grease (over time) depends primarily on the type of grease, the size of the bearing, the speed at which the bearing operates and the severity of the operating conditions. Good results can be obtained if the following recommendations are used in your maintenance program.

### Type of Grease:

A high grade ball or roller bearing grease should be used. Recommended grease for standard service conditions is Polyrex EM (Exxon Mobile). Equivalent and compatible greases include: Texaco Polystar, Rykon Premium #2, Pennzoil Pen 2 Lube, and Chevron SRI.

### Lubrication Intervals:

Recommended lubrication intervals are approximately every 9500 hours.

### Lubrication Procedure:

Be sure that the grease you are adding to the motor is compatible with the grease already in the motor. Consult your Baldor distributor or an authorized service center if a grease other than the recommended type is used.

### With Grease Outlet Plug.

1. Clean all grease fittings.
2. Remove grease outlet plug.
3. If the motor is stopped, add the recommended amount of grease. If motor is to be greased while running, a slightly greater quantity of grease will have to be added. Add grease slowly until new grease appears at shaft hole in the endplate or purge outlet plug.
4. Re-install grease outlet plug.

### Without Grease Outlet Plug.

1. Disassemble motor.
2. Add recommended amount of grease to bearing and bearing cavity. (Bearing should be about 1/3 full of grease and outboard bearing cavity should be about 1/2 full of grease). Note: bearing is 1/3 full when only one side of bearing is completely full of grease).
3. Assemble motor.

### Lubrication Amounts

<b>Weight of Grease to be added:</b>	0.61 Ounces	17 Grams
<b>Volume of Grease to be added:</b>	1.2 Cubic in.	3.9 Teaspoon

## ELECTRIC AIR COMPRESSOR

ILL. #	Description	Single Phase Horizontal	Three Phase Horizontal	Single Phase Vertical	Three Phase Vertical
1	Pump	3010	3010	3010	3010
2	Electric Motor 7.5 HP	827500MA	827500MB	827500MA	827500MB
2	Electric Motor 10 HP		821000MB		821000MB
3	Magnetic Starter 230 Volt	8215PW	823710PW	8215PW	823710PW
3	Magnetic Starter 460 Volt		823710PW460		823710PW460
4	Tank 80 Gallon	8282	8282	8281	8281
4	Tank 120 Gallon	8283	8283		82288673
5	Motor Pulley 7.5 HP	823806	82306	82306	82306
5	Motor Pulley 10 HP	823764	823764		
6	Check Valve	82C7510	82C7510	82P7510	82P7510
7	Belt Guard & Belt Guard Pan	82660	82660	82660	82660
	Belt Guard Brace	82661	82661	82661	82661
8	Belts 7.5 HP	82890	82890	82890	82890
8	Belts 10 HP	82826	82826	82826	82826
9	Tank Drain	82650	82650	82650	82650
10	Pressure Gauge	82513	82513	82516	82516
11	Pressure Switch 140/175	82775	82775	82775	82775
12	Bleeder Tube	82600	82600	82600	82600
13	Discharge Tube	82603 & AC Model#	82603 & AC Model #	82603H & AC Model #	82603H & AC Model #
14	3/4" Brass Adaptor	82623	82623	82623	82623
15	Safety Valve 200 PSI	82951	82951	82951	82951
16	3/4 Street Elbow	82654	82654	82654	82654
17	Air Filter Assembly 1" Intake	8232574	8232574	8232574	8232574

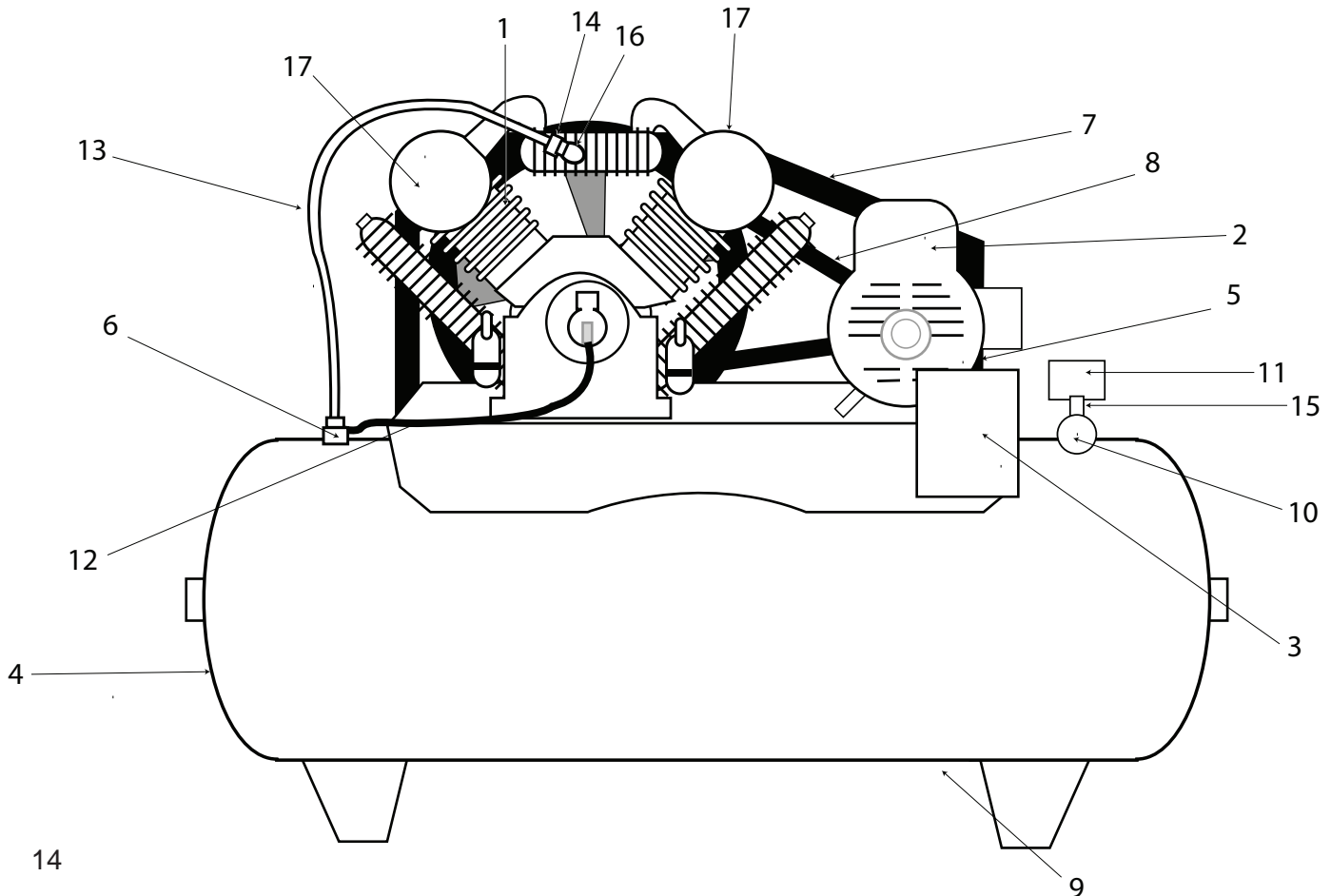

# GAS AIR COMPRESSOR

ILL.#	Description	Part Number
1	Pump	823010
2	Briggs Gas Engine	82847V
3	Engine Pulley	823804
4	Tank	8279
5	Check Valve unloader	82709
6	Belt Guard & Belt Guard Pan	82660R
7	Belts	82827
8	Tank Drain	82650
9	Pressure Gauge	82516
10	Bleeder Tube	82600
11	Discharge Tube	82603H & Model Number
12	3/4" Brass Adaptor	82623
13	Safety Valve 200 PSI	82951
14	3/4" Street Elbow	82654
15	1/2" X 3/4" Brass Elbow	82595
16	Throttle Cable	82205BNK
17	1/4" Tee	82652
18	1/2" Street Elbow	82672
19	Air Filter Assembly 1" NPT Intake	8232574
20	Belt Guard Bracket	82661
	Replacement Air Filter Element	822580

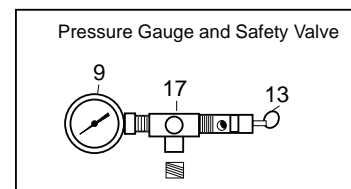
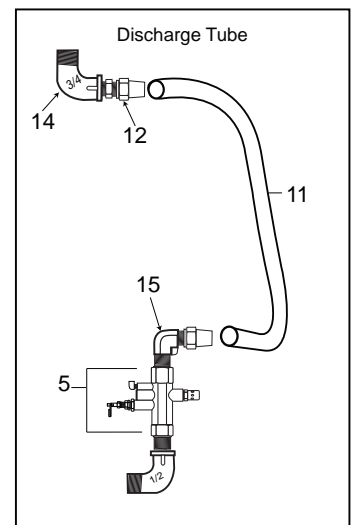
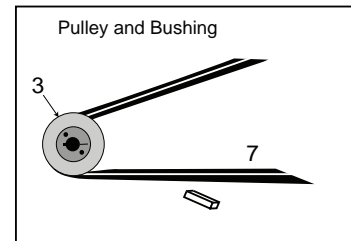
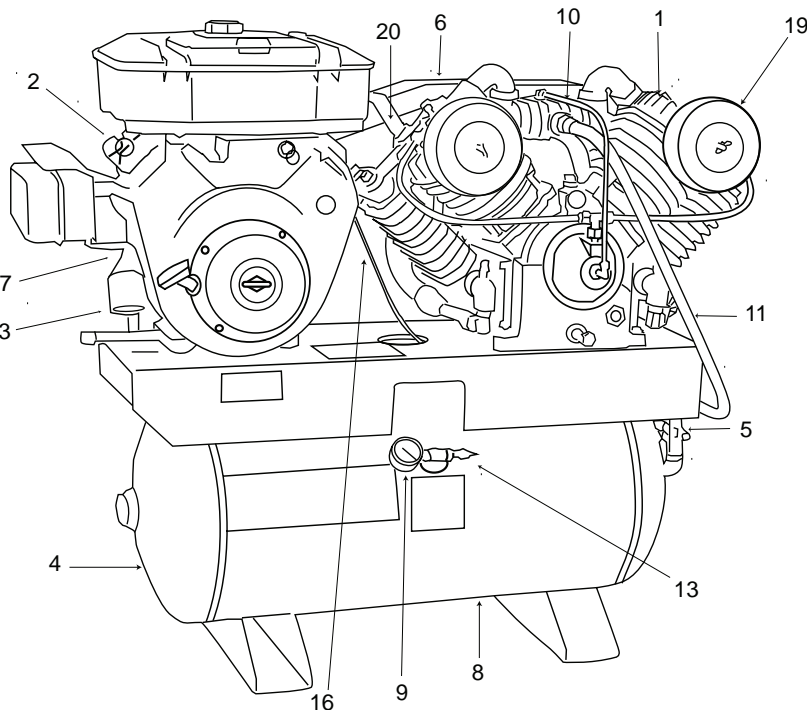

# UNLOADER ADJUSTMENT

Load Genie 82709

## Installation

The Load Genie has 1/2 NPT "IN" and "OUT" ports and is suitable for compressors with a discharge of up to 32 SCFM . The Load Genie is typically installed onto the tank with a short pipe nipple. The "OUT" port must be connected directly to the tank with no other check valves in between the tank and the Load Genie.

### Note:

On some retrofit applications, there may have been a type of check valve known as an "In Tank" check valve previously installed. Make sure there is a clear air path between the tanks and "OUT" port before installing the Load Genie. The compressor discharge line can now be routed into the "IN" port of the Load Genie.

The installation is now complete.

## Regulator Adjustment

Cutout pressure is adjustable from 60 PSI to 175 PSI with the standard silver spring. The differential (difference between cut-out and cut-in pressures) is typically set at the factory at approximately 15% of the cut-out pressure. This is usually a suitable differential and will not normally need to be readjusted.

1. Loosen range screw jam nut first.
2. Turn range screw clockwise to raise cut-out and cut-in pressure levels and counter clockwise to decrease cut-out and cut-in levels.
3. Start compressor and note cut-out and cut-in pressures. Make adjustments as necessary using range adjustment screw, when acceptable, tighten range adjustment screw jam nut.
4. Adjust the cut-in pressure to the desired level per steps #1, #2, and #3, as shown.
5. Loosen differential screw jam nut and turn differential screw clockwise to raise cut-out pressure and counter clockwise to decrease the cut-out pressure. Tighten differential screw jam nut when desired cut-out pressure is set. Since step 5 should not change the desired cut-in pressure set in step # 4, adjustment is now complete.

## Use with Gasoline Engine Throttle Controls

A 1/8 NPT tapped port in the end of the Load Genie allows the use of a throttle control to slow down the driving engine when in the cutout (venting) mode. The throttle control is simply a small (e.g., 1/2" dia. X 1" stroke) single-acting, spring return air cylinder which moves the throttle lever on the engine to the idle position when the cylinder is pressurized while in the cut-out mode.

Throttle control is specifically designed for this application. It is important that the throttle control air cylinder is leak-tight and that all connections between that Load Genie and the air cylinder are leak-tight.

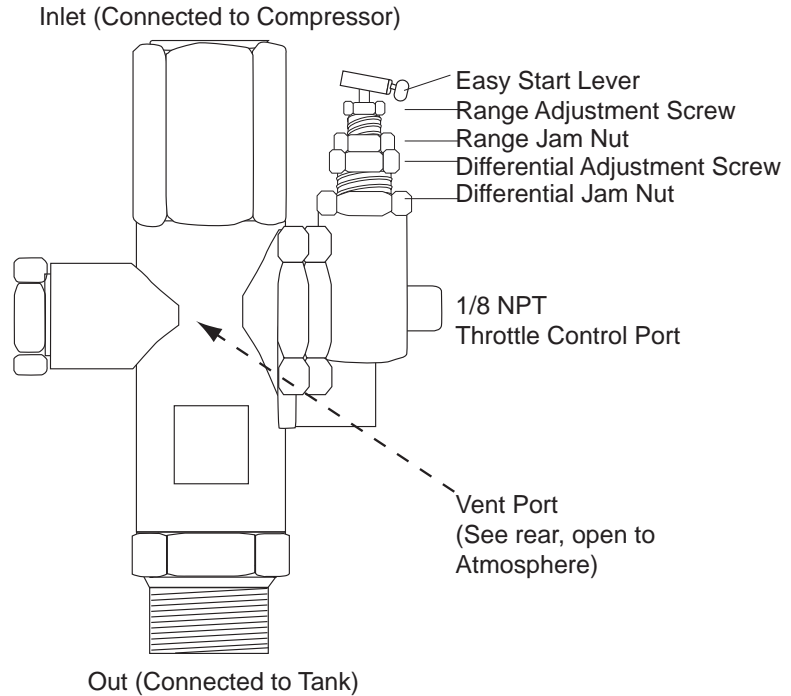

Loadgenie3 112807.ai

## Starting Unit

Easy Start: Place Easy Start Lever in upright position, Start Unit, when running smoothly flip lever to run position.

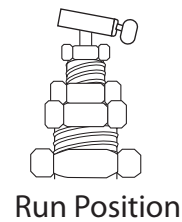
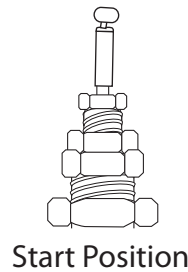



## DUPLEX ELECTRIC AIR COMPRESSOR

ILL.#	Description	Single Phase	Three Phase	460 Three Phase
1	Pump	823010	823010	823010
2	Electric Motor 7.5 HP	827500MA	827500MB	827500MB
2	Electric Motor 10 HP		821000MB	821000MB
3	Controller	82289051	82289710	82289050
4	Tank 120 Gallon	82289048	82289048	82289048
4	Tank 200 Gallon		82289049	82289049
5	Motor Pulley 7.5 HP	823806	823806	823806
5	Motor Pulley 10 HP		823764	823764
6	Check Valve	82P7510	82P7510	82P7510
7	Belt Guard & Belt Guard Pan	82660R	82660R	82660R
8	Belt Guard & Belt Guard Pan	82660	82660	82660
9	Belts 7.5 HP	82890	82890	82890
9	Belts 10 HP		82826	82826
10	Tank Drain	82650	82650	82650
11	Pressure Gauge	82516	82516	82516
12	Pressure Switch 140 / 175	82775	82775	82775
13	Pressure Switch 130 / 165 (need to adjust)	82775	82775	82775
14	Bleeder Tube	82600	82600	82600
15	Discharge Tube Left	82603H & Model Number + left	82603H & Model Number + left	82603H & Model Number + left
15	Discharge Tube Right	82603H & Model Number + right	82603H & Model Number + right	82603H & Model Number + right
16	Safety Valve 200 PSI	82951	82951	82951
17	Air Filter Assembly 1" NPT Intake	8232574	8232574	8232574

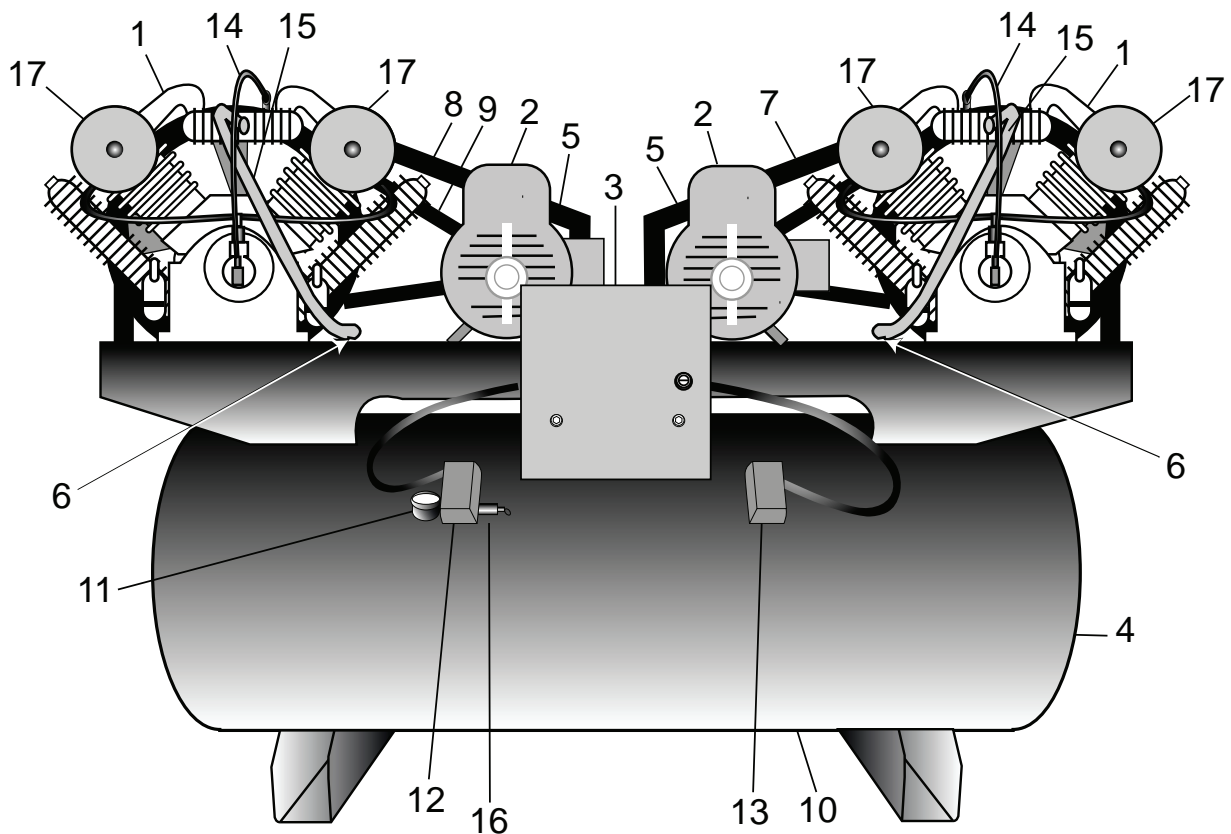

## DUPLEX UNITS ONLY

### Selective Selective Switch Instructions.

The Duplex control panel controls the operation of two compressor motors by sharing the load between the two motors. The panel contains 2 contactors with re-settable motor-overload protective devices, and a Siemens LOGO™ logic device. Motor-A & Motor-B are supplied separate input power sources. The power is connected to each of the contactors. The LOGO device and the control circuits take power from the Motor-A source.

### Operation

When power is applied to the Motor-A and/or Motor-B contactors, the panel is “hot”. That is, the pressure switch wires and motor output leads may be “hot”.

#### **Selector-Switch in LEFT position (Motor-A)**

Motor-A operates when the 175-psi switch is made. The 135-psi switch is not used. Motor-B doesn't operate.

#### **Selector-Switch in RIGHT position (Motor-B)**

Motor-B operates when the 175-psi switch is made. The 135-psi sensor is not used. Motor-A doesn't operate.

#### **Selector-Switch in CENTER position (Auto)**

This position is for automatic operation. One motor operates with a 15 second delay when the 175-psi switch is made while the 135-psi switch does not. If the 175-psi switch is made for more than 5 minutes, the second motor is started. If both the 175-psi and 135-psi switches are made, then both motors start with a 15 second delay between starting of motors. Once air pressure is satisfied and both motors stop, the motor that didn't run last will start next. That is, when the 175-psi switch is made, the motor which had started second the last time is started first the next time.

**WARNING**

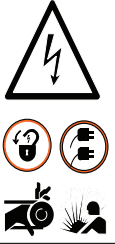

Duplex Unit is powered by two motors from two separate electrical power sources. The motors start and stop automatically to maintain tank pressure. Electric motors are programmed to start with a delay. Avoid injury: disconnect, tag, and lock-out both electrical power sources and release air pressure from tank and air lines before attempting to install, relocate or perform any maintenance or repair.

### Troubleshooting

1. Check that Motor inputs terminals are wired securely and are powered.
2. Check the motor connections are complete and secure.
3. Check pressure switch connections.
4. Check two control power fuses mounted in terminal blocks.
5. Check motor overloads – may need resetting.
6. Check LOGO controller light : OFF=no power, RED = powered but faulted, GREEN= powered and running OK.

See wiring diagram.

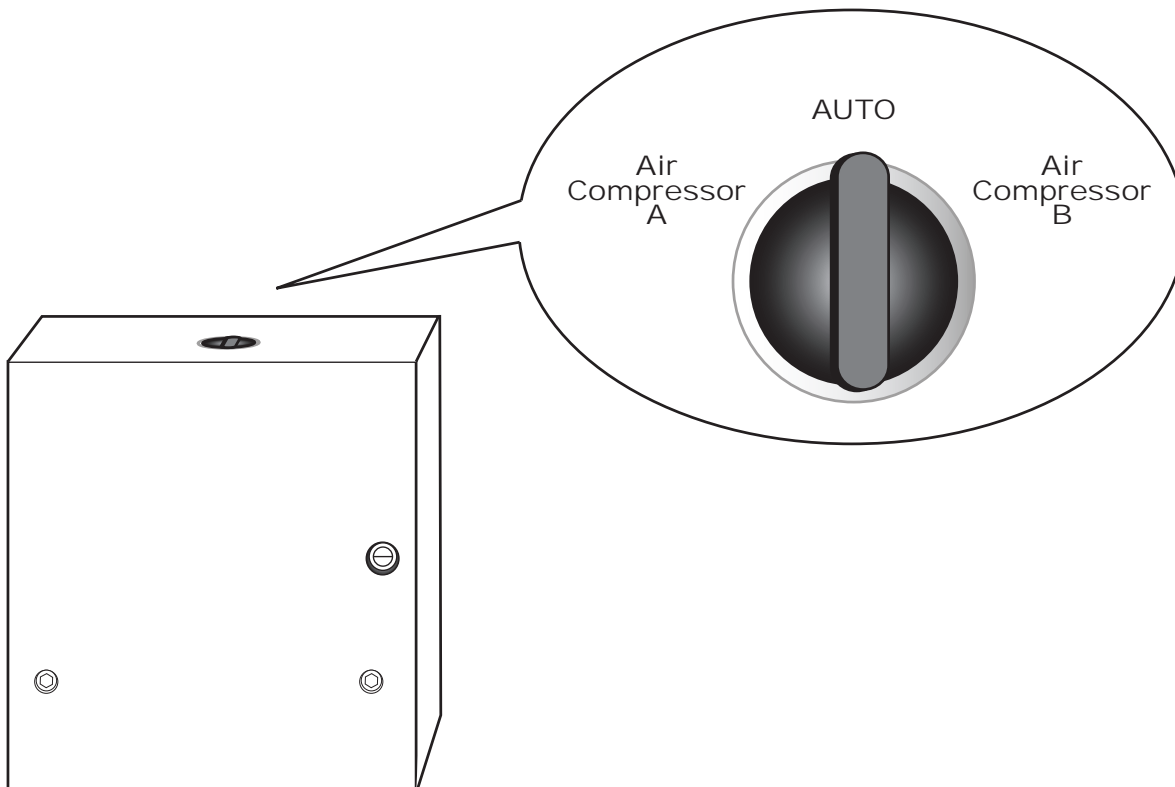

**DUPLEX UNITS ONLY** Wiring Diagram for 82289051  
 Single Phase 208/230 Volt Controller / Magnetic Starters

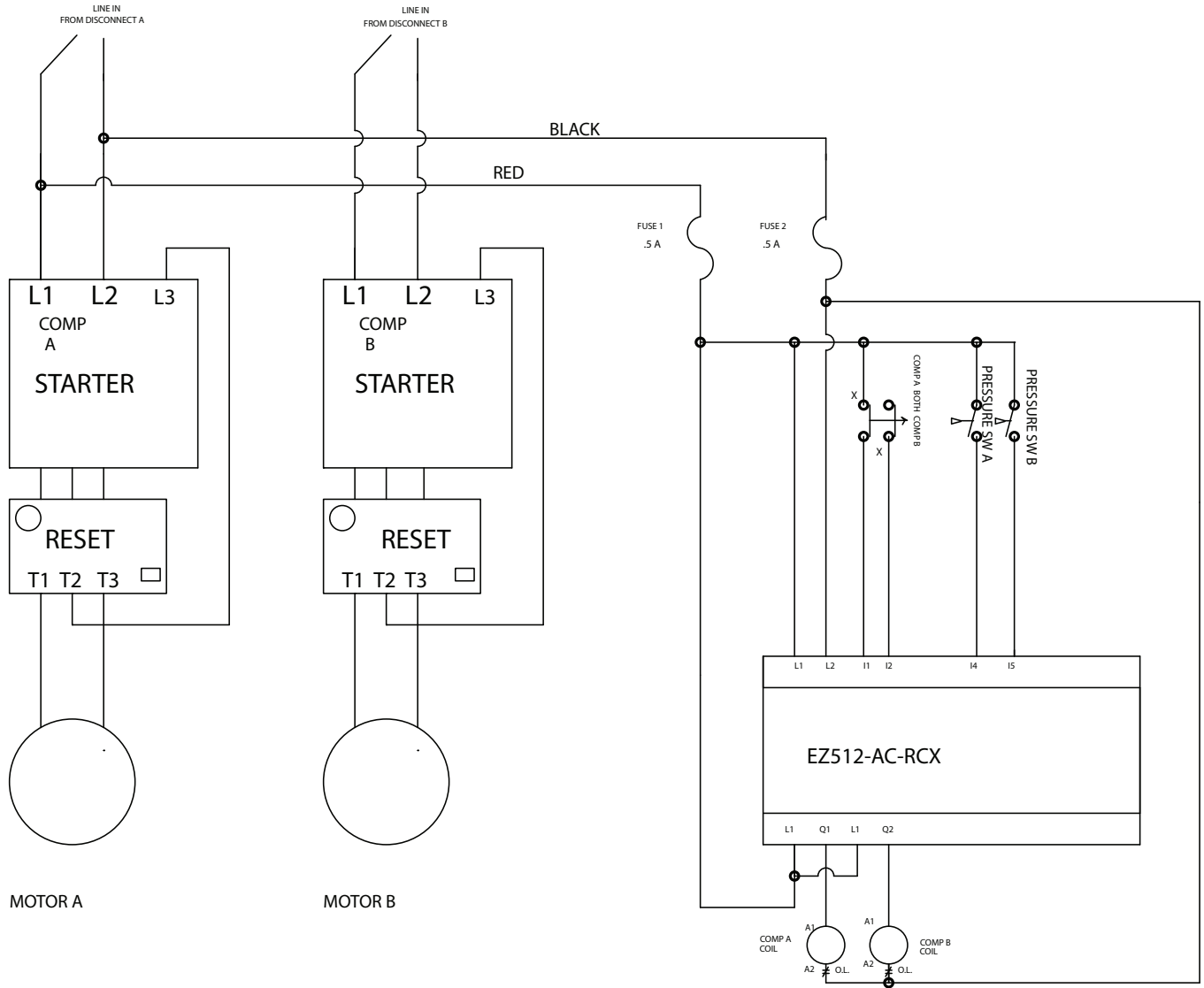

**DUPLEX UNITS ONLY** Wiring Diagram for 82289049  
**Three Phase 208/230 Volt Controller / Magnetic Starters**

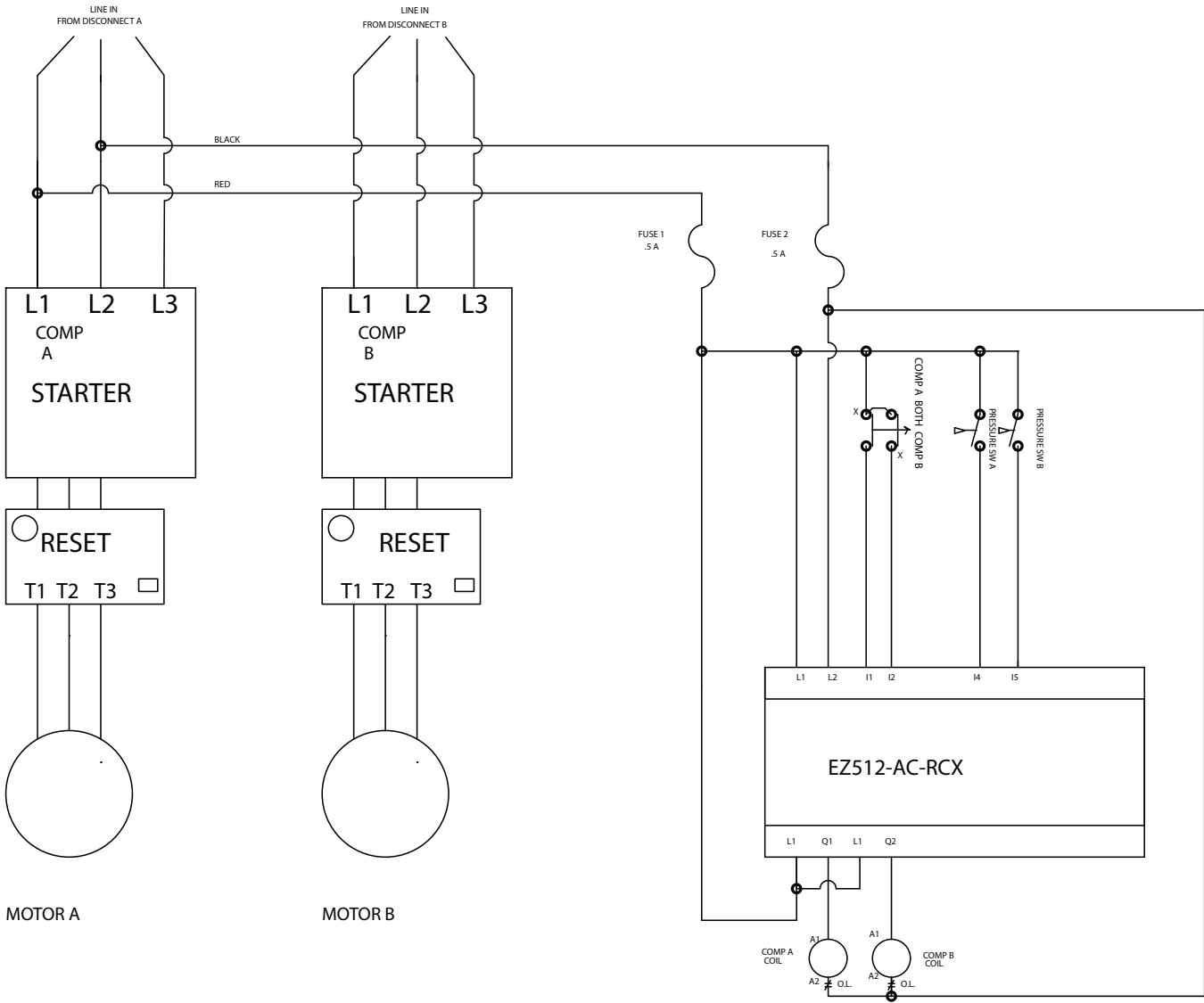

**DUPLEX UNITS ONLY** Wiring Diagram for 82289050  
**Three Phase 480 Volt Controller / Magnetic Starters**

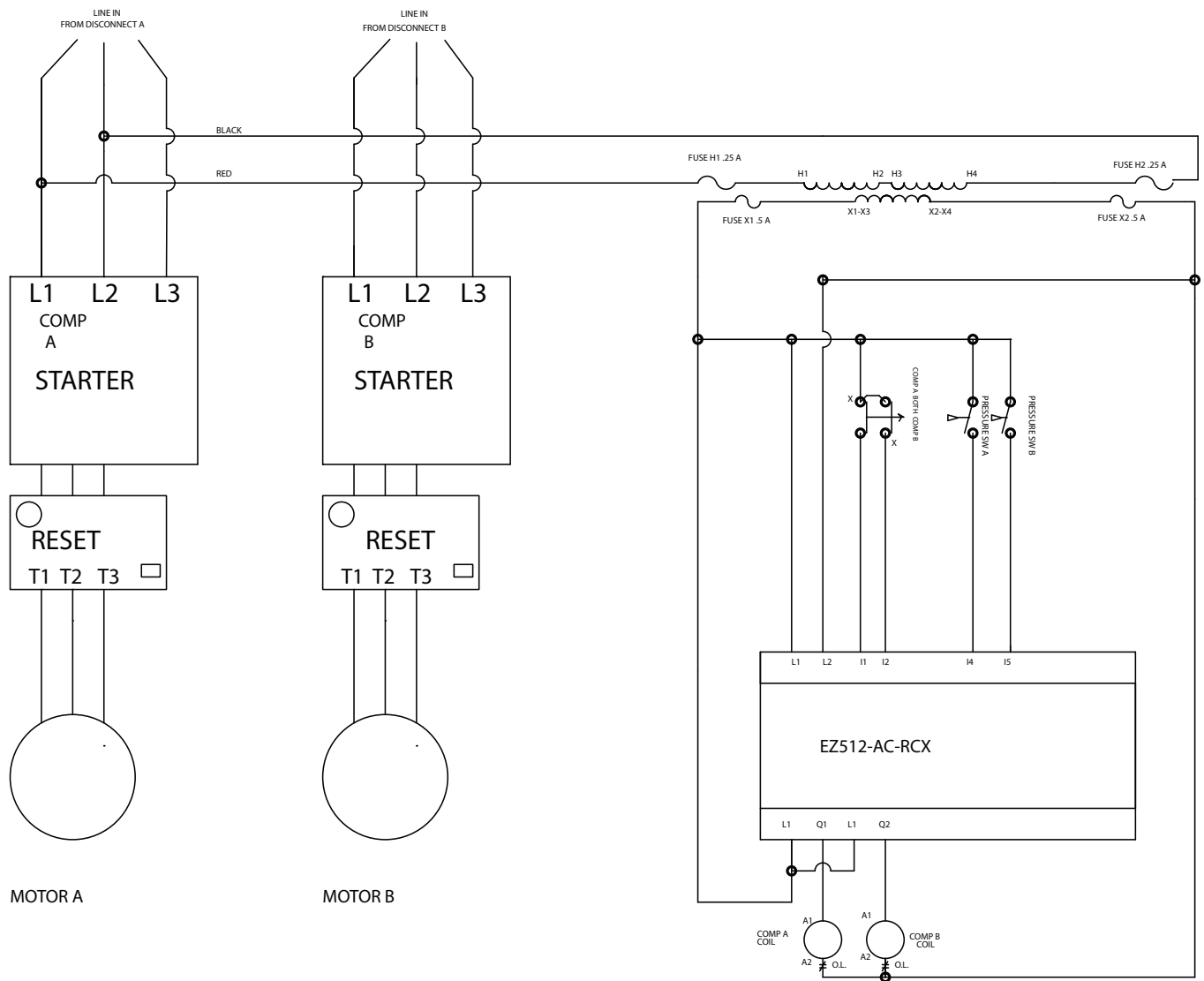

## MAINTENANCE SCHEDULE - CHECK CHART

PROCEDURE	Daily	Weekly	Monthly	Quarterly	Yearly
Check Oil Level. Caution! Do not overfill.	X				
Give Compressor overall visual check.	X				
Drain moisture accumulation from the air receiver and system piping.	X				
Check the air distribution system for air leaks. Remove and clean intake air filters. Do not oil.		X			
Clean cooling surfaces of compressor, intercooler and aftercooler		X			
Check V-belts for tightness. Belt tension should be adjusted to allow approximately 1/4 - 1/2 inch deflection with normal thumb pressure.		X			
Turn power off and clean dust and foreign material from cylinder head, motor, fan blade, air lines, intercooler and tank.		X			
Operate safety valves (pressure relief valve).			X		
Replace or clean intake filter element monthly or more often if needed.			X		
Inspect oil for contamination and change if necessary.			X		
Check belts for correct tension and alignment.			X		
<b>Check flywheel and motor pulley for tightness. Check pulley clamp bolts and set screws for tightness.</b>			X		
Every 90 days also check entire system for air leakage around fittings, etc. using a soap solution. Tighten nuts and cap screws as required.				X	
Every 90 days or 1,000 operating hours, whichever comes first, change crankcase oil. Use type and grade recommended in paragraph on lubrication. Change oil more frequently if compressor is located in dirty environment.*				X	
Inspect valve assemblies.					XX
Inspect cushion chamber, if so equipped, and discharge line for excessive carbon accumulations.					X
Inspect pressure switch diaphragm and contact points.					X
Inspect contact points in motor starter.					X
Service electric motor.	‡	‡	‡		‡
Service gasoline engine.	‡	‡	‡		‡

X - Check more often if extremely dirty conditions exists.

XX - Every 6 months.

‡ Per Manufacturer's Recommendations.

\* Change oil after first **50 hours** (or two weeks) of operation if new or relocated.



**We are proud to offer you additional products to support your business needs.**

## **Refrigerated Dryers, Pressure Washers, and Nitrogen Generators**

### **Direct Flow - Variable Flow - High Inlet Temperature**

To ensure maximum performance of your system we can match your Air Compressor with a Refrigerated Dryer. A Refrigerated Air Dryer will pay for itself by extending the life of your tools and equipment by eliminating water vapor from the air line. Dryer installation is important to all shop air systems but absolutely critical for paint and body shops where a quality paint finish is a must.

### **Gas - Electric - Cold Water - Hot Water**

Consumer to Industrial Pressure Washers  
We sell a full Line of Pressure Washers and Accessories ranging from Light Duty to large Commercial and Industrial Pressure Washers.

### **Nitrogen Generators, Purge & Inflation Systems**

Stationary and Mobile options available. Meeting the demands of the ever-growing Tire Industry, we now offer Nitrogen Generators, Purge and Refill Systems. Nitrogen filled tires have been used in the Racing and Air craft for years. Commercial and Consumer use is on the rise. The benefits and sales opportunities of Nitrogen filled tires far outweigh the minimal setup and cost associated with this technology.

**Please call our technical support team who will be happy to direct you to a sales representative for any of the product lines listed above and/or for questions regarding additional air compressor needs.**

**1-800-288-1804 ext. 620**



## Battery Connections for Electric Starter (on gas engines)

Use a 12-volt battery with an ampere-hour rating of at least 300 CCA.

Be careful not to connect the battery in reverse polarity, as this will short circuit the battery charging system. Always connect the positive (+) battery cable to the battery terminal before connecting the negative (-) battery cable, so your tools cannot cause a short circuit if they touch a grounded part while tightening the positive (+) battery cable end.

### Warning!

A battery can explode if you do not follow the correct procedure, seriously injuring anyone nearby.

Keep all sparks, open flames, and smoking materials away from the battery.

### Warning!

Drain all air from the tank before starting. Starting the engine with air in the tank will overload the starter and may lead to starter failure.

**WARNING:** Battery posts, terminals and related accessories contain lead and lead compounds. Wash hands after handling.

1. Connect the battery's positive (+) cable to the starter solenoid.
  2. Connect other end to a 100 amp. circuit breaker (accessory side).
  3. Connect another cable to the circuit breaker (battery side).
  4. Connect cable to the battery's positive (+) side.
  5. Connect the negative (-) cable to the engine mount bolt.
  6. Connect the negative (-) cable to the battery.
- Battery cables should be #6 or #8 (braided cables with factory crimped ends).
  - Cables should not exceed 25 feet total. Positive = 25 ft. Negative = 25 ft.
  - Circuit breaker is to protect the unit and the vehicle against positive grounding.

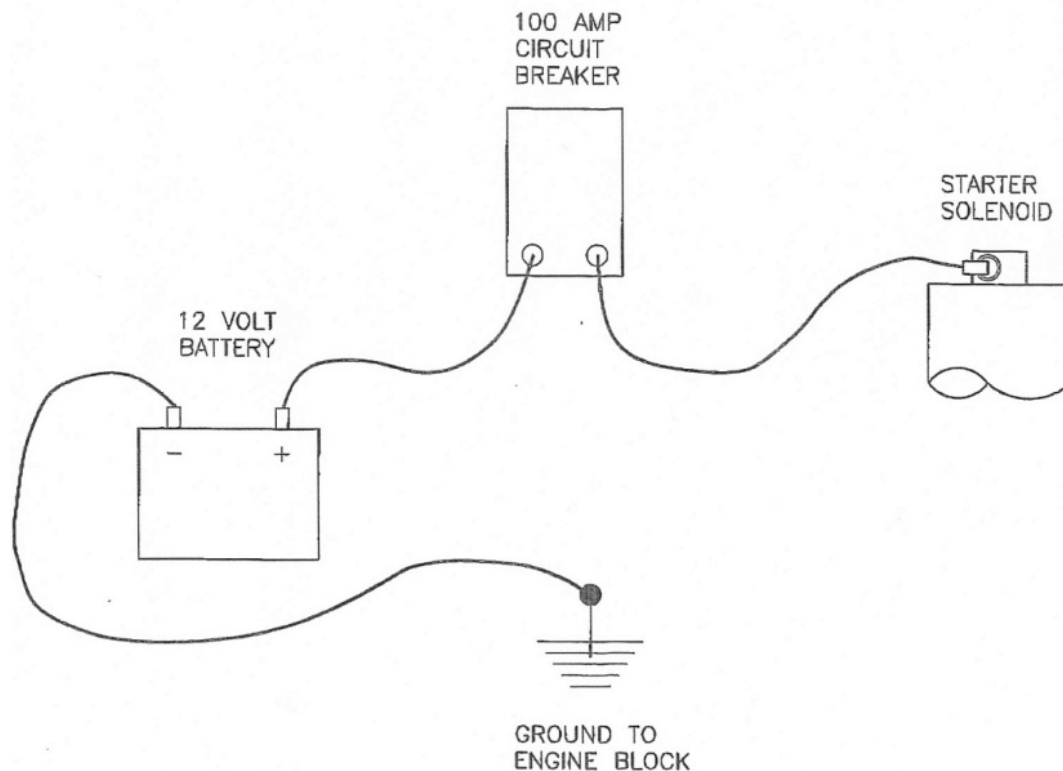

# Schrader International Inc.

## Warranty Statement

For (1) one year from the date of purchase, Schrader International Inc. will replace or repair for the original purchaser free of charge, any part or parts found upon examination by manufacturer/any Authorized Service Center to be defective in material or workmanship or both. This warranty shall not be effective unless the warranty registration certificate is completely filled out and returned to Schrader International Inc. within thirty (30) days from the delivery of the equipment to the original end-user.

All transportation charges for parts submitted for replacement under this warranty must be borne by the purchaser. There is no other express warranty. Implied warranties, including those of merchantability and fitness for a particular purpose are limited to one year from the date of purchase and to the extent permitted by law, any and all implied warranties are excluded. This is the exclusive remedy, and liability for consequential damages under any and all warranties are excluded to the extent exclusion is permitted by law.

All claims pertaining to the merchandise in this schedule must be filed with Schrader International Inc. within 12 months of the invoice date, and a registration card is on file with Schrader, or they will not be honored. Prices, discount, and terms are subject to change without notice or as stipulated in specific product quotations. All agreements are contingent upon strikes, accidents, and other causes beyond our control. All shipments are carefully inspected and counted before leaving the factory. Please inspect carefully any receipt of merchandise, noting any discrepancy or damage on the carrier's freight bill at time of delivery. Discrepancies or damage, including hidden or obvious that occurred in transit are the carrier's responsibility and related claims should be made by the customer directly with the carrier.

To locate the closest Authorized Service Center for service assistance, resolution of a service problem or for product information and operation, call or write to:

Schrader International Inc.  
205 Frazier Road  
Altavista, VA 24517

Email: TechSvc@Schrader-Bridgeport.com  
1.800.288.1804  
Tech Service, ext. 304, 868, 513

What is not covered under this warranty:

- Electric motors or gasoline engines are covered by the Original Manufacturer's Warranty and should be returned (by the customer) to their authorized service center for service.
- Consumer compressors used in commercial, industrial or rental purposes will be covered by warranty for (90) ninety days from date of purchase only.
- Any failure that results from an accident, purchaser's abuse, neglect or failure to operate products in accordance with instructions provided in the owner's manual(s) supplied with compressor.
- Pump or valve failure caused by rain, excessive humidity, corrosive environments or other contaminants.
- Cosmetic defects that do not interfere with the compressor's functionality.
- Damage due to incorrect voltage or improper wiring.
- Pump wear or valve damage caused by any oil contamination or by failure to follow proper oil maintenance guidelines.
- This warranty is invalid if the factory-applied serial number has been altered or removed from the product, or an electric compressor has been used in conjunction with a generator.
- Freight damage



**CUSTOMER SERVICE • PARTS**  
**1-800-828-0355**

**TECHNICAL SERVICE • PARTS**  
**1-800-288-1804**



Schrader International Inc.  
P.O. Box 668 • 205 Frazier Road  
Altavista, Virginia 24517