



20 Gallon Air Compressor

Model: 52401



**Actual product may vary slightly*

Please carefully read and save these instructions before attempting to assemble, maintain, install, or operate this product. Observe all safety information to protect yourself and others. Failure to observe the instructions may result in property damage and/or personal injury. Please keep instructions for future reference.

For warranty purchases, please keep your dated proof of purchase. File or attach to the manual for safekeeping.



Important Operating Instructions

CALIFORNIA PROPOSITION 65

WARNING: You can create dust when you cut, sand, drill or grind materials such as wood, paint, metal, concrete, cement, or other masonry. This dust often contains chemicals known to cause cancer, birth defects, or other reproductive harm. Wear protective gear.

WARNING: This product or its power cord may contain chemicals, including lead, known to the State of California to cause cancer and birth defects or other reproductive harm. Wash hands after handling.

Important!

When using equipment, a few safety precautions must be observed to avoid injuries and damage. Please read the complete operating manual with due care. Keep this manual in a safe place, so that the information is available at all times. If you give the equipment to any other person, give them these operating instructions as well. We accept no liability for damage or accidents which arise due to non-observance of these instructions and the safety information herein.

SPECIFICATIONS

Running horsepower:	2 HP
Maximum Pressure:	130 PSI
CFM @ 40 PSI:	6 CFM
CFM @ 90 PSI:	4 CFM
Voltage:	Single Phase; 120V
Motor:	3300 RPM
Tank:	20 gallons

Oil Free Direct Drive Pump

Any failures made in following the safety regulations and instructions may result in an electric shock, fire, and/or serious injury.



Important Operating Instructions

GENERAL SAFETY INSTRUCTIONS

- Keep work area clean. Messy areas and cluttered workbenches invite personal injury and/or property damage.
- Keep children and visitors away. All children should be kept away from the work area. DO NOT let children handle the compressor or extension cord. Maintain a safe distance for any person near the work area.
- Operating any tools or equipment under the influence of drugs, alcohol, or medication can cause personal injury to yourself and others.
- Wear proper apparel. Remove your jewelry before using air compressor. Do not wear loose clothing, necklaces, rings, bracelets, or other jewelry, which may get caught in moving parts. Nonskid footwear and electrically non-conductive gloves are highly suggested while working. Wear protective hair covering to contain long hair.
- Protect your eyes. The operation of any air compressor can result in foreign objects being thrown into the eyes, which can result in severe eye damage. Always wear eye protection that meets ANSI Z28.1 specifications during air compressor operation. Eyeglasses are not always safety glasses.
- Be responsible for your hearing. Wear hearing protection during extended periods of operation.
- Use the right tool. Use tools properly and for their intended use. Do not force a small tool to do the job of a heavy-duty tool. Using the right tool to do the right job will make doing the job safer.
- Check damaged parts before use of any air tools or attachments. A guard or other part that is damaged should be carefully checked to ensure that it will operate properly and perform its intended function. Check for misalignment or binding of moving parts, breakage of parts, mounting, or any other conditions that may affect tool operation. A guard or other part that is damaged should be properly replaced. See replacement parts list for additional details.
- Avoid unintentional starting. Be sure that your air compressor is in the OFF position before plugging it into a power cord or electrical receptacle.
- Store all maintenance tools away from the immediate area before turning ON your air compressor.



Important Operating Instructions

GENERAL SAFETY INSTRUCTIONS

- Do not overreach. Proper footing and balance is a must at all times while using tools. Unstable support may lead to personal injury. Do not stand on the tool. Serious injury could result if the tool tips over or you accidentally contact the tool.
- Never leave the air compressor running unattended. Always turn the power to the OFF position and do not leave the air compressor until it comes to a complete stop.
- When using air accessories, consult the owner's manual provided by the manufacturer. The use of improper accessories may cause risk of injury to yourself and others.
- Always make sure the tool is in the OFF position and unplugged from the electrical receptacle when making adjustments, changing parts, or performing any maintenance.
- Secure work. When possible, the use of clamps or a holding device is much safer than holding the work piece with your hands.
- Keep protective guards in place and in proper working condition.
- Maintain tools and equipment with care. They will function better and more safely when kept clean and in good working condition. Keeping the air compressor clean, dry, and free of grime will add to its life and performance.
- Childproof the workshop. The use of master switches and padlocks is highly recommended. Remove starter keys where applicable.

Drain liquid from air tank daily

- Use the drain valve located on the bottom of the lower air tank to drain. Failure to properly drain liquid from the tank will cause rust from moisture buildup, which weakens the tank and could lead to a violent tank explosion. Periodically inspect the tanks for unsafe conditions such as corrosion, cracked welds, and leaks.
- Release air slowly when draining moisture or depressurizing the air compressor. Fast moving air will stir up dust, dirt, and debris, and may be harmful.

Risk of fire or explosion

- Avoid dangerous environments. Do not spray combustible/flammable liquid in a confined area. Spray area must be well ventilated. Do not smoke while spraying or spray where spark or flame is present. Arcing parts - keep compressor at least 20 ft. away from spraying area and all explosive vapors. Do not use compressor near gasoline or other flammable materials.



Important Operating Instructions

GENERAL SAFETY INSTRUCTIONS

- Operate the air compressor in a well-ventilated area. Do not direct paint or other spray material towards the compressor. Read and follow all safety instructions for the material you are spraying.

Risk of injury

- Do not direct air stream at body. Use eye protection. Compressor starts automatically. Do not touch moving parts. Keep guards in place. Compressor does not supply breathable air.

Risk of bursting

- Do not adjust regulator to result in output pressure greater than marked maximum pressure of attachment. If a regulator has not been installed, use only attachment rated at 200 PSI or higher. Do not weld on or repair tank - **A DAMAGED TANK MUST BE REPLACED IMMEDIATELY**. Do not operate without proper safety valve in place.
- Never attempt to repair or make modifications to the tank or its attachments. Welding, drilling, or any other modifications may weaken the tank, which may result in damage from rupture or explosion. Never remove or attempt to adjust the pressure switch, safety valve, or other components that control tank pressure. Never substitute parts or attempt to alter the factory set operating pressures.

Risk of burns

- Touching exposed metal such as the compressor head or exhaust tube can result in serious burns. Keep hands and fingers away from exposed metal parts on air compressor during or immediately after operation. Air compressors generate significant heat during normal operation and will remain hot for some time after use. Do not reach around protective shrouds or attempt any maintenance until compressor has been allowed to cool.

Risk of flying objects

- Do not direct compressed air stream at people or pets. The powerful compressed air stream can damage exposed skin and easily propel loose dirt and other small objects at high-speed, resulting in serious injury. Always wear eye protection that meets ANSI Z28.1 specifications. Use only OSHA approved air blowguns. Never leave a pressurized air compressor unattended. Shut OFF air compressor and relieve pressure before performing maintenance or repairs. Do not move the air compressor while the air tank is pressurized. Never attempt to move the air compressor by pulling on the air hose.



Important Operating Instructions

GENERAL SAFETY INSTRUCTIONS

Risk of falling

- Portable air compressors can fall from a table, workbench, or roof causing damage to the compressor and could result in serious injury or death to the operator. Always operate air compressor in a stable and secure position to prevent accidental movement of the unit. Never operate air compressor on a roof or other elevated position. Use additional air hose to reach high locations.

Air tools and accessories

- Do not exceed the pressure rating of any air tool, spray gun, air accessories, or inflatables. Excess pressure can cause them to explode, resulting in serious injury. Follow the manufacturer's recommended pressure settings for all air tools and air accessories.

INSTALLATION & LOCATION

Caution: In order to avoid damaging the air compressor, do not allow the unit to be tilted from the normal position when operating.

The compressor must be run with the rubber feet resting on a flat and stable horizontal surface.

The air compressor must be used in a clean and well-ventilated area. The compressor requires an unobstructed airflow and must be located a minimum of 20 inches from any walls or other obstructions that may prevent proper ventilation.

Caution: DO NOT place air compressor in an area:

- Where there is evidence of oil or gas leaks.
- Where flammable gas vapors or materials may be present
- Where temperatures fall below 32°F or exceed 104°F.
- Where extremely dirty air or water could be drawn into the air compressor.

WARNING: Serious injury or death may occur if electrical sparks from motor and pressure switch come in contact with flammable vapors, combustible dust, gases, or other combustible materials. When using the air compressor for spraying paint, place the air compressor as far away from the work as possible, using extra lengths of air hose to extend the working reach instead of extension cords.



Important Operating Instructions

GROUNDING INSTRUCTIONS

This product should be grounded. In the event of an electrical short circuit, grounding reduces the risk of electric shock by providing an escape wire for the electric current. This product is equipped with a cord having a grounding wire with an appropriate grounding plug. The plug must be plugged into an outlet that is properly installed and grounded in accordance with all local codes and ordinances.

DANGER: Improper installation of the grounding plug can result in a risk of electric shock. If repair or replacement of the cord is necessary, do not connect the grounding wire to either flat blade terminal. The wire with GREEN insulation with or without yellow stripes is the grounding wire.

This product is for use on a nominal 120-volt circuit and has a three-prong grounding plug that looks like the plug illustrated in Figure 1. A temporary adapter similar to the adapter illustrated in Figure 1-B may be used to connect this plug to a 2-pole receptacle as shown in figure 1-B when a properly grounded outlet is not available. The temporary adapter shall be used only until a properly grounded outlet (Figure 1-A) is installed by a qualified electrician. Tab for grounding screw, lug, or similar part extending from the adapter must be connected to a permanent ground such as a properly grounded outlet box cover. Whenever the adapter is used, it must be held in place by a metal screw.

The use of a GFCI outlet is strongly recommended. The third prong is to be used to ground the tool and provide protection against electrical shock. Never remove the third prong.

Check with a qualified electrician or serviceman if the grounding instructions are not completely understood, or if in doubt as to whether the product is properly grounded. Do not modify the plug provided. If it will not fit the outlet, have the proper outlet installed by a qualified electrician.

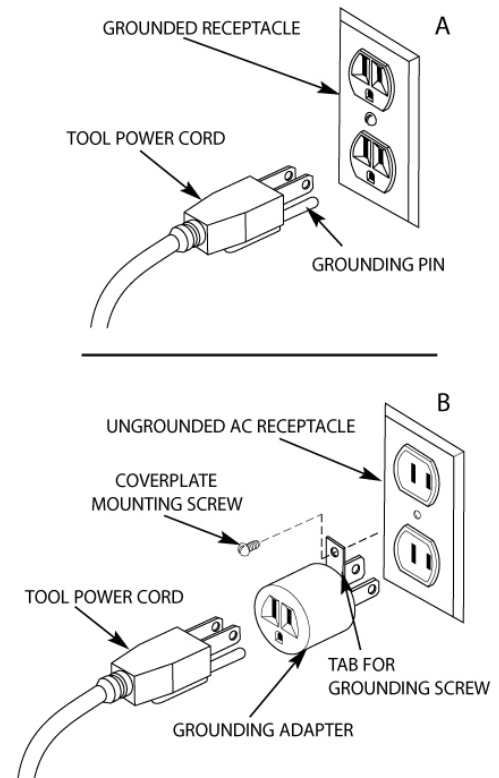

FIGURE 1. CONNECTING THE AIR COMPRESSOR TO THE AC POWER RECEPTACLE



Important Operating Instructions

EXTENSION CORDS

CAUTION: The use of an extension cord with this product is not recommended as this can result in the loss of power to your air compressor which can prevent the motor from starting or running properly. This can also cause your fuse to blow or circuit breaker to trip. Running your air compressor on an undersized extension cord will cause permanent damage to internal switches and overheating of the electric motor. Use an additional length of air hose rather than an extension cord.

If you must use an extension cord, it should be plugged into a GFCI found in circuit boxes or protected receptacles. Use only UL listed 3-wire extension cords that have a 3-blade grounding plug and a 3-slot receptacle that will accept the plug on the product. Make sure your extension cord is in good condition. When using an extension cord, be sure to use one heavy enough to carry the current your product will draw. Refer to the guide for minimum gauge required for extension cords.

EXTENSION CORD LENGTH	WIRE SIZE (AWG)
Up to 25 Feet (7.6m)	12
26 to 50 Feet (7.9m - 15.2m)	Do Not Use
51 to 100 Feet (15.5m - 30.5m)	Do Not Use

Use only extension cords that are intended for outdoor use. These cords are identified by a marking "ACCEPTIBLE FOR OUTDOOR APPLIANCES, STORE INDOORS WHEN NOT IN USE." Examine extension cord before use. **DO NOT USE DAMAGED EXTENSION CORDS.** Do not pull on cord to disconnect from receptacle; always disconnect by pulling on plug. Keep cord away from heat and sharp edges. Always shut OFF the air compressor AUTO/ON pressure switch before unplugging the compressor. Always disconnect the extension cord from the receptacle before disconnecting the product from the extension cord.

WARNING: Avoid electrical shock hazard. Never use this compressor with a damaged or frayed electrical cord or extension cord. Inspect all electrical cords regularly. Never use in or near water or in any environment where electric shock is possible. To reduce the risk of electrocution, keep all connections dry and off the ground. Do not touch the plug with wet hands.



Important Operating Instructions

Guard against electrical shock. Avoid body contact with grounded services such as pipes, ovens, stoves, and refrigerator enclosures. If not properly grounded, this air compressor can incur the potential hazard of light trickle shock, particularly when used in damp locations. If electrical shock occurs, there is the potential of secondary hazard such your hands contacting an operating air tool.

DUTY CYCLE

DUTY CYCLE

This air compressor pump is capable of running continuously. However, in order to prolong the life of your air compressor, it is recommended that a 50% average duty cycle be maintained. Duty cycle refers to the percentage of time a compressor can safely run within a given amount of time expressed as a ratio. Example: Oil lubricated compressors are typically rate at a 50% duty cycle, meaning that the compressor motor can run about 50% of the total time it is being used to supply air to a tool. During the ON time, the motor is running to pressurize the tank. During the OFF time, the motor is stopped and the tools are running off on the pressurized air stored in the tank. If your air tools are draining pressure off of the tank too quickly, the compressor motor must run more than 50% of the time the compressor is in use. This can lead to overheating and will significantly shorten the life of the compressors.

This compressor is designed for household use only and is not intended for commercial applications. It is well suited for do-it-yourselfers with a variety of automotive and home uses.

This instruction manual is intended for your benefit. Please read and follow the safety, maintenance, and troubleshooting steps described within to ensure your safety and satisfaction. The contents of this instruction manual are based upon the latest product information available at the time of publication. The manufacturer reserves the right to make product changes at any time without notice.

WARNING: Read and understand this entire instruction manual before attempting to assemble, install, operate, or maintain this air compressor. Failure to comply with the instructions may result in serious personal injury and/or property damage.

SAVE THESE INSTRUCTIONS FOR FUTURE REFERENCE.



Important Operating Instructions

WARNING: Do not operate this air compressor if damaged during shipment, handling, or misuse. Damage may result in bursting, which can cause serious injury or property damage. All damaged parts must be repaired or replaced as needed prior to operating this air compressor.

Check to see that all nuts, bolts, and fittings are secure before putting this air compressor into service. If you have any questions, or require assistance with damaged or missing parts, please contact our customer service center.

READ ALL SAFETY WARNINGS BEFORE USING THIS AIR COMPRESSOR.

COMPRESSOR FEATURES

1. AUTOMATIC ON/OFF PRESSURE SWITCH: This compressor is equipped with an automatic ON/OFF pressure switch. The compressor will only run when the switch is in ON/AUTO position. Once the tank has reached the desired preset pressure (“cut-out” pressure), the pump motor will automatically shut off. While the switch is in the ON/AUTO position, the pump motor will automatically turn back on once the pressure in the tank drops below the minimum preset pressure (“cut-in” pressure).

WARNING: Do not leave the compressor unattended while the power switch is in the ON/AUTO position.

2. AIR TANK PRESSURE GAUGE: The tank pressure gauge provides a reading of the air pressure inside of the compressor tank.

3. OUTLET PRESSURE GAUGE: The outlet pressure gauge provides a reading of the air pressure at the outlet side of the regulator. This pressure is controlled by the pressure regulator and is always less than or equal to the air tank pressure.

4. DUAL AIR COUPLERS: The air couplers are preinstalled into standard 1/4” NPT (F) threads in the pressure manifold. Use PTFE thread-sealing tape on the threads to make sure you have an airtight connection when replacing quick connect couplers.

5. PRESSURE REGULATOR: The regulator allows you to select the amount of air pressure that is output through the air hose into tools and accessories. Turn the pressure regulator knob clockwise to increase discharge pressure, and counter clockwise to decrease discharge pressure. Please refer to the air delivery requirements of your tools for the proper pressure settings.

NOTICE: Be careful not to over tighten pressure regulator knob when it “bottoms out” as this may damage pressure regulator.



Important Operating Instructions

6. SAFETY RELIEF VALVE: This compressor is equipped with a safety relief valve that is designed to prevent system failures by relieving pressure from the system when the air pressure reaches a predetermined level. The safety relief valve is preset by the manufacturer. **DO NOT** attempt to modify or remove the safety relief valve.

7. AIR TANK DRAIN VALVE: Moisture is produced whenever air is compressed. It is critical to drain water from the air tank on this compressor frequently. If unit is used only occasionally, tank should be drained after each use and prior to the next use. To drain the tank, slowly open the tank drain fitting by turning counterclockwise. Once all moisture has drained out, close the fitting securely. **NOTE:** Air tank will not pressurize while drain valve is open.

NOTE: A dirty air filter will reduce air compressor performance and can lead to product failure.

8. MANUAL THERMAL OVERLOAD SWITCH: The electric motor has a manual thermal overload protector. If the motor overheats for any reason, the thermal overload protector will shut off the motor. Turn pressure switch to the OFF position and wait for unit to cool before pushing the reset button and restarting the compressor. **NOTICE:** This air compressor is designed for household use only and is not intended to operate heavy-duty air tools. If your application's demands exceed the capacity of this air compressor, a larger air compressor that is matched to your application is recommended. If the unit shuts down again, please call the customer service center for additional assistance.

9. AIR INTAKE FILTER: This compressor is equipped with an externally accessible air intake filter that is designed to clean air coming into the pump. The filter

element is easily removed for periodic cleaning. Use compressed air to blow loose dirt and debris from the paper filter element and reinstall. Replace filter element when necessary.

10. HANDLE: Convenient handle for easy transport.

OPERATING

INITIAL SET-UP/BREAK-IN PROCEDURE:

Caution: Do not attach air hose, air tools, or other accessories to the air outlet until break-in procedure has been successfully completed.

1. Read and understand the entire instruction manual, including all safety warnings before setting up air compressor.
2. Place air compressor on a flat, level surface.



Important Operating Instructions

3. Turn the pressure regulator knobs fully clockwise to open airflow from air outlet port.

NOTE: Be careful not to over tighten pressure regulator knob when it “bottoms out” as this may damage pressure regulator.

4. Turn the power switch to the OFF position.

5. Plug the power cord directly into a properly grounded power source of the correct voltage (see Grounding instructions).

6. Open the tank drain valve to allow air to escape preventing air pressure buildup in the air tank.

7. Turn the compressor ON by moving the switch to the AUTO/ON position and run the air compressor for a period of 20 minutes to break-in the air pump.

8. With the compressor still running, at the end of the 20-minute break-in period, close the tank drain valve. The air compressor will build air pressure to the maximum preset pressure (“cut-out” pressure) and automatically shut-off.

9. Slowly turn the tank drain valve to open airflow from drain and bleed off air from the air tank. The air compressor will automatically restart once the pressure in the air tank drops below the minimum preset pressure (“cut-in” pressure).

10. Turn the compressor off by moving the switch to the OFF position.

11. Release the pressure from the system. Drain moisture from the air tank by slowly opening the air tank drain valve by turning counterclockwise. Tilt tank to remove all moisture. Once all the moisture has drained out, close the fitting securely.

NOTE: Air tank will not pressurize while drain valve is open.

12. Disconnect the power cord from the power outlet.

NOTE: Make sure the power switch is in the OFF position when connecting or disconnecting power cord from electrical outlet.

13. Your new air compressor is now ready to use.



Important Operating Instructions

MAINTENANCE

WARNING: Disconnect air compressor from the power source and bleed off all air pressure before attempting any maintenance or repair.

SHUTDOWN & STORAGE

NOTE: NEVER stop the air compressor by unplugging it from the power outlet as this may result in damage to the compressor.

1. Turn the switch to the OFF position.
2. Disconnect the power cord from the power outlet. Disconnect the power cord from the power outlet by grabbing the plug (not the cord). Loop around electric cord holder for storage.
3. Turn the pressure regulator knob fully counterclockwise to close airflow from air outlet port. Check the outlet pressure gauge to ensure that it reads 0 PSI.
4. Remove the air hose and any air accessories.
5. Drain moisture from the air tank by slowly opening the air tank drain valve by turning counterclockwise. Tilt tank to remove all moisture. Once all the moisture has drained out, close the fitting securely.
6. Allow the compressor to cool down.
7. Wipe the air compressor clean and store it in a clean, dry, and non-freezing location.

WHEN PERFORMING ANY MAINTENANCE OR SERVICE:

1. The air compressor must be turned off.
2. Disconnect compressor from the power source.
3. Open tank drain to bleed off all air pressure before attempting any maintenance or repair.
4. Allow compressor to fully cool before attempting any maintenance or repair. Check the air compressor frequently for any visible problems and follow maintenance procedures each time the compressor is used.



Important Operating Instructions

MAINTENANCE CHECKLIST

Daily:

- Drain accumulated liquid from tank
- Check for unusual noise and/or vibrations
- Check that all fasteners are secure
- Wipe compressor clean

Weekly:

- Inspect and clean air filter

Monthly:

- Check for air leaks
- Check safety relief valve

CHECKING SAFETY RELIEF VALVE

WARNING: Safety relief valve must be replaced if it cannot be actuated or it leaks air after the ring is released.

1. The air compressor must be turned OFF.
2. Disconnect compressor from the power source.
3. Open tank drain to bleed off all air pressure before attempting any maintenance or repair.
4. Allow compressor to fully cool before attempting any maintenance or repair.
5. Grasp the wire ring on the safety relief valve.
6. Pull and release the ring a few times to ensure that the plunger moves in and out. Replace the safety relief valve if plunger does not move or is difficult to move.



Important Operating Instructions

CHECKING AIR FILTER ELEMENT

1. The air compressor must be turned OFF.
2. Disconnect compressor from the power source.
3. Open tank drain to bleed off all air pressure before attempting any maintenance or repair.
4. Allow compressor to fully cool before attempting any maintenance or repair.
5. Remove the face of the filter body to access the filter element by removing screw holding filter in place.
6. Use compressed air to blow loose dirt and debris from the paper filter element. Replace filter element if it cannot be cleaned sufficiently.
7. Reinsert filter element into filter body and reinstall filter faceplate.

MOISTURE IN COMPRESSED AIR

Moisture is a normal by-product of compressing air. As the moisture builds during compressor use, it can be carried through the air hose. When using paint spray gun or sandblasting gun, the use of a special filter to remove moisture from the air line is highly recommended. Moisture in the compressed air will cause water spots in paint jobs and cause blasting media to clog the sandblasting gun.



Important Operating Instructions

TROUBLESHOOTING GUIDE

Symptom	Possible Cause(s)	Corrective Action
The compressor does not start or restart	Power cord not plugged in	Plug cord into grounded outlet
	Motor/Pressure switch in OFF position	Move switch to AUTO position
	Motor thermal overload switch has tripped	Turn air compressor off, wait until the motor is cool, then press motor thermal overload (red) button firmly until click is heard.
	Fuse blown or circuit breaker has tripped	Replace fuse or reset circuit breaker
		Check for proper fuse amperage
		Check for low voltage conditions
		Disconnect any other electrical appliances from circuit or operate air compressor on its own branch
	Wrong gauge wire or length of extension cord	Check chart in instruction manual for proper gauge wire and cord length.
	Air tank pressure exceeds motor/pressure switch "cut-in" pressure	Motor will start automatically when air tank pressure drops below "cut-in" pressure of motor/pressure switch
Pressure release valve on motor/pressure switch has not unloaded pump head pressure	Bleed the line by moving the switch to the OFF position	
Defective motor, motor capacitor, motor/pressure switch	Contact customer service	



Important Operating Instructions

TROUBLESHOOTING GUIDE

Symptom	Possible Cause(s)	Corrective Action
When in the start/stop option, motor runs continuously	Motor/pressure switch does not shut off motor when air compressor reaches “cut-out” pressure and safety relief valve activates	Move the motor/pressure switch to the OFF position. If the motor does not shut off, unplug the air compressor. If the electrical contacts are welded together, replace the pressure switch.
	Air Leaks	Check all hose & coupler fittings for leaks with soapy water. Detach leaky fittings and apply new Teflon tape. If air hose is punctured, replace.
	Air compressor is incorrectly sized	Limit the air pressure to the capacity of the air compressor. Either use a smaller tool or a larger air compressor.
Air continues to leak at motor/pressure switch release valve after motor stops	Defective pilot valve, the check valve is stuck open	Remove, clean, or replace
Air continues to leak at motor/pressure switch release valve while motor is running	Defective motor/pressure switch	Replace
	Check valve stuck in open position	Replace check valve DANGER - Do not disassemble the check valve with tank pressurized. Open tank petcock valve to allow air to escape from tank prior to servicing.
Air leaks from safety relief valve	Possible defective safety relief valve	Operate safety relief valve manually by pulling on ring. If it still leaks, it should be replaced.
	Excessive tank pressure	Defective motor/pressure switch. Replace.



Important Operating Instructions

TROUBLESHOOTING GUIDE

Symptom	Possible Cause(s)	Corrective Action
Air leaks at fittings	Fittings are not tight enough	Tighten fittings where air can be heard escaping. Check fittings with soapy water solution. DO NOT OVERTIGHTEN.
Air leaks in air tank	Defective or rusted air tank	Air tank must be replaced. DO NOT ATTEMPT TO REPAIR AIR TANK!
Air blowing from inlet filter	Damaged inlet (reed) valve	Contact customer service
Insufficient pressure at air tool or air accessory	Pressure regulator knob is not turned to high enough pressure	Adjust pressure regulator knob to proper setting
	Defective motor/pressure regulator switch	Replace
	Restricted air intake filter	Clean or replace the filter element
	Air leaks	Check for leaks by applying soap solution to all fittings and connections. Bubbles will appear at leakage points. Tighten or replace leaking fittings or connections as needed.
	Hose or hose connections are too small or long	Replace with larger hose or connectors
	Air compressor is not large enough for air requirement	Check the accessory air requirement. If it is higher than the CFM or pressure supply of the air compressor, you need a larger air compressor.
Moisture in discharge air	Condensation in air tank caused by high level of atmospheric humidity or air compressor is not running long enough	Drain tank after every use. Drain air tank more often in humid weather and use an air line filter/



Important Operating Instructions

WARRANTY

Limited Manufacturer Warranty

North American Tool Industries (NATI) makes every effort to ensure that this product meets high quality and durability standards. NATI warrants to the original retail consumer a 1-year limited warranty from the date the product was purchased at retail and each product is free from defects in materials. Warranty does not apply to defects due directly or indirectly to misuse, abuse, negligence or accidents, repairs or alterations, or a lack of maintenance. This product is intended for personal use. The warranty will be voided if used in commercial, rental, or industrial applications. NATI shall in no event be liable for death, injuries to persons or property, or for incidental, special or consequential damages arising from the use of our products. To receive service under warranty, the original manufacturer part must be returned for examination by an authorized service center. Shipping and handling charges may apply. If a defect is found, NATI will either repair or replace the product at its discretion.

DO NOT RETURN TO STORE

For Customer Service:

Email feedback@natitools.com or

Call **1-800-348-5004**

20 Gallon Air Compressor

Model: 52401

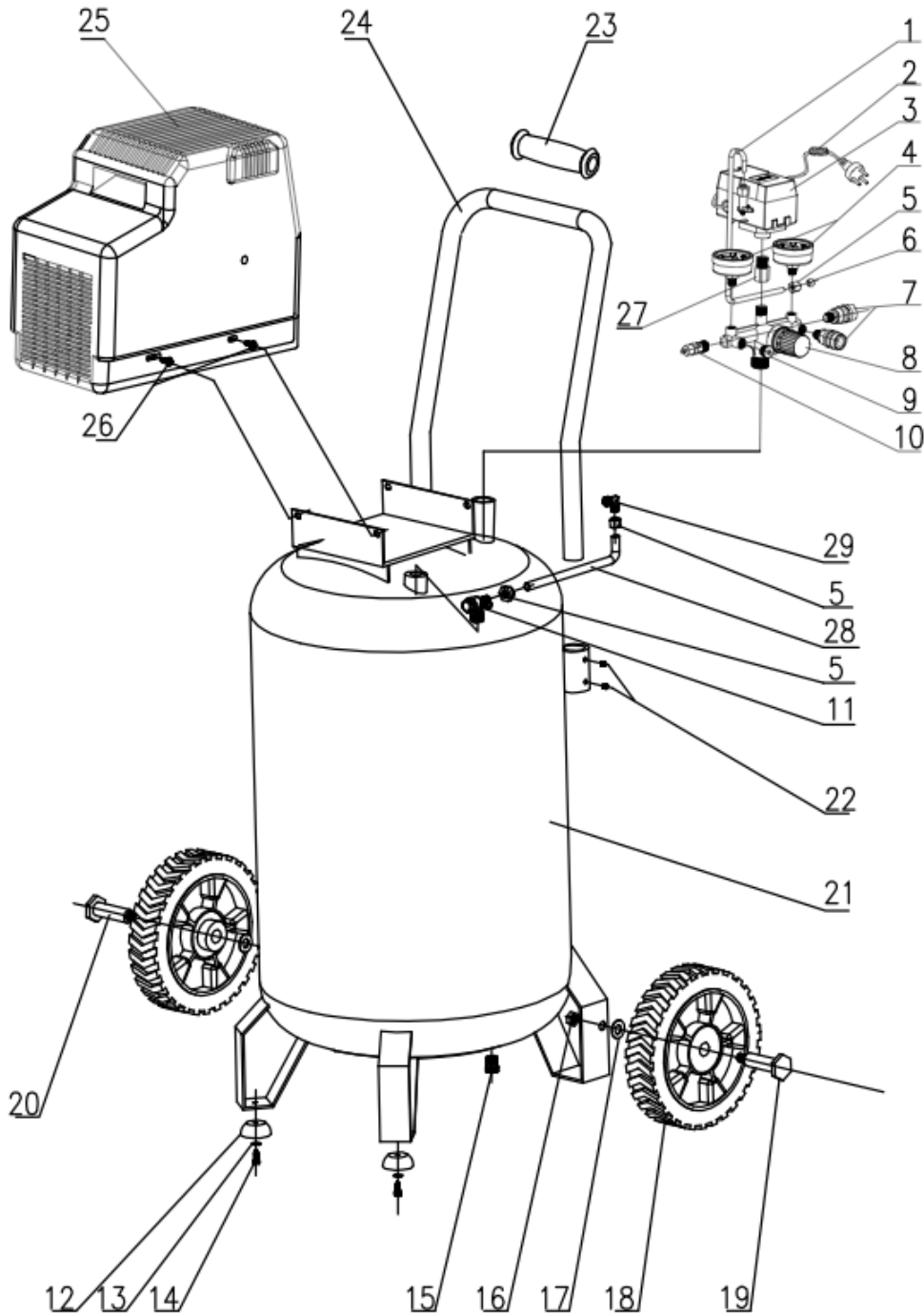

20 Gallon Air Compressor

Model: 52401

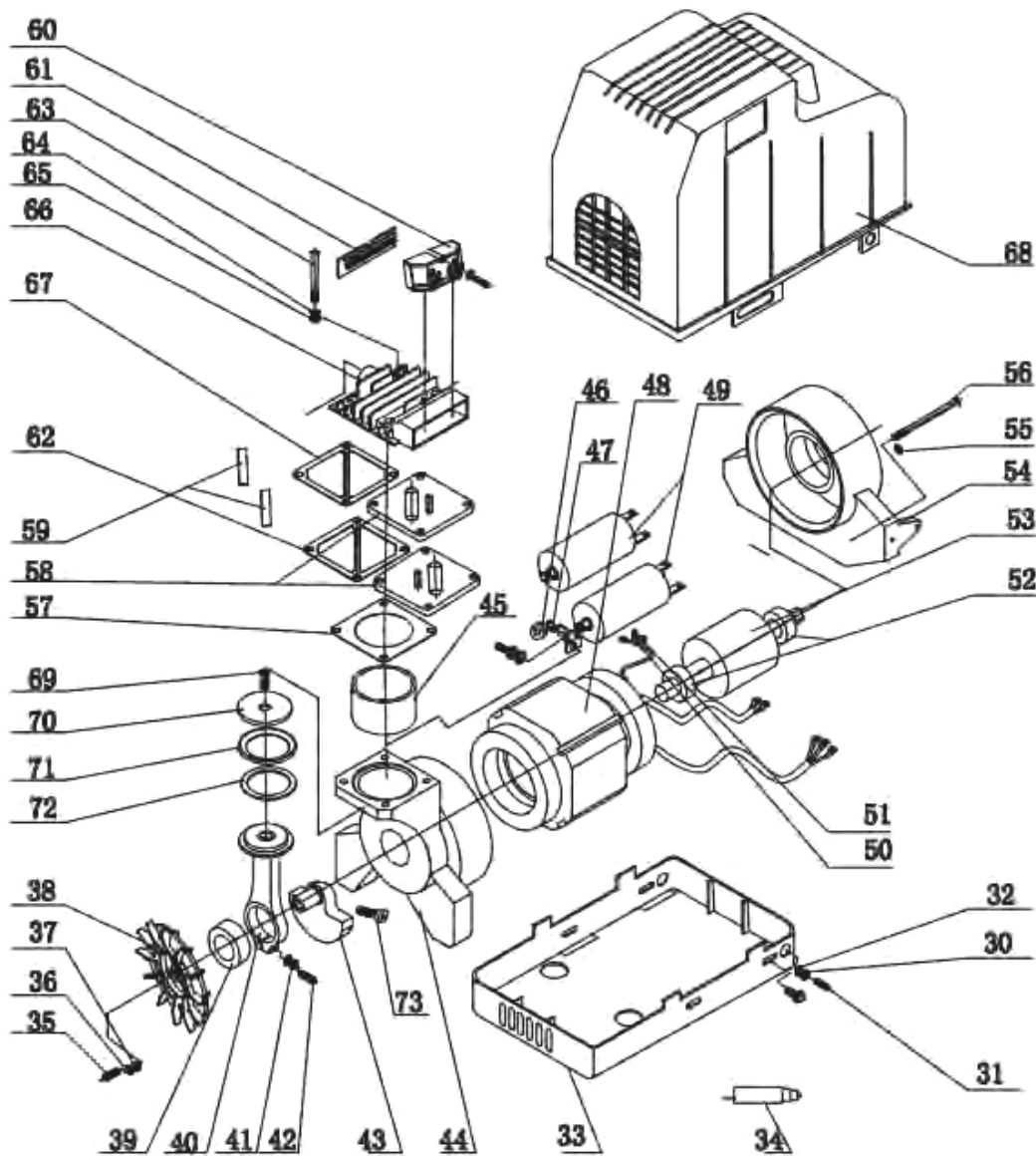



20 Gallon Air Compressor

#	Description	QTY	#	Description	QTY	#	Description	QTY
1	Release Pipe	1	28	Discharge Pipe	1	55	Spring Washer	4
2	Power Cord	1	29	Elbow	1	56	Bolt, M6	4
3	Pressure Switch	1	30	Spring Washer	1	57	Cylinder Gasket	1
4	Pressure Gauge	2	31	Bolt	1	58	Valve Plate	2
5	Nut	3	32	Washer	1	59	Reed Valve	2
6	Ring	1	33	Shroud Bottom	1	60	Filter	1
7	Quick Coupler	2	34	Circuit Breaker	1	61	Plastic Plate	1
8	Regulator	1	35	Bolt	1	62	Valve Gasket	1
9	Plug	1	36	Spring Washer	1	63	Bolt, M6	4
10	Safety Valve	1	37	Washer	1	64	Spring Washer	4
11	Check Valve	1	38	Fan	1	65	Washer	4
12	Feet Pad	2	39	Bearing	1	66	Cylinder Head	1
13	Washer	2	40	Connect-Rod	1	67	Cylinder Head Gasket	1
14	Bolt, M5	2	41	Spring Washer	1	68	Shroud Top	1
15	Drain Valve	1	42	Bolt, M5	1	69	Bolt, M6	1
16	Nut	2	43	Crank Shaft	1	70	Piston Cover	1
17	Washer	2	44	Crankcase	1	71	Piston Ring	1
18	Wheel	2	45	Cylinder	1	72	Guide Ring	1
19	Axle	1	46	Nut	1	73	Bolt	1
20	Axle	1	47	Dentiform Washer	1			
21	Tank	1	48	Stator	1			
22	Bolt	4	49	Capacitor	2			
23	Handle Grip	1	50	Bolt, M4	1			
24	Handle	1	51	Dentiform Washer	1			
25	Pump	1	52	Bearing	2			
26	Bolt	4	53	Rotor	1			
27	Connector	1	54	End Cover	1			