



# Single Stage Wheelbarrow Air Compressor

Operating Instructions and Parts Manual



**Model: FCTHEC47H9X-AXX1XX**



**Please read and save these instructions. Read carefully before attempting to assemble, install, operate or maintain the product described.**

**Protect yourself and others by observing all safety information. Failure to comply with instructions could result in personal injury and/or property damage! Retain instructions for future reference.**

**REMINDER: Keep your dated proof of purchase for warranty purposes! Attach it to this manual or file it for safekeeping.**

For parts, product & service information  
visit [www.fscurtis.com](http://www.fscurtis.com)

**FS-CURTIS, CURTIS-TOLEDO, INC.**  
1905 Kienlen Avenue, St Louis, Missouri 63133  
Tech Support: 1-800-925-5431, option 2  
Email: [info@curtistoledo.com](mailto:info@curtistoledo.com)

Model #: \_\_\_\_\_

Serial #: \_\_\_\_\_

Purchase Date: \_\_\_\_\_

REGISTER YOUR PRODUCT ONLINE NOW! <http://us.fscurtis.com/support/warranty/register>  
READ AND FOLLOW ALL INSTRUCTIONS • SAVE THESE INSTRUCTIONS • DO NOT DISCARD

## BEFORE YOU BEGIN

### Introduction

Air compressor units are intended to provide compressed air to power pneumatic tools, operate spray guns and supply air for pneumatic valves and actuators. The pumps supplied with these units have oil lubricated bearings. A small amount of oil carryover is present in the compressed air stream. Applications requiring air free of oil vapor should have the appropriate filters installed. The air compressor units are to be mounted per the instructions provided on a solid floor. Any other use of these units will void the warranty and the manufacturer will not be responsible for problems or damages resulting from such misuse.

QUICK REFERENCE
Recommended Oil (2 Options)
FSC-1000A ISO-100 Premium Reciprocating Compressor Lubricant
12 quart case part number FSC-1000A-12
1 quart part number FSC-1000A-1
For generic option use 10W30
Oil Capacity
Approximately 8.5 oz.

## UNPACKING

**⚠ CAUTION** *Do not lift or move unit without appropriately rated equipment. Be sure the unit is securely attached to lifting device used. Do not lift unit by holding onto tubes or coolers. Do not use unit to lift other attached equipment.*

After unpacking the unit, inspect carefully for any damage that may have occurred during transit. Check for loose, missing or damaged parts. Check to be sure all supplied accessories are enclosed with the unit. In case of questions, damaged or missing parts, please visit [www.fscurtis.com](http://www.fscurtis.com) for customer assistance.

**⚠ WARNING** *Do not operate unit if damaged during shipping, handling or use. Damage may result in bursting and cause injury or property damage.*

### Required Items - Not Included

- Oil for engine and pump

## GENERAL SAFETY INSTRUCTIONS

### Safety Guidelines

This manual contains information that is very important to know and understand. This information is provided for SAFETY and to PREVENT EQUIPMENT PROBLEMS. To help recognize this information, observe the following symbols.



**DANGER** Danger indicates an imminently hazardous situation which, if not avoided, WILL result in death or serious injury.



**WARNING** Warning indicates a potentially hazardous situation which, if not avoided, COULD result in death or serious injury.



**CAUTION** Caution indicates a potentially hazardous situation which, if not avoided, MAY result in minor or moderate injury.

### NOTICE

**NOTICE** Notice indicates important information, that if not followed, may cause damage to equipment.

IMPORTANT: Information that requires special attention.

### Safety Symbols

The following Safety Symbols appear throughout this manual to alert you to important safety hazards and precautions.



Wear Eye and Mask Protection



Read Manual First



Risk of Fire



Risk of Moving Parts



Risk of Hot Parts



Risk of Explosion



Risk of Fumes



Risk of Pressure



Risk of Shock

### California Proposition 65



**WARNING** This product or its power cord may contain chemicals known to the State of California to cause cancer and birth defects or other reproductive harm. Wash hands after handling.



**WARNING** You can create dust when you cut, sand, drill or grind materials such as wood, paint, metal, concrete, cement, or other masonry. This dust often contains chemicals known to cause cancer, birth defects, or other reproductive harm. Wear protective gear.

### Important Safety Information

Please read and save these instructions. Read carefully before attempting to assemble, install, operate or maintain the product described. Protect yourself and others by observing all safety information. Failure to comply with instructions could result in personal injury and/or property damage! Retain instructions for future reference.

This manual contains important safety, operational and maintenance information. If you have any questions, please visit [www.fscurtis.com](http://www.fscurtis.com) for customer assistance.

Since the air compressor and other components (material pump, spray guns, filters, lubricators, hoses, etc.) used make up a high pressure pumping system, the following safety precautions must be observed at all times:

## Important Safety Information (Continued)

### **▲ DANGER**

#### BREATHABLE AIR WARNING

This compressor/pump is not equipped and should not be used “as is” to supply breathing quality air. For any application of air for human consumption, the air compressor/pump will need to be fitted with suitable in-line safety and alarm equipment. This additional equipment is necessary to properly filter and purify the air to meet minimal specifications for Grade D breathing as described in Compressed Gas Association Commodity Specification G 7.1, OSHA 29 CFR 1910. 134, and/or Canadian Standards Associations (CSA).

#### DISCLAIMER OF WARRANTIES

In the event the compressor is used for the purpose of breathing air application and proper in-line safety and alarm equipment is not simultaneously used, existing warranties shall be voided, and FS-CURTIS, CURTIS-TOLEDO, INC disclaims any liability whatsoever for any loss, personal injury or damage.

### General Safety



- Read all manuals included with this product carefully. Be thoroughly familiar with the controls and the proper use of the equipment.
- Follow all local electrical and safety codes as well as the United States National Electrical Codes (NEC) and Occupational Safety and Health Act (OSHA).
- Only persons well acquainted with these rules of safe operation should be allowed to use the compressor.
- Keep visitors away and NEVER allow children in the work area.
- Wear safety glasses and use hearing protection when operating the unit.
- Do not stand on or use the unit as a handhold.
- Before each use, inspect compressed air system and electrical components for signs of damage, deterioration, weakness or leakage. Repair or replace defective items before using.
- Check all fasteners at frequent intervals for proper tightness.



**▲ WARNING** *Motors, electrical equipment and controls can cause electrical arcs that will ignite a flammable gas or vapor. Never operate or repair in or near a flammable gas or vapor. Never store flammable liquids or gases in the vicinity of the compressor.*



**▲ WARNING** *Carbon Monoxide can cause severe nausea, fainting or death. Do not operate unit inside a closed building or a poorly ventilated area.*



**▲ WARNING** *Never operate compressor without a beltguard. This unit can start automatically without warning. Personal injury or property damage could occur from contact with moving parts.*

- Do not wear loose clothing or jewelry that will get caught in the moving parts of the unit.

**▲ CAUTION** *Compressor parts may be hot even if the unit is stopped.*

- Keep fingers away from a running compressor; fast moving and hot parts will cause injury and/or burns.
- If the equipment should start to vibrate abnormally, STOP the engine/motor and check immediately for the cause. Vibration is generally an indication of trouble.
- To reduce fire hazard, keep engine/motor exterior free of oil, solvent, or excessive grease.

**▲ WARNING** *An ASME code safety relief valve with a setting no higher than the Maximum Allowable Working Pressure (MAWP) of the tank MUST be installed in the air lines or in the tank for this compressor. The ASME safety valve must have sufficient flow and pressure ratings to protect the pressurized components from bursting. The flow rating can be found in the parts manual. The safety valve in the intercooler does not provide system protection.*

**▲ WARNING** *Maximum operating pressure is 135 psi for single stage compressors. Do not operate with pressure switch or pilot valves set higher than 135 psi (single stage).*



### Important Safety Information (Continued)

- Never attempt to adjust ASME safety valve. Keep safety valve free from paint and other accumulations.
- Check fuel level before starting the engine. Do not fill the gas tank indoors. Wipe off any spilled gas before starting the engine.

#### **⚠ WARNING**

*Never attempt to repair or modify a tank! Welding, drilling or any other modification will weaken the tank resulting in damage from rupture or explosion. Always replace worn, cracked or damaged tanks.*

#### **NOTICE**

*Drain liquid from tank daily.*

- Tanks rust from moisture build-up, which weakens the tank. Make sure to drain tank regularly and inspect periodically for unsafe conditions such as rust formation and corrosion.
- Fast moving air will stir up dust and debris which may be harmful. Release air slowly when draining moisture or depressurizing the compressor system.
- Do not tamper with governor setting on engine. Overspeeding the unit severely shortens engine life and may also be very hazardous.



### Spraying Precautions

#### **⚠ WARNING**

*Do not spray flammable materials in vicinity of open flame or near ignition sources including the compressor unit.*

- Do not smoke when spraying paint, insecticides, or other flammable substances.
- Use a face mask/respirator when spraying and spray in a well ventilated area to prevent health and fire hazards.
- Do not direct paint or other sprayed material at the compressor. Locate compressor as far away from the spraying area as possible to minimize overspray accumulation on the compressor.
- When spraying or cleaning with solvents or toxic chemicals, follow the instructions provided by the chemical manufacturer.

Save These Instructions  
Do Not Discard

The **DANGER, WARNING, CAUTION, and NOTICE** notifications and instructions in this manual cannot cover all possible conditions and situations that may occur. It must be understood by the operator that caution is a factor which cannot be built into this product, but must be supplied by the operator.

# Getting To Know Your Compressor

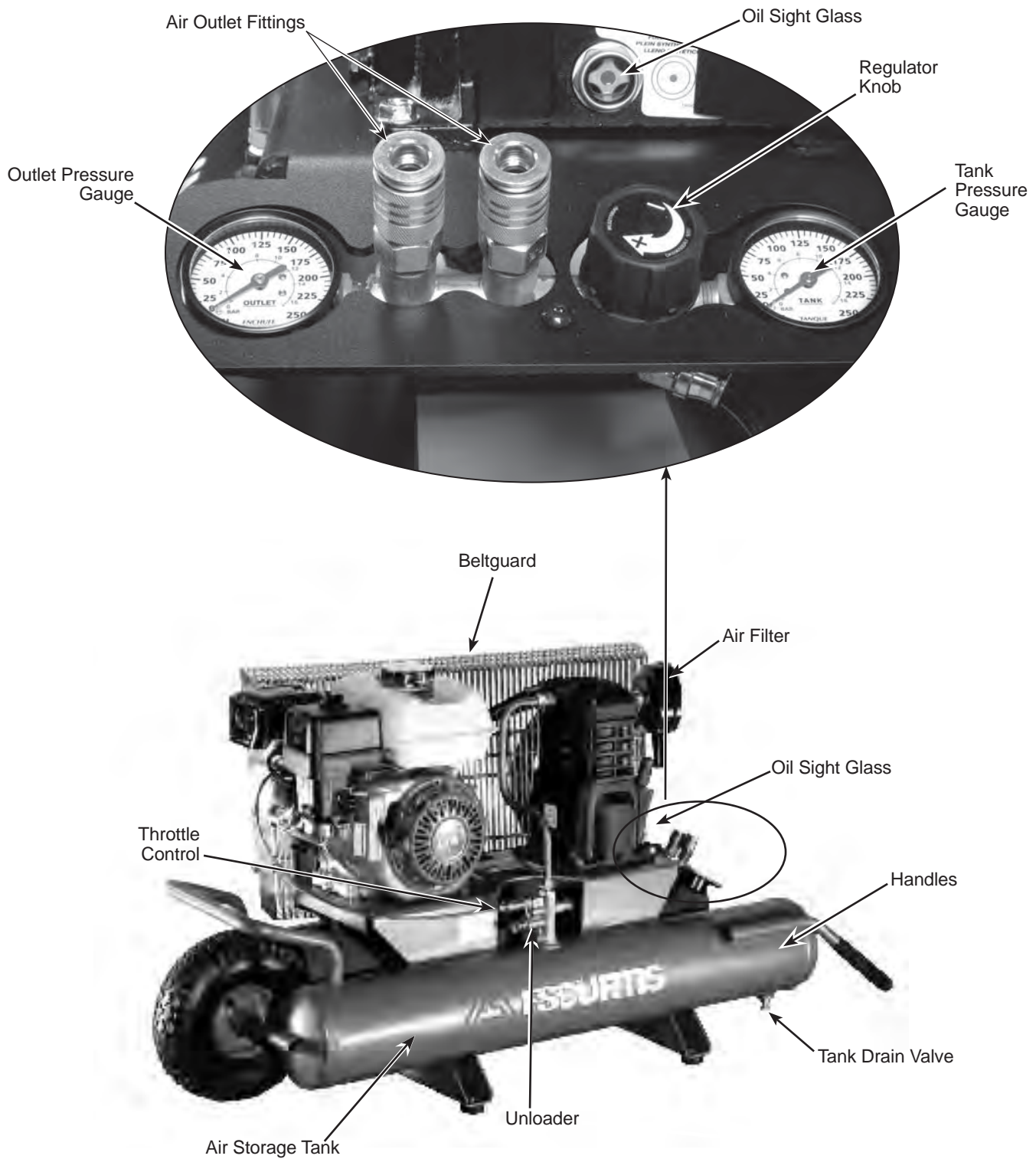

Figure 1 - Unit Identification

## SPECIFICATIONS

**FCTHEC47H9X-AXX1XX**

Engine Model	Honda GX160
Air Delivery CFM	10.2
Displacement	12.2
Max PSI	135
Pump RPM	1020
Unit Weight	176 lbs.
Max Duty Cycle	75%
Tank Outlet	1/4in. QC ( x 2)
Tank Size	9 Gallon

## DIMENSIONS

**FCTHEC47H9X-AXX1XX**

Length	48 inches
Width	26 inches
Height	18.78 inches



## INSTALLATION INSTRUCTIONS

### Lubrication

This compressor is shipped with oil.

Remove cap from oil fill opening. Install breather (found in parts bag with this manual). See Figure 2. Check oil level. See specification label on compressor pump for the proper oil capacity and oil type.

Do not use regular automotive oil. Additives in regular motor oil can cause valve deposits and reduce pump life. For maximum pump life, drain and replace oil after the first hour of run time.

This pump has an oil sight glass as shown in Figure 2. Oil level can be monitored and maintained as shown in Figure 2.

Refer to engine manual for proper oil level and type.

#### ⚠ CAUTION

*Before operating compressor, fill to the center of the sight gauge (see Figure 2).*

#### ⚠ CAUTION

*Using any other type of oil may shorten pump life and damage valves.*

Recommended Oil (2 Options)
FSC-1000A ISO-100 Premium Reciprocating Compressor Lubricant
12 quart case part number FSC-1000A-12
1 quart part number FSC-1000A-1
For generic option use 10W30
Oil Capacity
Approximately 8.5 oz.

Fill the pump with oil to the center of the sight gauge using oil fill opening (see Figure 2). **Do NOT fill the pump through the breather cap opening as this may cause oil to leak and spray out during operation.**

NOTE: Some residual oil may still be in the pump from factory testing leaving a thin coat on the sight gauge; however, there is not enough oil to operate the unit.

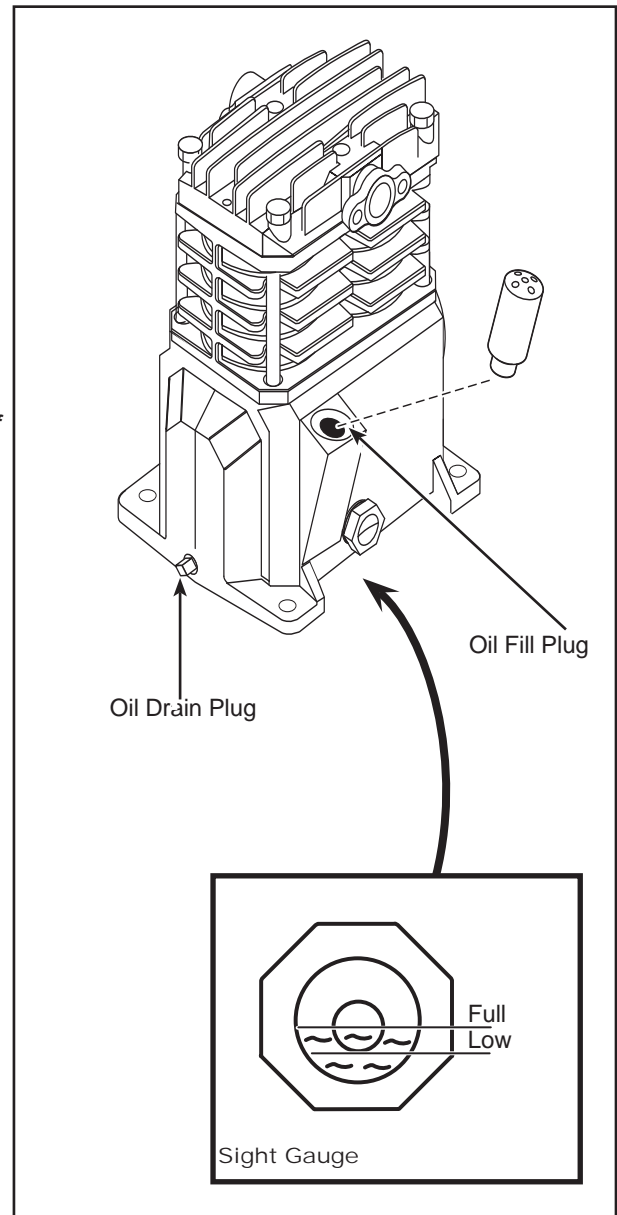

Figure 2 - Lubrication

## OPERATION

**NOTICE**

*Before starting the compressor, thoroughly read all component instruction manuals, especially the engine manual.*

All lubricated compressor pumps discharge some condensed water and oil with the compressed air. Install appropriate water/oil removal equipment and controls as necessary for the intended application.

**NOTICE**

*Failure to install appropriate water/oil removal equipment may result in damage to machinery or workpiece.*

**NOTICE**

*Drain liquid from tank daily.*

**CAUTION**

*Do not attach air tools to open end of the hose until start-up is completed and unit checks OK.*

## START-UP

**NOTICE**

*To ensure proper operation, unit must be on a level surface.*

1. Fill engine with oil and gasoline per instructions furnished with engine.
2. Check oil sight glass to verify proper oil level.
3. Turn manual unloader lever up to a horizontal position to allow the compressor pump to run without compressing air.

**TO START GASOLINE ENGINE**

1. Move the choke lever to the CHOKE position, turn the fuel lever ON, and turn the engine stop switch to the ON position.
2. Pull start grip lightly until resistance is felt, and then pull briskly.
3. As the engine warms up, gradually move the choke lever to the open position. See gas engine manual for more details.
4. Run the compressor unloaded for approximately 30 minutes to break in the pump.
5. After approximately 30 minutes, move the unloader lever down to the loaded position. The compressor will begin to pump air into the tank.

When maximum tank pressure is reached, the compressor automatically unloads, bringing the engine to idle. The engine remains at idle until tank pressure falls to a preset level. The engine then accelerates and the compressor pumps additional air into the tank.

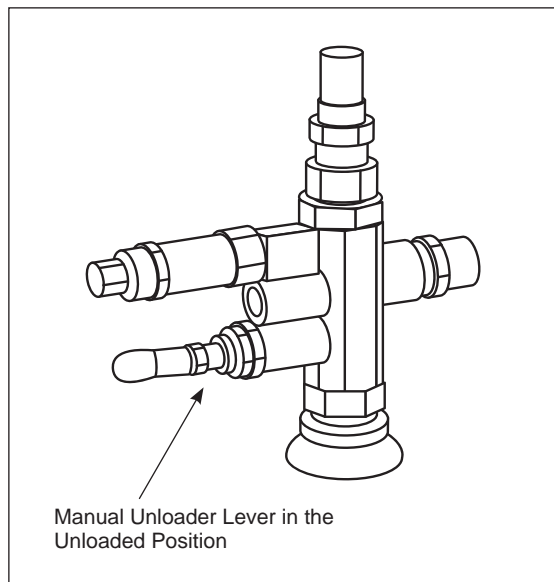

**Figure 3 - Unloader Lever Unloaded**

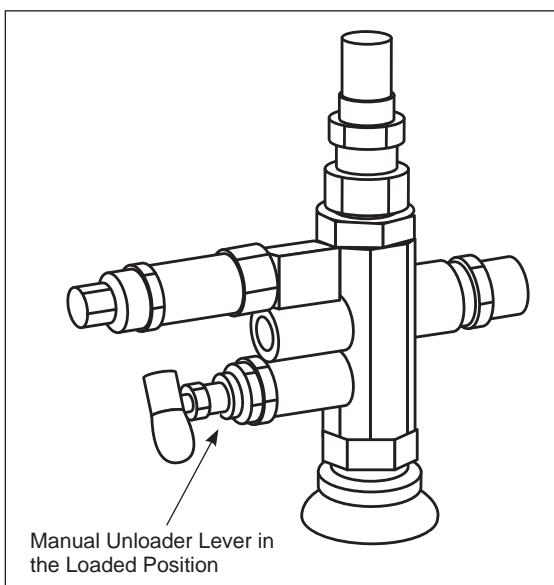

**Figure 4 - Unloader Lever Loaded**



## TROUBLESHOOTING GUIDE

SYMPTOM	POSSIBLE CAUSE(S)	CORRECTIVE ACTION
Low discharge pressure	1. Air leaks	1. Listen for escaping air. Apply soap solution to all fittings and connections. Bubbles will appear at points of leakage. Tighten or replace leaking fittings or connections.
	2. Leaking valves	2. Remove head and inspect for valve breakage, weak valves, scored valve seats, etc. Replace defective parts and reassemble.
	3. Restricted air intake	<div style="border: 1px solid black; padding: 2px; display: inline-block;"><b>CAUTION</b></div> <i>Be sure that the old head gasket is replaced with a new one each time the head is removed.</i>
	4. Slipping belts	3. Clean the air filter element.
	5. Blown gaskets	4. Loosen engine clamping bolts and move the engine in a direction away from the compressor, being sure that the engine pulley is perfectly aligned with the flywheel. Tighten engine clamping bolts. The belt should deflect about 1/2 inch under 5-lbs of force. Do not "roll" belts over pulleys.
	6. Low compression	5. Replace any gaskets proven faulty on inspection. 6. Low pressure can be due to worn rings and cylinder walls. Correction is made by replacing the rings, cylinders, and pistons as required.
Overheating	1. Poor ventilation	1. Relocate the compressor to an area where an ample supply of cool, clean, dry and well-circulated air is available.
	2. Dirty cooling surfaces	2. Clean the cooling surfaces of pump and motor-engine.
Excessive belt wear	1. Pulley out of alignment	1. Realign engine pulley with compressor pulley
	2. Belt too loose or too tight	2. Adjust tension (See Drive Belt Section).
	3. Belt slipping	3. Adjust tension or replace belt (See Drive Belt Section).
	4. Pulley wobbles	4. Check for worn crankshaft, keyway or pulley bore resulting from running the compressor or motor with loose pulleys. Check for bent pulleys or bent crankshaft.
Unit stalls	1. Low engine idle	1. Increase idle, refer to engine manual for details
	2. Improper lubrication	2. See Lubrication section of manual.
	3. Low oil level	3. Check oil level. Fill if necessary
	4. Defective unloader valve	4. Replace
Excessive noise (knocking)	1. Loose engine or compressor pulley	1. Tighten pulley clamp bolts and set-screws.
	2. Lack of oil in crankcase	2. Check for proper oil level; if low, check for possible damage to bearings. Dirty oil can cause excessive wear.
	3. Worn connecting rod	3. Replace connecting rod.
	4. Worn piston pin bushing	4. Remove piston assemblies from the compressor and inspect for excess wear. Replace excessively worn piston pin or pistons, as required.
	5. Worn bearings	5. Replace worn bearings and change oil.
	6. Piston hitting the valve plate	6. Remove the compressor head and valve plate and inspect for carbon deposits or other foreign matter on top of piston. Replace head and valve plate using new gasket.
	7. Noisy check valve	7. Replace.

## TROUBLESHOOTING GUIDE (CONTINUED)

SYMPTOM	POSSIBLE CAUSE(S)	CORRECTIVE ACTION
Oil in the discharge air	<ol style="list-style-type: none"> <li>1. Worn piston rings</li> <li>2. Compressor air intake restricted</li> <li>3. Restricted breather</li> <li>4. Excessive oil in compressor</li> <li>5. Wrong oil viscosity</li> <li>6. Connecting rod out of alignment</li> </ol>	<ol style="list-style-type: none"> <li>1. Replace with new rings.</li> <li>2. Clean filter. Check for other restrictions in the intake system.</li> <li>3. Clean and check breather for free operation.</li> <li>4. Drain down to full level.</li> <li>5. Use FSC-1000A ISO-100 Premium Reciprocating Compressor Lubricant</li> <li>6. Replace rod.</li> </ol>

## MAINTENANCE

**⚠ WARNING**

*Release all pressure from the system before attempting to install, service, relocate or perform any maintenance.*

**⚠ DANGER**

*Do not attempt to tamper with the ASME safety valve!*

In order to maintain efficient operation of the compressor system, check the air filter weekly (per maintenance schedule), oil level and gasoline level before each use. The ASME safety valve should also be checked weekly. Pull ring on safety valve and allow the ring to snap back to normal position. This valve automatically releases air if the tank pressure exceeds the preset maximum. If air leaks after the ring has been released, or the valve is stuck and cannot be actuated by the ring, the ASME safety valve must be replaced.

With engine OFF, clean debris from engine, flywheel, tank, air lines and pump cooling fins.

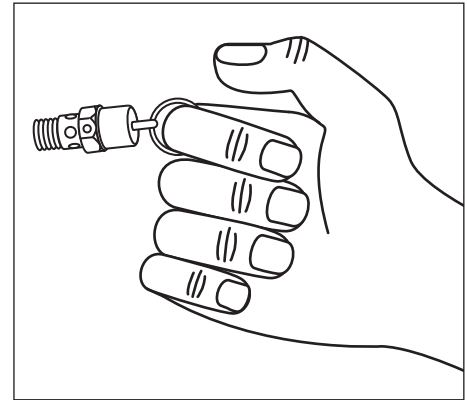

Figure 5 - Safety Valve

## Maintenance Schedule

Operation	Daily	Weekly	Monthly	3 Months
Check Oil Level	■			
Drain Tank	■			
Check Air Filter		■		
Check Safety Valve		■		
Blow Dirt from Unit		■		
Check Belt Tightness			■	
Change Oil				■

**Tank****⚠ DANGER**

*Never attempt to repair or modify a tank! Welding, drilling or any other*

*modification will weaken the tank resulting in damage from rupture or explosion. Always replace worn, cracked or damaged tanks.*

**NOTICE**

*Drain liquid from tank daily.*

The tanks should be carefully inspected at a minimum of once a year. Look for cracks forming near the welds. If a crack is detected, remove pressure from tank immediately and replace.

**FILTER REMOVAL, INSPECTION AND REPLACEMENT**

To change a filter, pull off the filter housing cover. If filter element is dirty, replace element or entire filter.



Figure 6 - Tank Drain

## MAINTENANCE (CONTINUED)

### Drive Belt

Belt stretch is a result of normal use. When properly adjusted, the belt deflects about 1/2 inch with five pounds of pressure applied midway between the engine pulley and pump.

#### To adjust drive belt tension:

1. Remove belt guard and loosen engine brace.
2. Loosen the four fasteners holding the engine to the baseplate.
3. Shift the engine in the proper direction. The belt must be properly aligned when adjustment is made.
4. To align belt, lay a straight edge against the face of the flywheel, touching the rim at two places.
5. Adjust flywheel or engine pulley so that the belt runs parallel to the straight edge.
6. Use a gear puller to move the pulley on the shaft and tighten fasteners.
7. Adjust brace and reinstall belt guard.

### Storage

1. When not in use, hose and compressor should be stored in a cool, dry place.
2. Tanks should be drained of moisture.
3. Hose should be disconnected and hung with open ends down to allow any moisture to drain.

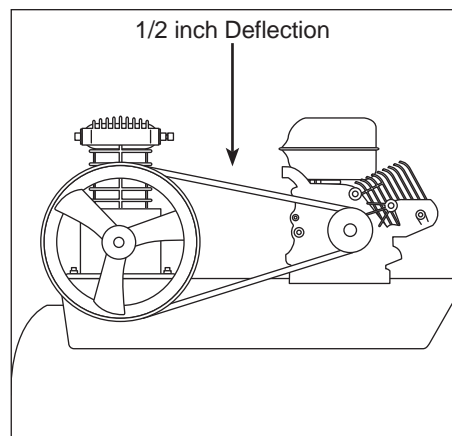

Figure 7 - Belt Deflection

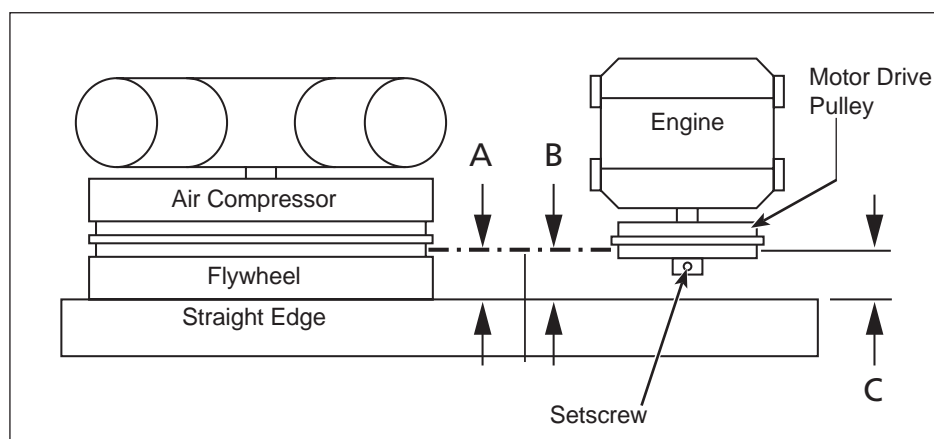

Figure 8 - Top View

### MOISTURE IN COMPRESSED AIR

Moisture in compressed air will form into droplets as it comes from an air compressor pump. When humidity is high or when a compressor is in continuous use for an extended period of time, this moisture will collect in the tank. When using a paint spray or sandblast gun, this water will be carried from the tank through the hose, and out of the gun as droplets mixed with the spray material.

**IMPORTANT:** This condensation will cause water spots in a paint job, especially when spraying other than water based paints. If sandblasting, it will cause the sand to cake and clog the gun, rendering it ineffective. A filter in the air line, located as near to the gun as possible, will help eliminate this moisture.

## REPAIR PARTS ILLUSTRATION FOR FCTHEC47H9X-AXX1XX

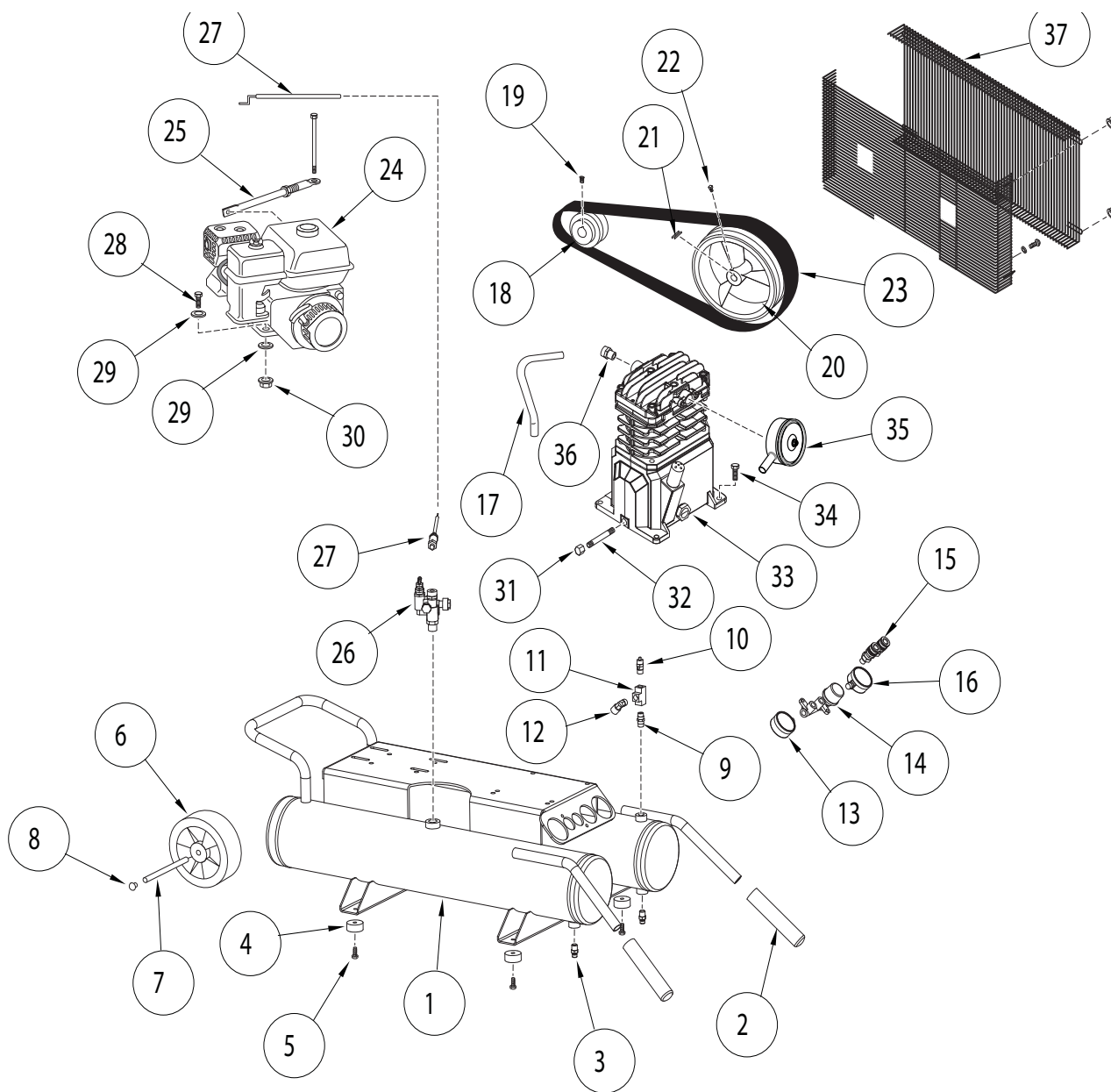

Ref No	Description	Part Number	Qty
1	TANK	FTKTTWIN9	1
2	HANDLE GRIP	■	2
3	DRAIN VALVE	■	2
4	RUBBER FOOT	■	4
5	SCREW	■	4

**For Repair Parts, visit [www.fscurtis.com](http://www.fscurtis.com) to find your local distributor**

**24 hours a day – 365 days a year**

Please provide following information:

- Model number
- Serial number (if any)
- Part description and number as shown in parts list



## REPAIR PARTS LIST FOR FCTHEC47H9X-AXX1XX

Ref No	Description	Part Number	Qty
6	10 INCH PNEUMATIC WHEEL	FW10 ■	1
7	AXLE ROD	■	1
8	PLUG	--	2
9	NIPPLE	FC47H9N	1
10	ASME SAFETY VALVE	FC47H9SV	1
11	TEE FITTING	FC47H9TC	1
12	ELBOW FITTING	▲	2
13	GAUGE, LEFT	FC47H9G ▲	1
14	REGULATOR	▲	1
15	COUPLER	--	2
16	GAUGE, RIGHT	FC47H9G ▲	1
17	DISCHARGE TUBE	▲	1
18	PULLEY	FC47H9PL	1
19	SQUARE HEAD SET SCREW	FC47H9SHS	1
20	FLYWHEEL	FCT2-5FW	1
21	KEY	FCT2-5FWK	1
22	SETSCREW	--	1
23	BELT	FC47H9B	1
24	ENGINE	FC47H9GE	1
25	BRACE ASSEMBLY	FC47H9BA	1
26	THROTTLE UNLOADER	▲	1
27	THROTTLE CONTROL	FC47H9TC	1
28	HEX HEAD SCREW	●	4
29	WASHER	●	8
30	LOCKNUT	●	4
31	OIL DRAIN CAP	--	1
32	OIL DRAIN EXTENSION	--	1
33	PUMP	FC479	1
34	SCREW	--	4
35	FILTER ASSEMBLY	FCTHE-9AFA	1
36	COMPRESSION ASSEMBLY	--	1
37	BELT GUARD ASSEMBLY	●	1
	COTTER PIN (NOT SHOWN)	■	
	REDUCER (NOT SHOWN)	▲	
	TUBE FITTING (NOT SHOWN)	▲	
<b>REPAIR PARTS KITS</b>			
■	WHEEL/HANDLE KIT	FSK-C47H9HD	
●	BELT GUARD ASSEMBLY KIT	FSK-C47H9BG	
▲	REGULATOR KIT	FSK-C47H9ULK	
--	NOT AVAILABLE		
†	AVAILABLE AT LOCAL HARDWARE STORE		

## REPAIR PARTS ILLUSTRATION FOR FC479

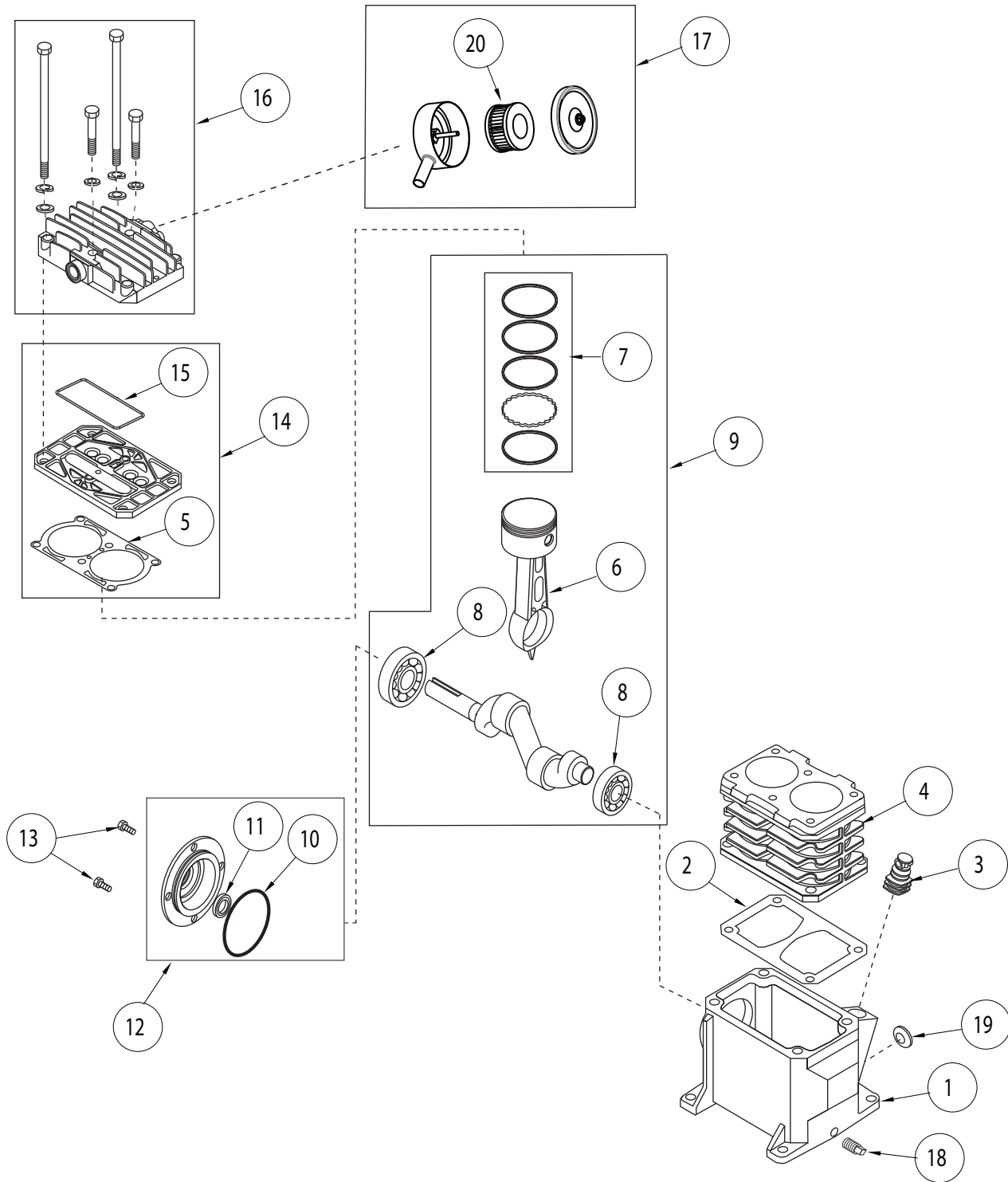

**For Repair Parts, visit [www.fscurtis.com](http://www.fscurtis.com) to find your local distributor**

**24 hours a day – 365 days a year**

Please provide following information:

- Model number
- Serial number (if any)
- Part description and number as shown in parts list

REPAIR PARTS LIST FOR FC479

Ref. No.	Description	Part Number:	Qty.
1	CRANKCASE	--	1
2	CRANKCASE GASKET	■	1
3	BREATHER	FCT2-BR	1
4	CYLINDER	--	1
5	CYLINDER GASKET	■	1
6	CONNECTING ROD AND PISTON ASSEMBLY	--	2
7	PISTON RING SET	--	2
8	BALL BEARING	--	2
9	CRANKSHAFT, BEARINGS, RODS, PISTON ASSEMBLY	FSK-C47DK	1
10	O-RING	■	1
11	OIL SEAL	--	1
12	BEARING CAP ASSEMBLY	--	1
13	M6 X 10 MM SCREW	†	4
14	VALVE PLATE ASSEMBLY	FSK-C47VK	1
15	VALVE PLATE MOLDED SEAL	■	1
16	CYLINDER HEAD AND FASTENERS	--	1
17	AIR FILTER ASSEMBLY	FCTHE-9AFA	1
18	1/8 IN.-27 OIL DRAIN PLUG	--	1
19	SIGHT GLASS	FCT02SG	1
20	AIR FILTER ELEMENT	FCTHE-9AFE	1
<b>REPAIR PARTS KITS</b>			
■	GASKET KIT	FSK-C47GK	
--	NOT AVAILABLE		
†	AVAILABLE AT LOCAL HARDWARE STORE		

GETTING STARTED

SAFETY / SPECIFICATIONS

ASSEMBLY / INSTALLATION

OPERATION

TROUBLESHOOTING

MAINTENANCE / REPAIR



**Reminder:** *Keep your dated proof of purchase for warranty purposes! Attach it to this manual or file it for safekeeping.*

## **LIMITED WARRANTY**

1. **DURATION:** The compressor pump and air receiver is warranted for one year from the date of purchase by the original purchaser. The balance of the compressor package is warranted for one year from the date of purchase by the original purchaser.
2. **WHO GIVES THIS WARRANTY (WARRANTOR):** FS-CURTIS, CURTIS-TOLEDO, INC. 1905 Kienlen Avenue, St Louis, Missouri 63133. Visit [www.fscurtis.com](http://www.fscurtis.com)
3. **WHO RECEIVES THIS WARRANTY (PURCHASER):** The original purchaser (other than for purposes of resale) of the FS-CURTIS, CURTIS-TOLEDO, INC air compressor.
4. **WHAT PRODUCTS ARE COVERED BY THIS WARRANTY:** FS-CURTIS, CURTIS-TOLEDO, INC FCTHEC47H9X-AXX1XX air compressor.
5. **WHAT IS COVERED UNDER THIS WARRANTY:** Parts and Labor to remedy defects in material and/or workmanship with the exceptions noted below.
6. **WHAT IS NOT COVERED UNDER THIS WARRANTY:**
  - A. Implied warranties, including those of merchantability and FITNESS FOR A PARTICULAR PURPOSE ARE LIMITED FROM THE DATE OF ORIGINAL PURCHASE AS STATED IN THE DURATION. Some States do not allow limitations on how long an implied warranty lasts, so the above limitations may not apply to you.
  - B. ANY INCIDENTAL, INDIRECT, OR CONSEQUENTIAL LOSS, DAMAGE, OR EXPENSE THAT MAY RESULT FROM ANY DEFECT, FAILURE, OR MALFUNCTION OF THE FS-CURTIS, CURTIS-TOLEDO, INC PRODUCT. Some States do not allow the exclusion or limitations of incidental or consequential damages, so the above limitation or exclusion may not apply to you.
  - C. Any failure due to:
    1. Accident or purchaser's abuse
    2. Improper installation
    3. Equipment that has not been operated or maintained in accordance with FS-CURTIS, CURTIS-TOLEDO, INC's instructions as detailed in the operating manual provided with the compressor.
    4. Equipment that has been repaired or modified without authorization from FS-CURTIS, CURTIS-TOLEDO, INC.
  - D. Pre-delivery service, i.e. assembly, oil or lubricants, and adjustment.
  - E. The effects of normal wear and tear.
  - F. Gasoline engines and components are expressly excluded from coverage under this limited warranty. The Purchaser must comply with the warranty given by the engine manufacturer which is supplied with the product.
  - G. Equipment that has been damaged in transit.
7. **RESPONSIBILITIES OF WARRANTOR UNDER THIS WARRANTY:** Repair or replace, at Warrantor's option, compressor or component which is defective, has malfunctioned and/or failed to conform within duration of the warranty period. Warranted repairs will be made at the Purchaser's location.
8. **RESPONSIBILITIES OF PURCHASER UNDER THIS WARRANTY:**
  - A. Provide dated proof of purchase and maintenance records.
  - B. Use reasonable care in the operation and maintenance of the products as described in the owner's manual(s).
  - C. Repairs requiring overtime, weekend rates, or anything beyond the standard manufacturer warranty repair labor reimbursement rate.
  - D. Time required for any security checks, safety training, or similar for service personnel to gain access to facility.
  - E. Location of unit must have adequate clearance for service personnel to perform repairs and easily accessible.
9. **WHEN WARRANTOR WILL PERFORM REPAIR OR REPLACEMENT UNDER THIS WARRANTY:** Repair or replacement will be scheduled and serviced according to the normal work flow at the servicing location, and depending on the availability of replacement parts.

This Limited Warranty applies in the U.S., Canada and Mexico only and gives you specific legal rights. You may also have other rights which vary from State to State or country to country.