

ARB AIR LOCKER *Air Operated Locking Differentials*

CKMA12 & CKMA24 Air Compressor

ITEM #	QTY	DESCRIPTION	PART #	NOTES
01	1	O-RING (BS010V75)	160242	5
02	1	MANIFOLD CAP (1/4" NPT)	320214	
03	1	PRESSURE SWITCH (1/4" NPT)	CO35	
04	2	O-RING (BS031N70)	160241	5
05	1	MANIFOLD TUBE	320215	
06	2	HEX BOLT (M6 x 60mm)	200703	
07	1	COMPRESSOR HEAD ASSEMBLY	320102	
08	1	SAFETY VALVE POPPET	320205	1
09	1	SAFETY VALVE SPRING	150115	1
10	1	SAFETY VALVE FITTING	320204	1
11	1	HEX BOLT (M6 x 125mm)	200704	
12	4	HEX BOLT (M6 x 12mm)	200702	
13	1	MANIFOLD SUPPORT BRACKET	320207	
14	#	AIR LOCKER CONTROL SOLENOID (12V)	180103	
15	#	NIPPLE (1/8" to 1/8" BSPT)	170501	
16	#	PUSH-IN FITTING (5mm to 1/8" BSPP)	170201	
17	3	O-RING (BS032S70)	160247	5
18	1	VALVE PLATE ASSEMBLY	320105	
19	1	BARREL	320201	
20	1	PISTON ASSEMBLY (SERVICE KIT)	320302	6
21	1	STICKER, CKM COMPRESSOR	210122	
22	1	MOUNT ASSEMBLY	320101	
23(a)	1	MOTOR ASSEMBLY (12V)	320104	2
23(b)	1	MOTOR ASSEMBLY (24V)	320106	2
24	4	HEX BOLT (M6 x 25mm)	200405	
*	4	CARRIAGE BOLT (M6 x 25mm)	6151082	
25	4	FLAT WASHER (M6)	200709	
26	1	BACKING PLATE	290603	
27	4	NYLON LOCK-NUT (M6)	6151223	
28	1	AXLE	320203	
29	1	CAP SCREW (M5 x 20mm)	200711	6,7,8
30	1	AIR FILTER FLANGE (1/4" NPT)	320212	
31	1	AIR FILTER BASE	320501B	3
32	1	AIR FILTER ELEMENT (DISK TYPE)	290503	3
33	1	AIR FILTER COVER	320501A	3
34	1	O-RING (BS029N70)	160250	5,8
*	1	WIRING LOOM (CKMA12 & CKMA24)	180409	4
*	1	RELAY (12V,40A)	CO42	
*	1	SWITCH (12V)	180209	
*	1	SWITCH COVER (COMPRESSOR)	180212	
*	1	SCOTCH LOCK ELEC. CONNECTOR (564)	CO45	
*	2	PLUG (1/8" BSPT)	170802	
*	2	EYE TERMINAL,10MM (YELLOW)	180702	
*	1	EYE TERMINAL,10MM (BLUE)	CO44	
*	1	INSTALLATION GUIDE,CKMA	2102MA12	
*	1	FUSE,40A,MAXI TYPE	180703	

Available separately or included with Air Locker kits.

* Not illustrated in exploded view.

Specs:

Voltage	12 Volts (CKMA12), 24 Volts (CKMA24)
Current Draw	No-Load 14.2A (CKMA12 only) Load 25.2A (CKMA12 only)
Air Flow	87.2L/min @ 0kPa [3.08CFM @ 0psi] 65.9L/min @ 200kPa [2.34CFM @ 29psi]
Total Weight	4.5kg [9.9lbs]
Size	145mm x 190mm x 98mm (H,L,W) [5.7" x 7.5" x 3.9"]
Manifold Port	1/4" NPT [Pressure Switch] x 1 1/8" BSPT [Solenoid nipple] x 2
Pressure Switch	Open 690kPa [100psi] Closed 490kPa [70psi]
Safety Valve	OPEN @ > ~1250Kpa [180 PSI]

Notes:

- 1 Comes pre-assembled with HEAD ASSY (07).
- 2 Motor voltage is the only difference between the CKMA12 and the CKMA24 compressors. CKM motors are serviceable. Contact ARB.
- 3 AIR FILTER BASE (31) & COVER (33) available only in AIR FILTER ASSY #320501 which also includes the element.
- 4 Wiring loom #180409 suits 12 & 24 volt systems. See full wiring diagram attached.
- 5 Complete set of O-ring seals is also available as O-ring Service Kit #320301.
- 6 PISTON ASSEMBLY (20) comes only as a service kit also containing the BARREL (19), AXLE (28), and CAP SCREW (29).
- 7 Thread lock must be applied to threads of CAP SCREW (29) and then torqued to 10 Nm [7.4ft-lb]. CAP SCREW (29) should never be re-used once it has been fully torqued once.
- 8 Pre June 2009 CKMA's used O-RING 160243 and CAP SCREW 200708 (M4 x 20mm torque to 6Nm [4.4ft-lb]).

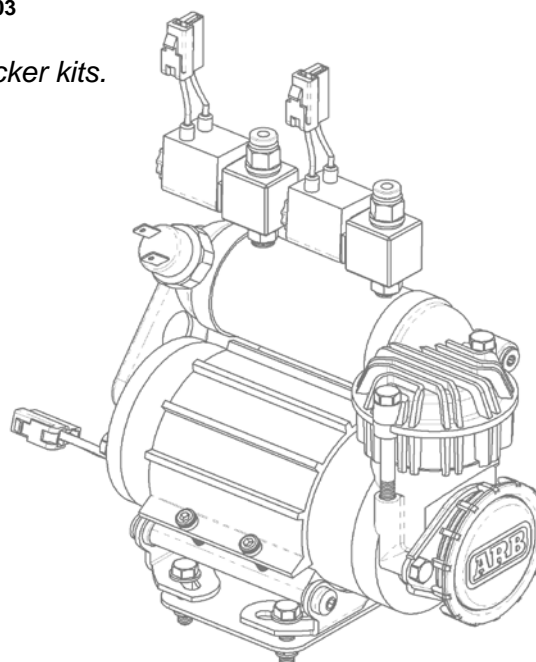

CKMA12 & CKMA24 Air Compressor – Exploded Parts Diagram

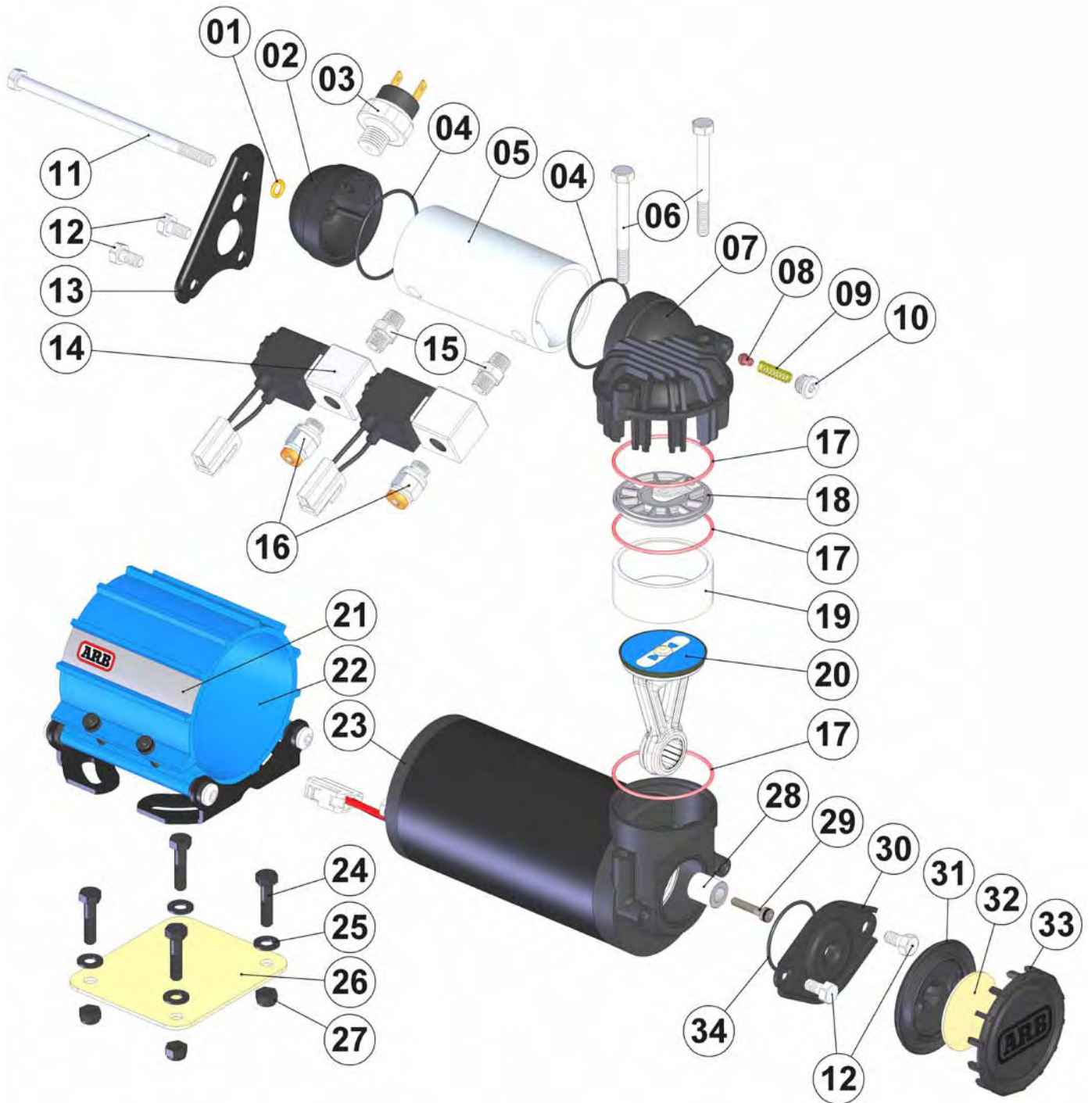

CKMA12 & CKMA24



ARB AIR LOCKER *Air Operated Locking Differentials*

CKMA12 & CKMA24 Air Compressor – Overall Sizes

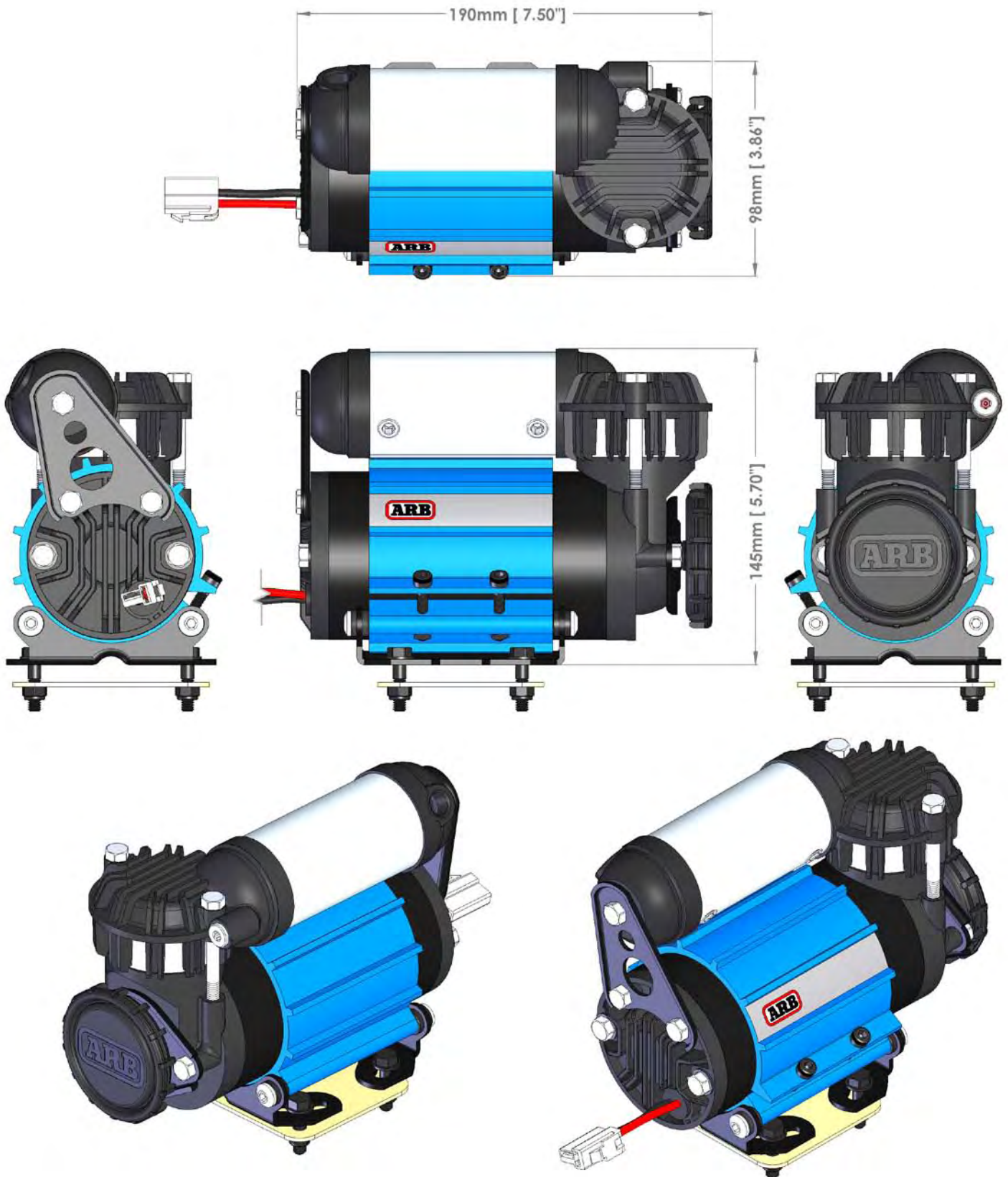

Description:

The ARB CKMA12 and CKMA24 compressor kits were designed specifically as a versatile, quick installing, compact yet high-flow air source to suit the ARB Air Locker, which also suits the harsh and demanding environment of the ARB Air Locker user.

Features:

- Available in 12V (CKMA12) or 24V (CKMA24) models.
- Ultra compact design makes it the highest flowing compressor in its class (voltage vs. size), and able to fit into tight areas where other high flowing compressors will not.
- Fully sealed components for moisture and dust resistance.
- Pressure switch controlled air manifold system specially designed to suit all ARB Air Locker equipped vehicles.
- Hard-anodized cylinder bore and PTFE (Teflon) impregnated carbon fibre piston seal for reduced friction and maximum trouble free life.
- Anodized mounting bracket dissipates motor heat and allows compressor to be repositioned 180°.
- Anti-vibration / sound deadening is integrated into the mount.
- Relocatable splash resistant air filter assembly for cleaner, cooler air supply and versatile waterproof air intake positioning.
- High density and high flow washable sintered bronze air filter element.
- Full wiring loom included for simplified installation and easy plug-in connectivity to Air Locker control solenoids.
- Heavy duty Maxi-Fuse equipped for professional in-line circuit protection.
- Motor is 100% ball bearing equipped, and features a unique linear brush pre-load system for extra long life, low heat and quiet operation throughout the life of the unit.
- Compressor piston is equipped with a German made high shock load rated cylindrical roller bearing.
- Constructed entirely of light weight, high strength, engineering grade materials, including military and aerospace standard components.
- Over-pressure safety valve equipped.
- Motor has internal thermal protection against extreme temperature damage.
- *Motor has integrated EMC noise suppression to protect sensitive auto electronic systems.

Kit Includes:

- Fully assembled and tested air compressor (12V or 24V).
- Complete wiring loom w/ Air Locker solenoid plug-in contacts.
- OEM quality IP54 rated compressor isolating dash switch.
- Air Locker supply rated pressure switch (490-690 KPa [70-100 PSI]).
- Relocatable splash resistant air filter with washable high-flow sintered bronze filter cartridge.
- Mounting hardware with reinforcing backing plate.
- Comprehensive photo illustrated installation guide.

* 12V Model is certified compliant to EN 55014.1 (AS/NZS CISPR 14.1) and meets or surpasses the following Australian and European directives.

 N17876  - 2004/108/EC – EMC directive

ARB Part # 180409 Air Compressor Loom – Wiring Diagram

