

# ARB AIR LOCKER *Air Operated Locking Differentials*

## **CKMP12** High Output Air Supply

ITEM #	QTY	DESCRIPTION	PART #	NOTES
01	1	SAFETY VALVE FITTING	320204	1
02	1	SAFETY VALVE SPRING	150115	1
03	1	SAFETY VALVE POPPET	320205	1
04	1	HEAD ASSEMBLY	320102	1
05	2	BOLT (M6 x 60mm)	200703	
06	2	O-RING (BS031N70)	160241	2
07	1	MANIFOLD TUBE (1/4" NPT)	320224	
08	1	HOSE COUPLING (US STD FEMALE)	171402	
09	1	MANIFOLD CAP (1/4" NPT)	320214	
10	1	PRESSURE SWITCH (1/4" NPT)	CO35	
11	1	BOLT (M6 x 60mm)	200703	
12	1	O-RING (BS010V75)	160242	2
13	1	FLAT WASHER	6151046	
14	4	RIVET (3/16" x 1/2")	6602003	
15	1	BOLT (M6 x 20mm)	6151213	
16	1	MOUNTING BRACKET	320223	
17	1	SWITCH (12V)	180209	
	1	SWITCH COVER ('ARB Compressor')	180212	
18	4	CAP SCREW (M5 x 10mm)	200710	
19	1	NYLON LOCK-NUT (M6)	6151223	
20	1	RELAY (12V,40A)	CO42	
21	1	MOUNT BODY ASSEMBLY	320101	
22	3	O-RING (BS032S70)	160247	2
23	1	VALVE PLATE ASSEMBLY	320105	
24	1	BARREL	320201	
25	1	PISTON ASSEMBLY (SERVICE KIT)	320302	3
26	1	AIR FILTER COVER	320501A	4
27	1	AIR FILTER ELEMENT (DISK TYPE)	290503	4
28	1	AIR FILTER BASE	320501B	4
29	2	BOLT (M6 x 12mm)	200702	
30	1	AIR FILTER FLANGE (1/4" NPT)	320212	
31	1	O-RING (BS029N70)	160250	2,6
32	1	CAP SCREW (M5 x 20mm)	200711	3,5,6
33	1	AXLE	320203	3
34	1	MOTOR ASSEMBLY (12V)	320104	
*	1	CARRY CASE	270103	
*	1	INFLATION ACCESSORY KIT (US STD)	171303	
*	1	HOSE ASSEMBLY (US STD)	171301	
*	1	WIRING LOOM (CKMP12)	180410	

\* Not illustrated in exploded view.

## Specs:

Voltage	12 Volts
Current Draw	No-Load 13A Load 23A
Air Flow	75.1L/min @ 0kPa [2.65CFM @ 0psi] 61.6L/min @ 200kPa [2.18CFM @ 29psi]
Total Weight	6.5kg [14.3lbs]
Size	208mm x 440mm x 238mm (H,L,W) [8.19" x 17.32" x 9.37"]
Manifold Port	1/4" NPT [Pressure Switch] x 1
Pressure Switch	Open 690kPa [100psi] Closed 490kPa [70psi]
Safety Valve	OPEN @ > -1250Kpa [180 PSI]

## Notes:

- HEAD ASSY (04) comes pre-assembled with safety valve.  
Motor voltage is the only difference between
- Complete set of O-ring seals is also available as O-ring Service Kit #320301.
- PISTON ASSEMBLY (25) comes only as a service kit also containing the BARREL (24), AXLE (33), and CAP SCREW (32).
- AIR FILTER BASE (31) & COVER (33) available only in AIR FILTER ASSY #320501 which also includes the element.
- Thread lock must be applied to threads of CAP SCREW (32) and then torqued to 10 Nm [7.4 ft-lb]. CAP SCREW (32) should never be re-used once it has been fully torqued once.
- Pre June 2009 CKMP's used O-RING 160243 and CAP SCREW 200708 (M4 x 20mm torque to 6Nm [4.4ft-lb]).

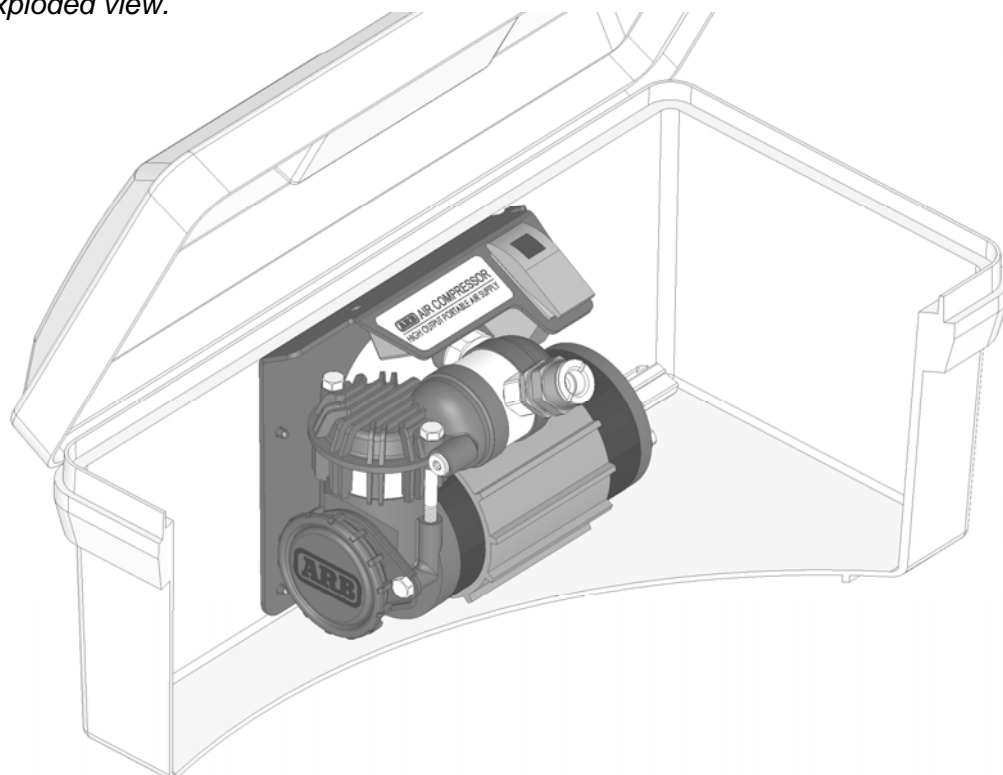

**CKMP12** High Output Air Supply – Exploded Parts Diagram

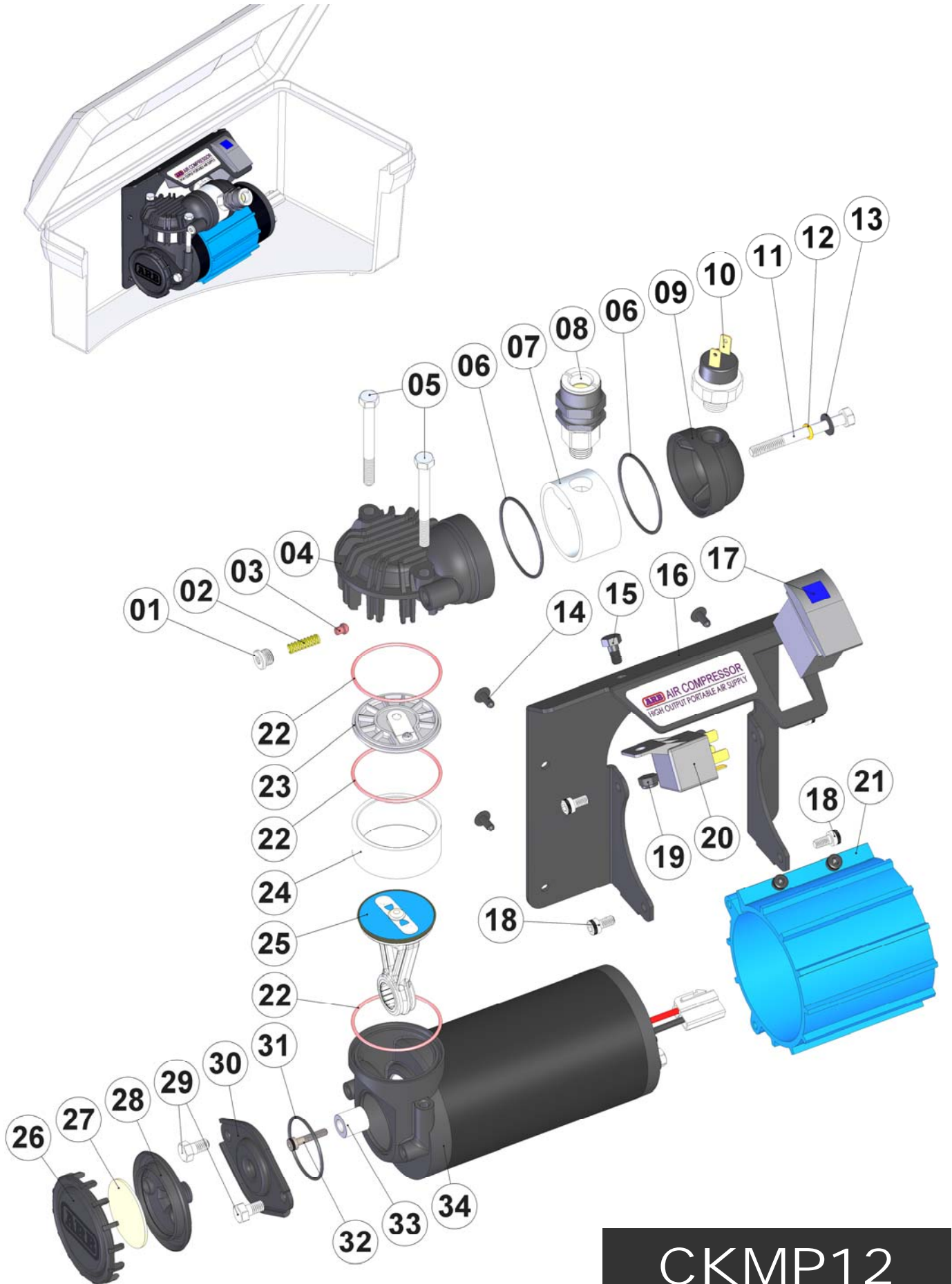

**CKMP12**



**CKMP12**

High Output Air Supply – Detailed Specifications

GENERAL SPECS		METRIC		IMPERIAL	
SUPPLY VOLTAGE		12	Volts DC	12	Volts DC
MAX CURRENT DRAW		32	Amps @ 690 KPa	32	Amps @ 100 PSI
FUSE RATING (Maxi-Blade type)		40	Amps	40	Amps
RELAY RATING		40	Amps	40	Amps
WEIGHT (total kit)		6.5	Kgs	14.3	Lbs
DIMENSIONS	-LENGTH	440	mm	17.32	inches
	-WIDTH	238	mm	9.37	inches
	-HEIGHT	208	mm	8.19	inches
DUTY CYCLE @ 22°C [72°F]		50	%	30	mins. per hour
PRESSURE SWITCH CLOSED		< 520	KPa	< 75	PSI
PRESSURE SWITCH OPEN		> 725	KPa	> 105	PSI
SAFETY VALVE PRESSURE		> 1035	KPa	> 150	PSI
MOTOR THERMAL CUT-OUT		115	degrees C	239	degrees F
MAX. AMBIENT TEMPERATURE		100	degrees C	212	degrees F

NO LOAD SPECS		METRIC @ 0 KPa		IMPERIAL @ 0 PSI	
CURRENT DRAW		13	Amps	13	Amps
AIR FLOW RATE		75.1	L/min.	2.65	CFM

SPECS @ TYRE PRESSURE		METRIC @ 200 KPa		IMPERIAL @ 29 PSI	
CURRENT DRAW		22.9	Amps	22.9	Amps
AIR FLOW RATE		61.6	L/min.	2.18	CFM

EXTERNAL CONNECTIONS SPECS	
AIR INTAKE THREAD (female)	1/4-18 NPSC (parallel pipe thread)
AIR FILTER THREAD (male)	1/4-18 NPT (tapered pipe thread)
PRESSURE SWITCH THREAD	1/4-18 NPT (tapered pipe thread)
SAFETY VALVE PORT THREAD	1/8 BSPP (parallel pipe thread)
MANIFOLD PORT THREAD	1/4-18 NPT (tapered pipe thread)
AIR COUPLING FITTING TYPE (international equivalent standards)	'US Industrial Standard' ISO 6150 B Rectus series 23/24/1400 Tema series 1400 Legris series 23 DYNAQUIP D3 CEJN 310 US.MIL.C 4109 Norma / AFNOR: NF.E49.053 Parker series 30-¼" and 20-¼" Aignep 220 Hansen series 3000 Norgren series 237 Gromelle series 600

**WARRANTY**

This ARB Air Compressor is designed to provide many years of trouble free recreational use, and is warranted to be free from manufacturing defects for two (2) years from the date of purchase.

**NOTE :** The specifications above were recorded under laboratory conditions @ 22°C [72°F].



## Description:

---

The ARB CKMP series portable air compressor is a world class recreational product designed and built to commercial / industrial / military standards for the user who values dependability as much as performance.

## Features:

---

- Ultra compact design makes this the highest flowing portable compressor in its class.
- Constructed entirely of light weight, high strength engineering grade materials, including military and aerospace standard components.
- Fully sealed components for moisture and dust resistance.
- Motor is 100% ball bearing equipped, and features a unique linear brush pre-load system for extra long life, low heat and quiet operation throughout the life of the unit.
- Motor is thermal cut-out protected against damage caused by extreme temperature use.
- Pressure switch and 40 amp automotive relay equipped electrical system prevents run-on when not filling, or any damage to compressor or hoses as a result of the pressure generated from a kinked air line.
- Illuminated isolating switch is easy to see at night, and protects the user from hazardous sparking when connecting the alligator clips to the battery terminals.
- Heavy duty Maxi-Fuse equipped power leads for professional in-line circuit protection.
- Hard-anodized cylinder bore and PTFE (Teflon) impregnated carbon fiber piston seal for reduced friction and maximum trouble free life.
- Compressor piston is equipped with a German made high shock rated roller bearing.
- High density and high flow washable sintered bronze air filter element.
- Over-pressure safety valve equipped as a back-up protection from either pressure switch failure, thermal over pressure generated in a hot vehicle (i.e., no need to drain pressure when finished use.), or accidental connection to an external high pressure source.

## Kit Includes:

---

- Fully assembled and performance tested air compressor mounted into a quality tradesman grade hard case.
- OEM quality illuminated compressor isolating switch.
- High quality wiring loom with automotive grade alligator clamp type battery contacts, and a pressure switch driven automotive relay control circuit.
- Splash resistant air filter with washable high-flow sintered bronze filter cartridge.
- 6 meter [20 ft] long high quality abrasion and heat resistant air hose with male to female couplings.
- Hose couplings are specially designed corrosion resistant, one-handed (push-lock) quick connect type to suit US industrial standard air fittings (Ref: compatible types Section 1.3).
- Inflation accessories kit including high-flow tyre filler attachment (US industrial standard) with integral stop-valve, a Schrader valve to US industrial standard adaptor, and extra nozzle attachments for inflating items such as sports balls, air mattresses, etc.

## Optional Accessories:

---

- Pump-up hose extension (part #171301) – a male to female coupling equipped air hose to reach 6m [20 ft] further. (same as the hose included with CKMP12)