

INSTRUCTION MANUAL

Air Supply Requirements

1. Supply tool with 90 psig (6.2 bar) of clean, dry air. Higher pressure drastically reduces tool life.
2. Connect tool to air line using pipe, hose and fitting sizes shown in the diagram on page 12.

Lubrication

Use an air line lubricator with SAE #10 oil, adjusted to two drops per minute. If an air line lubricator cannot be used, add air motor oil to the inlet once a day.

Noise & Vibration Declaration*

1. Sound pressure level 99 dB(A) in accordance with Pneuop 8N-1. For sound power, add 10 dB(A). (CP789HR)
Vibration value 2.5 m/s², re. ISO 8662-1. (CP789HR)
2. Sound pressure level 101 dB(A) in accordance with Pneuop 8N-1. For sound power, add 10 dB(A). (CP789R-26)
Vibration value 2.5 m/s², re. ISO 8662-1. (CP789R-26)
3. Sound pressure level 104 dB(A) in accordance with Pneuop 8N-1. For sound power, add 10 dB(A). (CP789R-42)
Vibration value 2.5 m/s², re. ISO 8662-1. (CP789R-42)

Maintenance

1. Disassemble and inspect air motor every three months if the tool is used every day. Replace damaged or worn parts.
2. High wear parts are underlined in the parts list.

*These declared values were obtained by laboratory type testing in compliance with the stated standards and are not adequate for use in risk assessments. Values measured in individual work places may be higher than the declared values. The actual exposure values and risk of harm experienced by an individual user are unique and depend upon the way the user works, the workpiece and the workstation design, as well as upon the exposure time and the physical condition of the user. We, Chicago Pneumatic, cannot be held liable for the consequences of using the declared values, instead of values reflecting the actual exposure, in an individual risk assessment in a work place situation over which we have no control.

EC DECLARATION OF CONFORMITY

We, Chicago Pneumatic Tool Company, 1800 Overview Drive, Rock Hill, SC 29730 USA, declare under our sole responsibility that the product to which this declaration relates, is in conformity with the requirements of the Council Directive of June 1989 on the approximation of the laws of the Member States relating to machinery (89/392/EEC).

Machine Name CP789R Series 3/8" & 1/2" Air Drill
Machine Type Power tool equipped with 3/8" (10 mm) and 1/2" (13 mm) drill chuck for use with various drill bits for drilling holes - No other use is permitted

Serial No. Tools with No. 98273A or higher

Technical Data

3/8" (10 mm) & 1/2" (13 mm) drill chuck
Free speed CP789HR (500RPM), CP789R-26 (2600 RPM), CP789R-42 (4200 RPM)
Air pressure 90 psi (6.2 bar)
Air consumption 30 cfm

National Standards Applied ISO 8662-1, Pneuop 8N-1

Name and Position of Issuer W. A. LeNeuve, President, Chicago Pneumatic Tool Company

Signature of Issuer 

Place and Date of Issue Rock Hill, SC 29730 USA, September 30, 1998

MANUFACTURER'S LIMITED WARRANTY

Limited Warranty: The "Products" of the Chicago Pneumatic Tool Company ("CP") are warranted to be free from defects in material and workmanship for one year from the date of purchase. This Warranty applies only to Products purchased new from CP or its authorized dealers. Of course, this Warranty does not apply to products which have been abused, misused, modified, or repaired by someone other than CP or its Authorized Service Representatives. If a CP Product proves defective in material or workmanship within one year after purchase, return it to any CP Factory Service Center or Authorized Service Center for CP tools; transportation prepaid, enclosing your name and address, adequate proof of date of purchase, and a short description of the defect. CP will, at its option, repair or replace defective Products free of charge. Repairs or replacements are warranted as described above for the remainder of the original warranty period. CP's sole liability and your exclusive remedy under this Warranty is limited to repair or replacement of the defective Product. **(There Are No Other Warranties Expressed Or Implied And CP Shall Not Be Liable For Incidental, Consequential, Or Special Damages, Or Any Other Damages, Costs Or Expenses Excepting Only The Cost Or Expense Of Repair Or Replacement As Described Above.)**

© Copyright 2004, Chicago Pneumatic, 1800 Overview Drive, Rock Hill, SC 29730 USA

All rights reserved. Any unauthorized use or copying of the contents or part thereof is prohibited. This applies in particular to trademarks, model denominations, part numbers and drawings.

Use only authorized parts. Any damage or malfunction caused by the use of unauthorized parts is not covered by Warranty or Product Liability.



WARNING

To reduce risk of injury, everyone using, installing, repairing, maintaining, changing accessories on, or working near this tool must read and understand these instructions before performing any such task.

The goal of Chicago Pneumatic is to produce tools that help you work safely and efficiently. The most important safety device for this or any tool is YOU. Your care and good judgment are the best protection against injury. All possible hazards cannot be covered here, but we have tried to highlight some of the important ones.

For Additional Safety Information Consult:

- ▲ Your employer, union and/or trade association.
- ▲ US Department of Labor (OSHA); www.osha.gov; Council of the European Communities europe.osha.eu.int
- ▲ "Safety Code for Portable Air Tools" (B186.1) available from: www.ansi.org
- ▲ "Safety Requirements for Hand-Held Non-Electric Power Tools" available from: European Committee for Standardization, www.cenorm.be

Air Supply And Connection Hazards

- ▲ Air under pressure can cause severe injury.
- ▲ Always shut off air supply, drain hose of air pressure and disconnect tool from air supply when not in use, before changing accessories or when making repairs.
- ▲ Never direct air at yourself or anyone else.
- ▲ Whipping hoses can cause serious injury. Always check for damaged or loose hoses and fittings.
- ▲ Do not use quick disconnect couplings at tool. See instructions for correct setup.
- ▲ Whenever universal twist couplings are used, lock pins must be installed.
- ▲ Do not exceed maximum air pressure of 90 psi/6.2 bar or as stated on tool nameplate.

Projectile Hazards

- ▲ Always wear impact-resistant eye and face protection when involved with or near the operation, repair or maintenance of the tool or changing accessories on the tool.
- ▲ Be sure all others in the area are wearing impact-resistant eye and face protection.
- ▲ Even small projectiles can injure eyes and cause blindness.

Entanglement Hazards

- ▲ Keep away from rotating bit and chuck.
- ▲ Do not wear jewelry or loose clothing.
- ▲ You can be cut or burned if you come in contact with the drill bit, chips or work surface.
- ▲ Use intermittent drill pressure to avoid long shaved chips.

SAFETY INSTRUCTIONS

- ▲ Scalping can occur if hair is not kept away from tool and accessories.
- ▲ Choking can occur if neckwear is not kept away from tool and accessories.

Bit Binding Hazards

- ▲ The drill bit can suddenly bind and cause the work piece or tool to rotate, causing arm and shoulder injuries.
- ▲ Enough torque is generated to cause falls.
- ▲ Always use sharp bits.
- ▲ Reduce downward pressure at breakthrough.
- ▲ ANSI recommends the use of a support handle on drills with a chuck capacity larger than 3/8 in. or 10 mm.
- ▲ Operators and maintenance personnel must be physically able to handle the bulk, weight and power of this tool.

Workplace Hazards

- ▲ Slip/Trip/Fall is a major cause of serious injury or death. Be aware of excess hoses left on the walking or work surface.
- ▲ Maintain a balanced body position and secure footing.
- ▲ High sound levels can cause permanent hearing loss. Use hearing protection as recommended by your employer or OSHA regulation (see 29 CFR part 1910).
- ▲ Repetitive work motions, awkward positions and exposure to vibration can be harmful to hands and arms. If numbness, tingling, pain or whitening of the skin occurs, stop using tool and consult a physician.
- ▲ Avoid inhaling dust or handling debris from the work process which can be harmful to your health. Use dust extraction and wear respiratory protective equipment when working with materials which produce airborne particles.
- ▲ Proceed with care in unfamiliar surroundings. Hidden hazards may exist, such as drilling into electric or other utility lines.
- ▲ This tool is not intended for use in an explosive atmosphere and is not insulated for contact with electric power sources.
- ▲ Some dust created by power sanding, sawing, grinding, drilling and other construction activities contains chemicals known to the State of California to cause cancer and birth defects or other reproductive harm. Some examples of these chemicals are:
 - Lead from lead based paints
 - Crystalline silica bricks and cement and other masonry products
 - And Arsenic and chromium from chemically-treated rubber
- ▲ Your risk from these exposures varies, depending on how often you do this type of work. To reduce your exposure to these chemicals: work in a well ventilated area, and work with approved safety equipment, such as dust masks that are specially designed to filter out microscopic particles.
- ▲ For professional use only.

CP789R Series

Air Drill

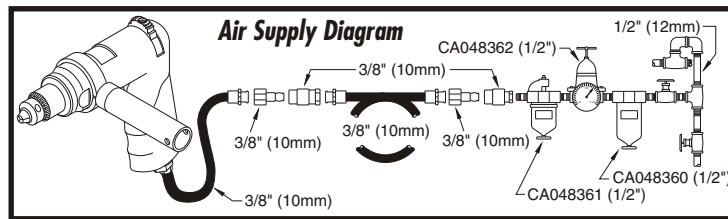
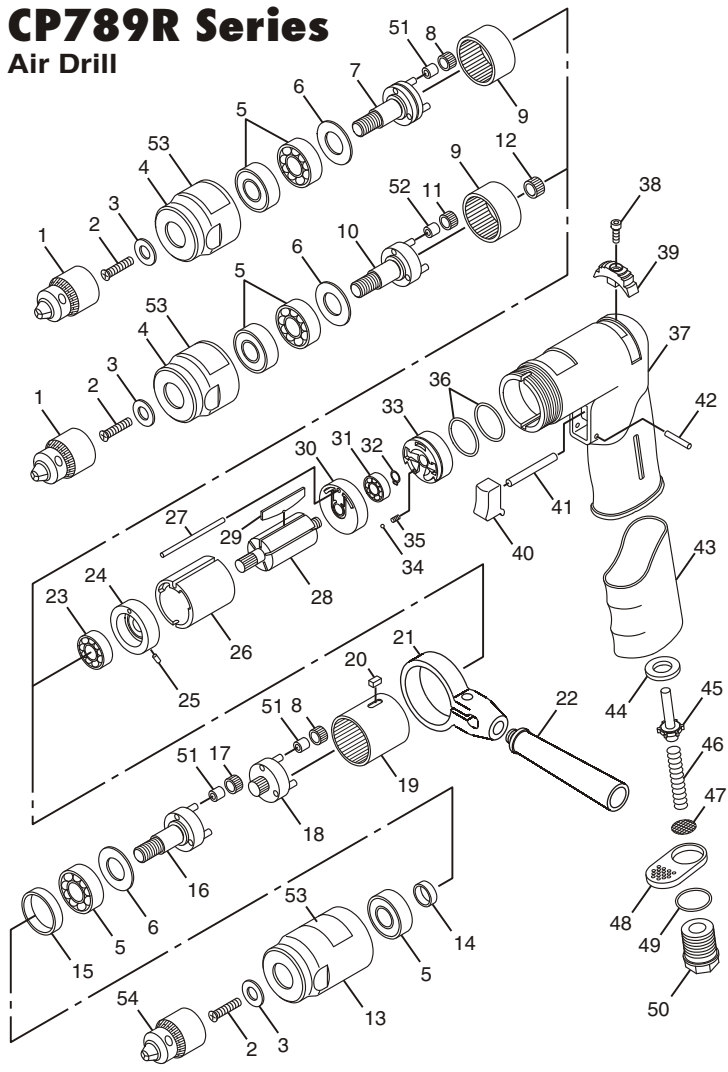

Index No.	Part No.	Description	No. Req'd.
1	C140187	Chuck 3/8" (Includes Key)	1
2	CA146086	Screw-Chuck RH Thread	1
	CA157803	Torx Screw LH Thread 789HR (Model B)	1
3	CA146088	Spacer-Chuck	1
4	CA155982	Housing-Gear (2600, 4200)	1
5	S014490	Bearing-Ball	2
6	CA146091	Washer	1
7	CA155983	Shaft-Spindle (2600)	1
8	CA156616	Gear-Idler (500, 2600)	3
9	CA155520	Gear-Internal (2600, 4200)	1
10	CA155984	Shaft-Spindle (4200)	1
11	CA156615	Gear-Idler (4200)	3
12	CA156618	Gear-Slipon (4200)	1
13	CA155978	Housing-Gear (500)	1
14	CA146117	Collar-Inner (500)	1
15	CA146116	Collar-Outer (500)	1
16	CA155979	Shaft-Spindle (500)(Model B)	1
17	CA156617	Gear-Idler (500)	3
18	CA155981	Carrier (500)	1
19	CA155987	Gear-Internal (500)	1
20	CA156611	Key	1
21	CA146179	Ring-Clamp (500)	1
22	C136901	Handle-Support (500)	1
23	C087834	Bearing-Ball	1
24	CA155517	Plate-Front	1
25	KF125279	Pin-Roll 2.5 x 5 mm	1
26	CA146098	Liner	1
27	KF131295	Pin-Liner Dowel	1
28	CA155980	Rotor	1
29	CA145709	Blade Set-Rotor (5)	1
30	CA155518	Plate-Rear	1
31	CA155004	Bearing-Ball	1
32	KF137287	Ring-Retaining	1
33	CA155516	Valve-Reverse	1
34	S000821	Ball-Steel .125	1
35	CA156610	Spring-Compression	1
36	CA154998	O-Ring	2
37	CA155514	Housing-Motor	1
38	CA156612	Screw	1
39	CA155515	Button-Reverse	1
40	CA147017	Trigger	1
41	CA144831	Pin-Throttle	1
42	KF137213	Pin-Roll 2.5 - 20 mm	1
43	CA155521	Cover-Grip	1
44	C139037	Seat-Throttle	1
45	CA142460	Valve-Throttle	1
46	CA156613	Spring-Compression	1
47	CA059037	Strainer-Air	1
48	CA155522	Deflector	1
49	C052142	O-Ring (018)	1
50	C139035	Bushing-Inlet	1
51	KF125239	Bearing-Needle 4 mm (500, 2600)	3
52	CA156619	Bearing-Needle 3 mm (4200)	3
53	CA156018	Label-Warning	1
54	C142407	Chuck 1/2" (Includes Key 55)	1
55	C142385	Key-Chuck (not shown)	1

FOR DETAILED INFORMATION ABOUT CHICAGO PNEUMATIC AIR TOOLS AND EQUIPMENT CONTACT:

HEADQUARTERS LOCATION UNITED STATES

Chicago Pneumatic Tool Company
Automotive Division
1800 Overview Drive
Rock Hill, SC 29730
Telephone: 1-803-817-7000
1-800-367-2442 (USA only)
Fax: 1-800-228-9096

AUSTRALIA

Atlas Copco Tools Australia
3 Bessemer Street
Blacktown • Australia
Telephone: 02-621-9482
Fax: 02-671-5915

BELGIQUE

Chicago Pneumatic Rep. Office
Avenue Sluysmans 10-4030
Liege • Belgium
Tel/Fax: 04-343 8150

BRASIL

Chicago Pneumatic Brasil
Av. Mascote 159 V. Sta. Catarina
04363-000
Sao Paulo/SP • Brasil
Telephone: (011) 562-7314
Fax: (011) 563-9208

CANADA

Chicago Pneumatic Tool Co.
Automotive Division
1800 Overview Drive
Rock Hill, SC 29730
Telephone: 1-803-817-7000
Fax: 1-800-228-9096

CENTRAL AMERICA

Contact Chicago Pneumatic/USA
for names of CP Authorized
Distributors in this area

FRANCE

Espace Lumière
Bâtiment S
57, Boulevard de la République
78403 Chatou Cédex. France
Telephone: (0) 1 30 09 60 00
Fax: (0) 1 30 71 96 70

GERMANY

Desoutter GMBH
Vehicle Service
Edmund-Seng-strasse 3-5
D-63477 Maintal, Germany
Telephone: 49-0611-270120/22
Fax: 49-0611-270140

INDIA

Chicago Pneumatic Sales
Chemtex House, First Floor
Main Street
Hiranadani Gardens
Powai, Mumbai 400076, India
Telephone: (22)25704907
(22)25708984
Fax: (22)25705042

ITALY

Desoutter Italiana S.R.L.
Viale Della Repubblica, 65
20035 Lisson (Milano)

MEXICO

Chicago Pneumatic Tool
Company Mexico
San Francisco #223
Valle Dorado, Tlalpan
C.P. 54020 • Mexico
Telephone: 525-378-0754
Fax: 525-378-0753

SOUTH AFRICA

Chicago Pneumatic Tool
Company, S.A.
20 Anvil Road
PO Box 105
Isando 1600, Transvaal
South Africa
Telephone: 011-9746761
Fax: 011-974-2324

SOUTH AMERICA

Contact Chicago Pneumatic/USA
for names of CP Authorized
Distributors in this area

SOUTHEAST ASIA

Chicago Pneumatic Tool
Company Regional Office
P.O. Box 1516
Unit 2103 - Citimark
28 Yuen Shun Circuit
Shatin
New Territories, Hong Kong
Telephone: (852) 3570963
Fax: 852-763-1875

SPAIN

Desoutter S.A.
C. Serrano, 120
28006 Madrid, Spain
Telephone: 91 590 31 52
Fax: 91 590 31 61

SWEDEN

Chicago Pneumatic
Distributor Markets
Sickla Industriväg 7
S-131 34 Nacka • Sweden
Telephone: 46 8743 9329
Fax: 46-8743 9427

UNITED KINGDOM

Chicago Pneumatic
Tool Company, Ltd.
P.O. Box 241
Eaton Road
Hemel Hempstead, Herts HP2 7DR
England
Domestic: 01442-847703/06
Export: 01442-232420/17
Fax: 01442-2847723

Visit our website:
<http://www.cp.com>