



USER'S AND MAINTENANCE MANUAL

MOTOR COMPRESSOR

GP 75



Dear customer,

	USER'S AND MAINTENANCE MANUAL	Date:	25/02/2020
		Code	MAN GP75 ENG
Motocompressor : GP75		Revision	00

Thanks for having purchased this Rotair motor compressor, which is designed and manufactured in compliance with high standards, in order to ensure high quality performance, as well as easy use and installation.

For any information, you can contact our customer service at the following address:

ELGI PORTABLE COMPRESSORS

4610 Entrance Drive St A
Charlotte, NC 28273
704-523-4123

Portableservice@elgi.com

Portablesales@elgi.com

	USER'S AND MAINTENANCE MANUAL	Date:	25/02/2020
		Code	MAN GP75 ENG
Motocompressor : GP75		Revision	00

FOREWORD

These service instructions have been drafted to facilitate the knowledge of the machinery purchased and its modes of use.

In drafting them, we have intentionally omitted the technical in-depth description of some operations linked to the motor and the axle, since such information is contained in the user's and maintenance of the respective manufacturers.

The service instructions contain indications of utter importance concerning the safe appropriate and cost-effective operation of the machine.

The compliance with said operations helps prevent potentially hazardous situations, additional costs and loss of time, increasing at the same time its life-span.

The service instructions and safety measures reported in this manual must be complied with by the user of the machinery.

Besides the service instructions and the accident prevention prescriptions which apply in the countries and places of installation, all the more general rules of safety at the workplace must be complied with.

It is therefore recommended to carefully read the instructions reported in this manual.

This manual cannot be disclosed, duplicated or copied without the previous authorization by the Manufacturer. Any lack of compliance with the above shall be pursued under the Law, in particular if the illicit action involves advantage for competing companies.

TABLE OF CONTENTS

1	General	7
1.1	Definitions.....	7
1.1.1	Qualified personnel	7
1.1.2	Hazard.....	7
1.1.3	Hazardous area.....	7
1.1.4	Exposed person	7
1.1.5	Operator	7
1.1.6	Risk	7
1.1.7	Guard	7
1.1.8	Protection Equipment.....	7
1.1.9	Expected use.....	7
1.1.10	Reasonably expectable incorrect use	7
1.1.11	Component.....	7
1.1.12	Control Device.....	7
1.1.13	Safety interlock.....	8
1.1.14	Manufacturer	8
1.2	Machinery Identification	8
1.3	Harmonized technical standards.....	9
1.4	General description of the machinery	10
2	Technical characteristics of the machinery	11
2.1	General technical characteristics	11
2.2	Technical characteristics of the compressor.....	11
2.3	Technical characteristics of the engine	11
2.4	Technical characteristics of the electric battery	12
2.5	Service temperatures	12
3	Symbols and warnings	13
3.1	Hazards	13
3.2	Forbiddances.....	14
3.3	Obligations and notices	14
3.4	General notices	15
4	Use of the machinery	16
4.1	Use allowed.....	16
4.2	Use not allowed.....	16
4.3	Residual risk.....	16
5	Levels and qualifications of the personnel	17
6	Lifting instructions	17
6.1	Safety provisions concerning maintenance	18
7	Machinery components	19
7.1	Chassis and tow-bar – Figure 7-1 Part. A and F.....	20
7.2	Engine - Figure 7-1 Part.B	20
7.3	Compression unit and oil separator tank - Figure 7-1 Part.C and I	20
7.4	Battery - Figure 7-2 Part.D	20

7.5	Belts and pulley	20
7.6	Control devices and instruments.....	21
7.7	Fuel tank- Figure 7-2 Part.E	21
7.8	Cooling radiator- Figure 7-2 Part.M.....	21
8	Hydraulic and pneumatic systems	22
8.1	Pneumatic system	23
9	Provisions for the appropriate utilization of the motor compressor	24
9.1	Before starting-up.....	24
9.2	Machine start-up.....	24
9.3	During the working stage	25
9.4	Machine stopping	25
9.5	After machine stopping.....	25
10	Machine calibration and tuning.....	26
10.1	Maximum engine speed check.....	26
10.2	Final maximum pressure checking and calibration	26
10.3	Minimum pressure calibration and checking.....	27
10.4	Safety valve check	28
11	Maintenance program	29
11.1	Daily checks	29
11.2	Every three months	29
11.3	General maintenance program	30
12	Periodic Maintenance.....	31
12.1	Air filter check.....	31
12.2	Battery check.....	32
12.3	Cooling radiator cleaning	32
12.4	Oil recovery nozzle checking and cleaning	33
12.5	Fuel tank drainage.....	33
12.6	Compressor oil filter replacement	34
12.7	Compressor oil replacement	34
12.8	Checking of oil separator element.....	35
12.9	Instructions for oil separator element replacement	35
12.10	Control , tension and replacement of transmission belts	36
12.11	Transmission belt replacement	37
12.12	Values of tightening screws and bolts.....	38
13	Spare parts	38
14	Faults and troubleshooting	39
15	Disposal, elimination, disposal of the machine.....	40
15.1	Instructions for dismantling	40
16	Eliminating the machine	41
17	Waste management	41
18.1	Special waste	41
18.2	Toxic and hazardous waste	41
18.3	Temporary storage	41



**USER'S AND
MAINTENANCE
MANUAL**

Date: 25/02/2020

Code MAN GP75 ENG

Motocompressor : GP75

Revision 00

18.4 Features of the containers41
18.5 Registration requirements41

1 GENERAL

1.1 Definitions

The most significant definitions contained in this manual are reported hereinafter

1.1.1 QUALIFIED PERSONNEL

"Qualified personnel" are those personnel who are familiar with the rules for installation, assembly, repair and servicing of the machinery and who are provided with the specified technical qualification, such as e.g.: Technical training authorizing to operate in compliance with the safety standards as related to the hazards the presence of electric current, pressure circuits, etc. may involve.

Technical background or - in any case - specific training relevant to the user's and maintenance procedures of the machinery in safety conditions.

Training in the basic first-aid activities.

1.1.2 HAZARD

A potential source of injury or damage to health

1.1.3 HAZARDOUS AREA

Any area within and/or in proximity of machinery where the presence of a person constitutes a risk for the health and safety of said person.

1.1.4 EXPOSED PERSON

Any person being fully or partially in a hazardous area

1.1.5 OPERATOR

The person/people charged to install, operate, adjust, clean, repair or move a Machinery or perform its maintenance.

1.1.6 RISK

Combination of the likelihood and severity of an injury or damage to health which may arise in a hazardous situation.

1.1.7 GUARD

Part of the machinery utilized to ensure protection by means of a material barrier.

1.1.8 PROTECTION EQUIPMENT

Device (different from a guard) which reduces the risk, by itself or associated to a guard.

1.1.9 EXPECTED USE

The use of the machinery in compliance with the user's information.

1.1.10 REASONABLY EXPECTABLE INCORRECT USE

The use of the machinery in a different way than the one indicated in the user's instructions, but which may derive from the easily expectable human behaviour.

1.1.11 COMPONENT

A constituent part of the electrical/pneumatic equipment, usually specified by its function, but used in various applications.

1.1.12 CONTROL DEVICE

A device introduced in a control circuit and used to control the operation of the system (e.g. position sensors,

	USER'S AND MAINTENANCE MANUAL	Date:	25/02/2020
		Code	MAN GP75 ENG
Motocompressor : GP75		Revision	00

manual control switches, relays, electro-magnetic control valves).

1.1.13 SAFETY INTERLOCK

Mechanical, electrical or other device whose purpose is to prevent the parts of the machinery from operating in specified conditions (generally, until the guard is closed)

1.1.14 MANUFACTURER

Physical or legal person who designed and/or develops machinery or partly-completed machinery which is subject of this directive and who is liable for the compliance of the machinery or partly-completed machinery with this directive as related to its marketing with his/her name or brand, or for personal use. In absence of a Manufacturer as defined above, the Manufacturer shall be considered the physical or juridical person who markets or puts into service machinery or partly-completed machinery.

1.2 Machinery Identification

The CE identification nameplate is attached on the motor compressor chassis.

Such nameplate reports the Manufacturer's data, the denomination of the machinery, the code and year of manufacturing.

For any requests for spare parts or actions by our technicians, please refer to the data reported in the nameplate; in particular the code number of the machinery must always be mentioned.

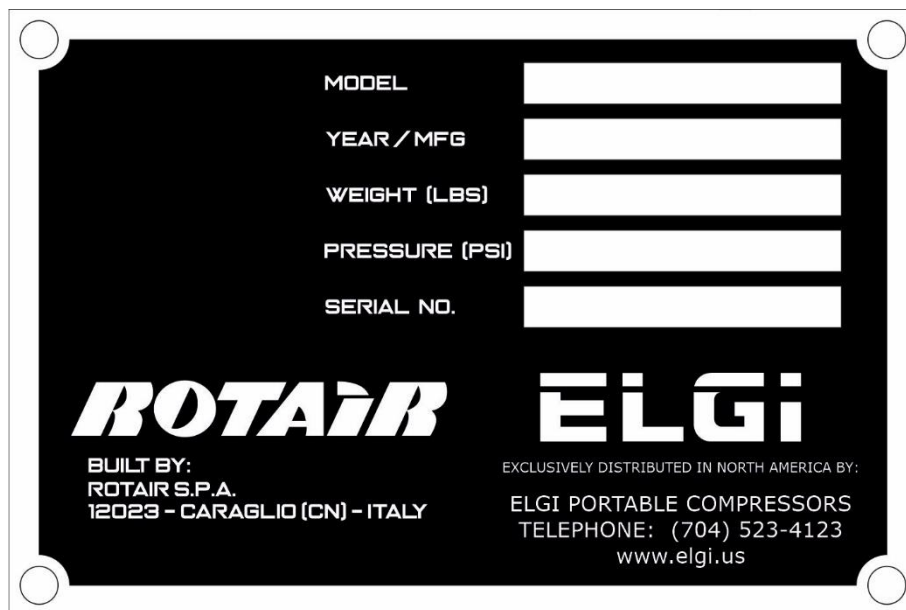



Figure 1.2-1 - Nameplate of motocompressor GP 75

	USER'S AND MAINTENANCE MANUAL	Date:	25/02/2020
		Code	MAN GP75 ENG
Motocompressor : GP75		Revision	00

1.3 Harmonized technical standards

The machinery has been designed and developed in compliance with the provisions contained in the technical standards reported herein under:

UNI EN ISO 12100	Safety of machinery -General design principles - Risk assessment and risk reduction.
UNI EN ISO 13857	Safety of machinery– Safety distances to prevent from reaching the hazardous areas with the upper or lower limbs.
UNI EN ISO 13850	Safety of machinery - Emergency stop system, functional aspects
CEI EN 62061	Safety of machinery - Functional safety of the programmable electrical and electronic control systems as related to safety
CEI EN 60204-1	Safety of machinery - Electrical equipment of the machineries. Part I: General rules.
UNI EN 983	Safety of machinery. Safety requirements relevant to systems and related components for hydraulic and pneumatic transmission. Pneumatics.
UNI EN 349	Safety of machinery - Minimum openings to prevent the crushing of parts of the human body.
D. LGS. January 27th 2010 no.17	Implementation of Directive 2006/42/CE relevant to machinery, which modifies directive 95/16/CE relevant to elevators.
UNI EN ISO 14121-1	Safety of machinery - Risk assessment. General principles
UNI EN ISO -TR 14121-2	Safety of machinery - Examples

	Machine directive 2006/42/CE.
<p>Article 7. Presumption of conformity and harmonized standards</p> <p>1. The Member States deem that the machinery provided with the “CE” marking and accompanied by the CE declaration of conformity, whose elements are provided for in Annex II, Part 1, Section A, comply with the provisions of this directive.</p> <p>2. The machinery manufactured in compliance with an authorized standard, whose reference has been published on the Official Journal of the European Union is assumed to be compliant with the essential health and safety requirements covered by such harmonized standard.</p> <p>3. The Commission published the references of the harmonized standards in the Official Journal of the European Union.</p> <p>4. The Member States shall take the appropriate measures to allow the social partners influencing - at national level - the development and control process of the harmonized standards.</p>	

	USER'S AND MAINTENANCE MANUAL	Date:	25/02/2020
		Code	MAN GP75 ENG
Motocompressor : GP75		Revision	00

1.4 General description of the machinery

The machinery described in this manual is motor compressor GP75.

The motor compressor is a piece of machinery with the capacity of generating a given quantity of compressed air in l/min / CFM by using a diesel engine as primary energy.

The pneumatic energy finds applications in different fields of use, where "pneumatic" operation tools, accessories and equipment are utilized. For instance: demolition hammers, drilling hammers, vibrators, drilling machines, rammers, coating machines, etc.

Each of these tools/-accessories has its own consumption of compressed air, expressed in liters per minute. The optimum coupling between the compressor and the tool is achieved when the compressed air consumption does not exceed 85% of the air generated by the compressor (furthermore, it must be taken into consideration that the quantity of compressed air required by the tool shall increase in time, proportionally to the wear of the tool itself).

The correct compressor-tool coupling ratio allows the machinery operating in optimum conditions, as appropriate to ensure long life-span at the highest performance.

An oversized tool - besides creating unfavourable conditions for the appropriate operation of the machinery - shall not develop full performance, since it cannot resort to the required quantity of compressed air.

This machinery has been designed to work at ambient temperature ranging from -10 and +40°C.

2 TECHNICAL CHARACTERISTICS OF THE MACHINERY

The general technical characteristics of the machinery are reported hereinafter.

MODELS	ENGINE	MAX. ROTATION SPEED	WORKING PRESSURE	AIR YIELD
GP 75	HONDA GX690 – 22,5 HP	3400 rpm	6 bar - 87 psi	75 CFM

2.1 General technical characteristics

DESCRIPTION	TECHNICAL VALUES AND DATA
Length	44.29 "
Width	30.5 "
Height (with hood closed)	39.94 "
Weight in operational conditions (approximate)	507 lbs
Compression system	Screw single-stage
Fuel tank capacity	5 gal
Tire data	3.00 R4"

2.2 Technical characteristics of the compressor

DESCRIPTION	TECHNICAL VALUES AND DATA
Minimum pressure	73 Psi
Lubrication system capacity	0.53 Gal
Cooling typology	Hydraulic oil (*)

(*) We recommend TOTAL/ERG COMPRESSOR 46.

2.3 Technical characteristics of the engine

DESCRIPTION	TECHNICAL VALUES AND DATA
Engine brand	HONDA
Type	GX 690
Number of cylinders	2
Fuel	Petrol
Cooling	Air
Power potential	16,5 Kw(22,5HP)
Max. rotation speed	3400 r.p.m.
Emissions	EURO 2
Engine oil tank capacity	0,45 gal

Motocompressor : GP75**2.4 Technical characteristics of the electric battery**

DESCRIPTION	TECHNICAL VALUES AND DATA
Rated voltage	12 Vdc
Capacity	30 Ah
Discharge current	300 A

2.5 Service temperatures

DESCRIPTION	TECHNICAL VALUES AND DATA
Minimum ambient temperature limit	-10°C [14 ° F]
Maximum ambient temperature limit	+40° C [105°F]
Humidity limits	≤ 50% (a +40°C-105°F)
Altitude	1.000 m above sea level

3 SYMBOLS AND WARNINGS

The pictograms and main warning for the operators are reported herein under and indicated by the following denominations and symbols:

3.1 Hazards

**WARNING**

The pictogram calls the attention of specific provisions in order to prevent damage.

**WARNING FOR ELECTRICAL HAZARD**

The pictogram calls the attention of specific provisions in order to prevent damage.

**WARNING FOR CRUSHING HAZARD**

The pictogram calls the attention on a likely hazardous situation with risk of crushing the upper limbs.

**WARNING HAZARD OF ORGANS IN MOTION**

The pictogram calls the attention to the hazard of organs in motion.

**WARNING ON RISK OF SCALDING OR HAZARD DUE TO HIGH-TEMPERATURE ELEMENTS**

The pictogram calls the attention on the hazard of high-temperature elements and risk of scalding.



**WARNING:
OVERHANG
ING LOADS**

OVERHANGING LOAD WARNING

The pictogram calls the attention to the hazard due to the presence of overhanging loads

**WARNING OF THE PRESENCE OF PRESSURE VESSELS**

The pictogram calls the attention to the presence of pressure vessels.

3.2 Forbiddances

**FORBIDDANCE TO REMOVE THE PROTECTION EQUIPMENT AND THE GUARDS**

The pictogram calls the attention on the forbiddance to remove protection equipment such as fixed, movable, interlock guards or to tamper with photocells or photocell barriers.

**FORBIDDANCE TO PERFORM CLEANING OR MAINTENANCE WHEN THE MACHINERY IS IN MOTION**

The pictogram calls the attention on the forbiddance to perform cleaning or maintenance operations with organs in motion.

**FORBIDDANCE TO TRANSIT UNDER OVERHANGING LOADS**

The pictogram calls the attention on the forbiddance to transit under overhanging loads.

**FORBIDDANCE TO START THE MACHINERY WHEN THE HOOD IS OPEN**

3.3 Obligations and notices

**NOTICES**

This symbol recommends to consult the manual before undertaking a given action.

**OBLIGATIONS TO USE THE PPE (PERSONAL PROTECTION EQUIPMENT)**

The pictogram calls the attention on the obligation to use the personal protection equipment.

**NOTICES**

This symbol highlights that the description involves significant parts, since they may cause severe mechanical and electrical damage and malfunctions if the relevant standards are not complied with. It is recommended to comply with the information contained in this manual and with the law provisions in force as related to health and safety at the workplace.

**HIGHLIGHTING OF THE HOOKING POINT TO LIFT THE MACHINERY.****OBLIGATION TO USE THE SUPPORT FOOT, THE PARK BRAKE AND WHEEL LOCKING WEDGES.**

	USER'S AND MAINTENANCE MANUAL	Date:	25/02/2020
		Code	MAN GP75 ENG
Motocompressor : GP75		Revision	00

3.4 General notices

This manual includes the user's and routine maintenance instructions of the machinery. Whenever it is not specified otherwise, the operational and maintenance actions are to be considered as "specialized", i.e. they can only be performed by a technician appointed to the purpose.

Before undertaking any operation on the machinery, carefully read this manual.

ROTAIR S.P.A. declines any responsibility for any operation performed in conflict with the contents of this document.

Before utilizing the machinery, carefully read this document and comply with the safety law, regulations and standards in force.

This manual and the annexed documents must be considered as an integral part of the machinery they refer to and must always accompany the machinery, even if the latter is transferred to another user. It is therefore appropriate to preserve them for further reference.

This manual and the annexed documents are specific for the machinery they have been drafted for.



Do NOT utilize this manual and the annexed documents to run operations on similar machinery, of the same brand or typology.

ROTAIR S.P.A. is available to its Customer for any further information. Please report the information (type of machinery, model and code) contained in the machinery identification nameplate. All the specific data not indicated in the text are mentioned in chapter "Technical characteristics of the Machinery" as well as in the technical annexes of this user's and maintenance manual.

This manual thoroughly describes:

- The information relevant to towing, lifting and parking of the machinery;
- The general rules and recommendations useful for routine and extraordinary maintenance;
- The modalities to identify and order the spare parts.

Remark: the instructions for the appropriate use of the engine are described in the manual drafted by the engine manufacturer.

This manual must be preserved with care, in its folder, far from sources of humidity, heat and sun rays, so that it can be consulted at any time by both the personnel appointed to the use and by those who need to perform routine and extraordinary maintenance.

This machinery has been exclusively designed and manufactured to deliver compressed air in the conditions stated by the Manufacturer. Every other utilization not mentioned in the "expected uses" shall relieve the manufacturer from any liabilities, which will be at full charge of the user.

"Approved purpose" assumes compliance with the provisions reported hereinafter and related to the appropriate use and maintenance, as well as to the transport of the unit.

All the accident prevention regulations and standards in force need to be complied with as well, besides complying with the general rules in terms of safety and occupational medicine which are governed by the legislation in force.

The manufacturer declines any responsibility in case of changes made on the machinery without its authorization.

Before commissioning, the buyer must ascertain that ANY equipment or machinery, components and protection installations that are not part of the supply of this machinery comply with Machine Directive 2006/42/CE and to the other applicable European Directives (2006/95/CE - 2004/108/CE, etc.).

4 USE OF THE MACHINERY

4.1 Use allowed

The machinery described in this manual is motor compressor GP75.

The machinery is allocated to work outdoor.

The motor compressor is a piece of machinery with the capacity of generating a given quantity of compressed air in l/m by using a petrol engine as primary energy.

The pneumatic energy finds applications in different fields of use, where "pneumatic" operation tools, accessories and equipment are utilized. For instance: demolition hammers, drilling hammers, vibrators, drilling machines, rammers, coating machines, etc.

Each of these tools/-accessories has its own consumption of compressed air, expressed in litres per minute.

The optimum coupling between the compressor and the tool is achieved when the compressed air consumption does not exceed 85% of the air generated by the compressor (furthermore, it must be taken into consideration that the quantity of compressed air required by the tool shall increase in time, proportionally to the wear of the tool itself).

The correct compressor-tool coupling ratio allows the machinery operating in optimum conditions, as appropriate to ensure long life-span at the highest performance.

An oversized tool - besides creating unfavourable conditions for the appropriate operation of the machinery - shall not develop full performance, since it cannot resort to the required quantity of compressed air.

This machinery has been designed to work at ambient temperature ranging from -10 and +40°C.



WARNING: *It must be highlighted that the compressed air generated by this unit may contain some very fine traces of oil, therefore it is not appropriate to be utilized with those systems that call for fully oil-free air (e.g.: food processing and pharmaceutical industry, transports of flours and powders, cement, etc...).*

4.2 Use not allowed

It is not allowed to use the machinery for other processes than those which are mentioned in the section above. ROTAIR S.P.A. declines any responsibility as related to injuries or accidents due to lack of compliance with the specific provisions for use.

4.3 Residual risk



Avoid standing in front of the compressed air discharges. The direct exposure to the air jet may cause medium severity injuries because of the strength and speed of the compressed air.



The machine must operate outdoor, because of the presence of the engine and of the relevant exhaust gases.



It is strictly forbidden to operate the machine in indoor environments whose atmosphere is made of vapours or mixtures of corrosive or explosive gases.

When performing demolition, drilling, sandblasting activities or any other operation that generates dust the tool needs to be connected to the compressor through a pressure-resistant hose of sufficient length to keep the machinery away from the work area, thus preventing the clogging of both the exhaustion filters mounted on the unit and of the radiator for the cooling of the lubrication and cooling liquids. Even in this case, a good operator will locate the machinery leeseid versus the work area.

Even selecting the hoses to connect the machinery to the tool, make sure that they are sized as appropriate, taking into account their length, the volume of air which needs to pass through them and the service pressures: if the hoses show a too small diameter or excessive length, the air flow would interrupt, with subsequent loss of load and poor performance of the tool.

5 LEVELS AND QUALIFICATIONS OF THE PERSONNEL

The actions on the machinery must be performed by qualified, trained and informed personnel only. "Qualified personnel" means people who - based upon their profession - have acquired experience and instructions as well as knowledge on the relevant standards and provisions on accident prevention and operational conditions. Such personnel, appointed by the machinery safety managers, must be able to perform the required operations as well as to recognize and anticipate the potential hazards. Entrust the activities to appropriately trained or instructed personnel only; determine unmistakably the competences of the personnel as related to the fine tuning and to the maintenance and repair activities. Define the responsibility of the operators appointed to run the equipment, also through accurate written provisions and authorize them to reject provisions by third parties if in conflict with the safety regulations and standards.

Make sure that the activities are performed by purposely-appointed personnel only.

The actions on the electrical equipment of the machinery can be performed - in compliance with the electro-technical regulations and standards - only by qualified electricians or by people with an appropriate level of competences in the electro-technical field.

The mechanical and pneumatic maintenance can be performed by the operators of the authorized workshops only.



6 LIFTING INSTRUCTIONS

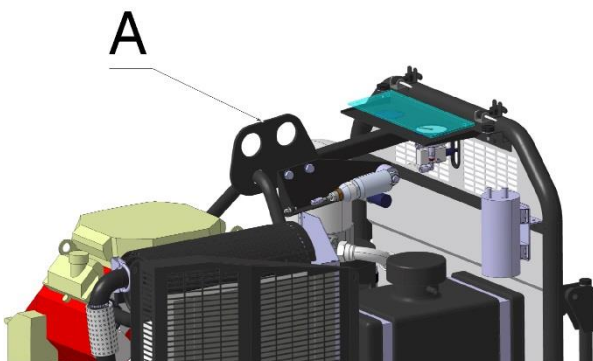

On lifting the bonnet access if possible to the lifting hook (Fig. 6.1 part. A)

- Check that the lifting element (crane, hoist etc) is suitable for the lifting of the weight of the unit (see par. 2.1)
- Hitch the fastener and the cable to the lifting hook.
- Lift the unit slowly and gradually.
- Always check - before handling - that there are no moving parts that may fall. In such case, attach them as appropriate.

- Check the status of ropes and chains before starting the handling operations.
- In any case, always make sure that the machine is solidly fixed to the rope and balanced as appropriate.
- Communicate the start-up of the maneuver as appropriate.
- Never leave the maneuver area with an overhanging load

Do not stand or transit under the overhanging load.
Avoid the machine swaying during sideways movements.



**WARNING
OVERHANGING
LOADS**



The user must periodically check the efficiency of the lifting equipment and replace it if it results to be no longer appropriate or safe.

No other hooking and lifting systems are allowed except those which are provided with the machine.



This pictogram allows pointing out the hooking system to lift the machine.

6.1 Safety provisions concerning maintenance

In order to perform the maintenance operations in safety conditions, the following provisions need to be complied with:

- The control and maintenance operations need to be performed by specialized qualified personnel aware of the indications shown in this manual. "Specialized qualified personnel" means people with the appropriate educational background and whose level of skills is appropriate to the kind of intervention and who have acquired experience and instructions on accident prevention and on the procedures required to perform maintenance operations;
- all the maintenance activities need to be performed after a safe stop of the machine and interrupting power supply to the engine;
- if the machinery is stopped during the maintenance and repair operations, it must be protected against accidental restart;
- in case of replacement of parts, the spare parts must be ordered at Rotair's customer service and must correspond to the technical standards defined by Rotair;
- the electrical equipment of the machinery must be periodically inspected. Any component's faults must be immediately pointed out and replaced after careful assessment of their effectiveness and efficiency;
- keep the greatest possible cleanness during the maintenance operations, avoiding using flammable solvents;
- before restarting the machinery after maintenance or overhaul, make sure that all the guards and safety devices are restored and operational.
- never use water to extinguish the flames in case of fire (Figure 6.1-1).



Figure 6.1-1

After performing the maintenance operations, it is mandatory to restore the protections and - in particular - on the area of the cooling fan moving organs



7 MACHINERY COMPONENTS

This unit is a single-phase, silenced oil injection screw mobile motor compressor.

The engine is internal-combustion, fuelled by petrol, and is connected to the compressor by belt transmission.

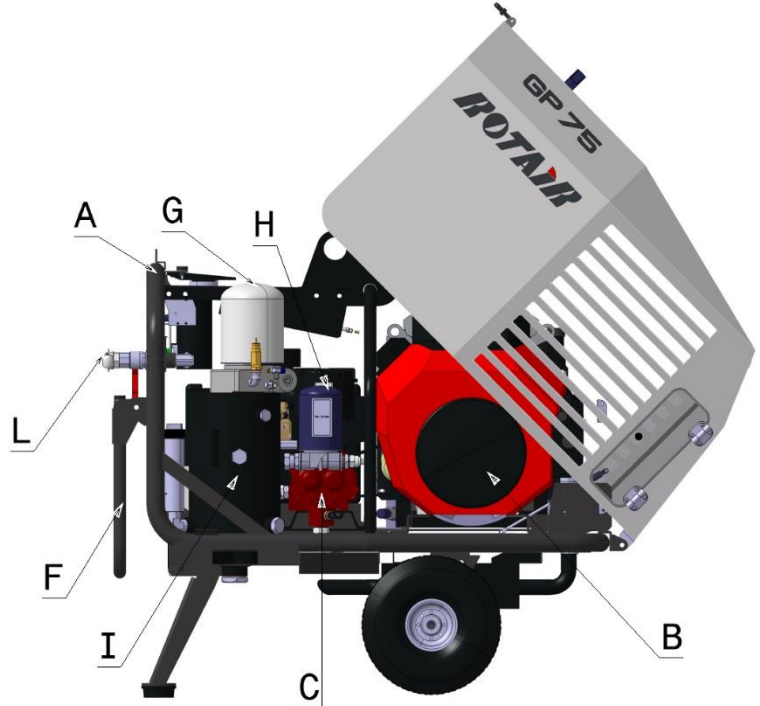

Figure 7-1

- A- Chassis
- B- Engine
- C- Compression unit
- D- Battery
- E- Fuel Tank (EPA-CARB)
- F- Tow-bar
- G- Separator filter
- H- Compressor Oil filter
- I- Separator tank
- L- Air tap
- M- Radiator

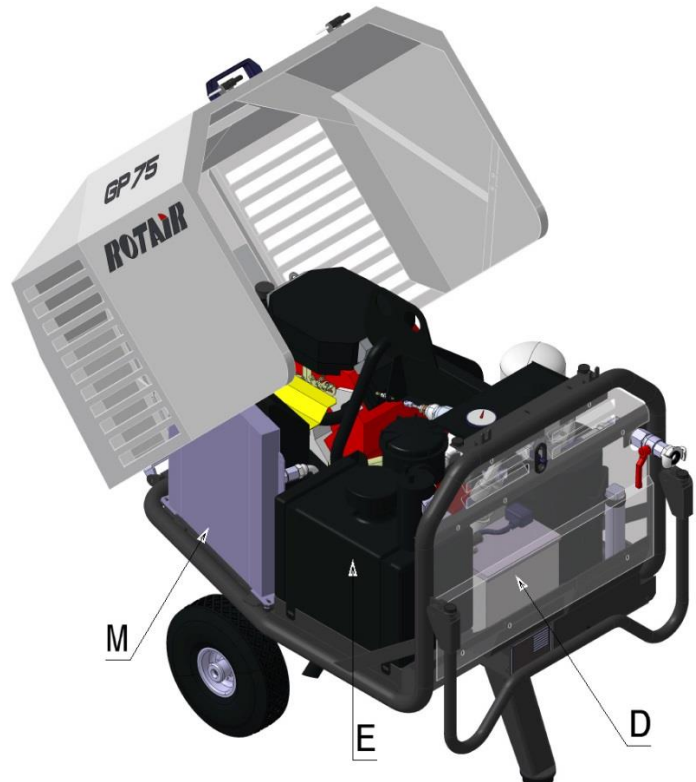



Figure 7-2

	USER'S AND MAINTENANCE MANUAL	Date:	25/02/2020
		Code	MAN GP75 ENG
Motocompressor : GP75		Revision	00

7.1 Chassis and tow-bar – Figure 7-1 Part. A and F

The chassis and the drawbar are made of pressed and electro-welded tubular material. The chassis is of self-supporting type as it supports all the machine components. Both the chassis and the drawbar undergo two painting treatments in order to guarantee their corrosion and rust resistance. The drawbar may be simply placed on top of the bonnet, thereby reducing the overall machine dimensions, by pushing down the drawbar so that it compresses the spring, turning the drawbar to the left at the same time.

7.2 Engine - Figure 7-1 Part.B

The unit is equipped with a petrol engine, the characteristics of which are described in paragraph 2. Consult the manufacturer's user and maintenance manual enclosed with this machine, for the user and maintenance instructions.

7.3 Compression unit and oil separator tank - Figure 7-1 Part.C and I

This compression unit is fully manufactured in the ROTAIR plants and it consists of a centre body (cylinder) which host inside two asymmetric profile screw rotors: a 5-lobe male one and a 6-lobe female one.

The cylinder is closed at its end by two heads that contain the bearings which withstand the radial and axial loads generated by the compression of the air.

A set of channels machined in both the cylinder and the heads send oil to the different components. The lubricant that is thus distributed - besides lubricating the bearings - allows keeping a shroud of oil between the rotors and between the rotors themselves and the inner walls of the cylinder, thus fostering tightness to compression. Another significant function of the oil injected between the rotors is the absorption of the heat generated by the compression of the air.

The compressed air supplied by this compressor is pulse-free and the compression is generated axially.

An "adjuster" unit is mounted on the compressor to regulate the quantity of air to let in as a function of the air which is being consumed. Upstream this unit, a double-stage filter ensures the greatest purity of the inlet air.

The separator tank is a pressure vessel and - because of its manufacturing characteristics - it does not need to be annually inspected by the body appointed to the verification of the requirements stated in directive 97/23/CE and is provided by the certificate of conformity released by the manufacturer. A nameplate welded on it reports all the identification and testing data.

Its lid is equipped with: the overpressure safety valve and the valve that adjusts the minimum pressure of the machinery.

7.4 Battery - Figure 7-2 Part.D

The machine's electric system is powered by a 12V battery providing continuous current in a special container fixed to the chassis.

7.5 Belts and pulley

The engine is connected to the compressor by means of belt transmission. The engine and compressor are installed on a slide support to guarantee the coaxiality of the same, and therefore the perfect alignment of the belts with the pulleys. There is also a simple pulling system to ensure perfect belt tightness (see instructions in chapter 11.10).

7.6 Control devices and instruments

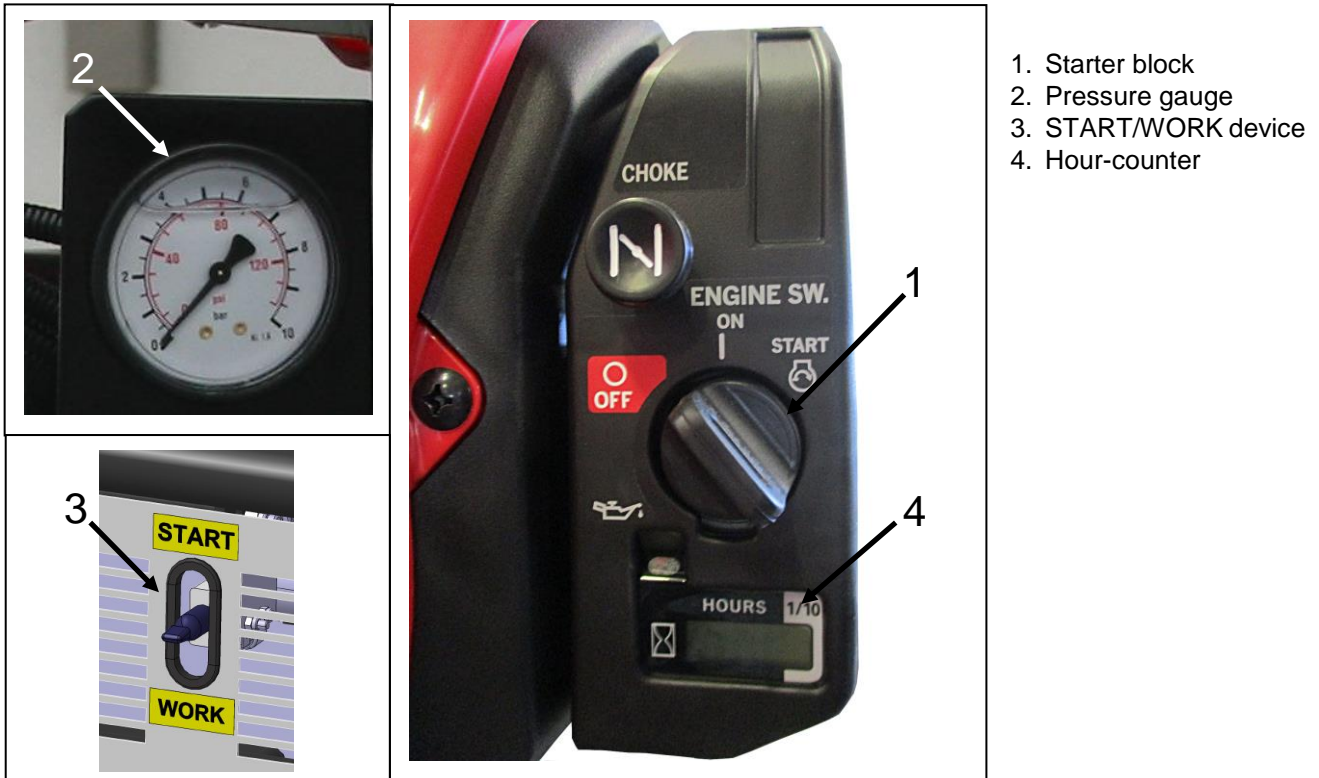

Refer to chapter 7 for details of the function of these devices.

7.7 Fuel tank- Figure 7-2 Part.E

Of 5.5 gal capacity and this tank meet the CARB (California Air Resource Board) and U.S. EPA (Environmental Protection Agency) requirements for evaporative emissions.

7.8 Cooling radiator- Figure 7-2 Part.M

Of large size to permit efficient oil cooling thereby permitting machine operation under extreme temperature conditions. The grill panel positioned in front protects the radiator from any accidental blows and from the risk of burns to the operator.

8 HYDRAULIC AND PNEUMATIC SYSTEMS

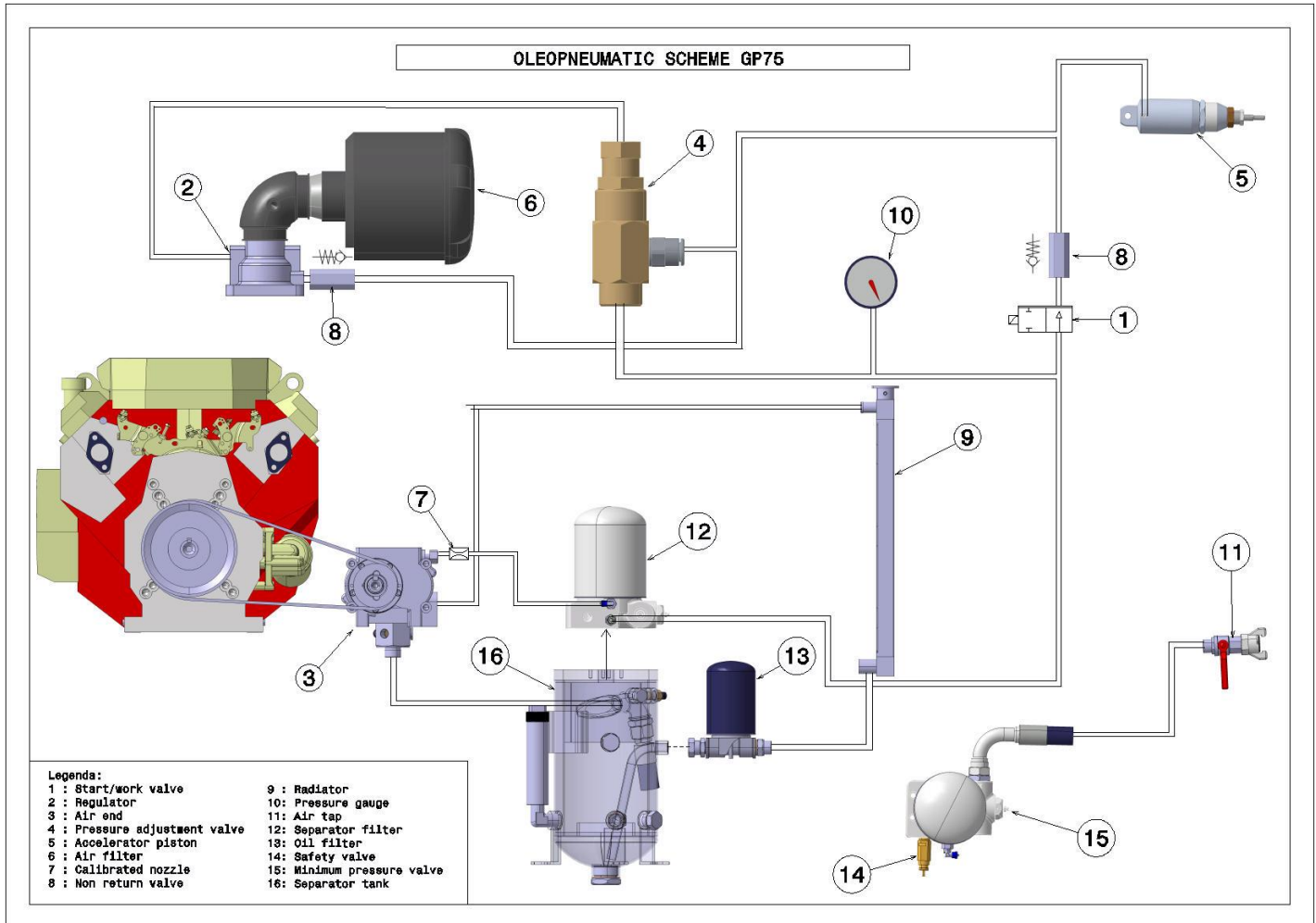

Figure 8.1-1 Hydraulic and pneumatic systems

The hydraulic lubrication system (Figure 8.4-1) of the compressor consists of:

- Separator tank (16);
- Separator filter (12);
- minimum pressure valve (15)
- oil filter (13);
- oil cooling radiator (9);

As you may notice, the lower portion of the separator tank (16) is used as oil tank while the minimum pressure valve located in the upper part (15) operates as a support of the separator filter (12).

When starting up the machinery, the oil under pressure located in the tank starts flowing through the duct into the oil filter (13), and from there to the cooling radiator (9).

The cooled filtered oil then reaches the compressor (3) and - by means of appropriate inner piping - is distributed to the different organs (rotors, bearings, etc.), which are thus lubricated and cooled.

From the compressor (3), the oil -mixed to the compressed air in input from the exhaust valve (2), is sent to the tank (16), where - through a forced centrifugal circuit - the compressed air is submitted to a first separation from

	USER'S AND MAINTENANCE MANUAL	Date:	25/02/2020
		Code	MAN GP75 ENG
Motocompressor : GP75		Revision	00

the oil.

The resulting compressed air leaves the separator tank through the separator filter (12), which will provide to a second and last separation of the air from the remaining oil.

Even though the separating filter (12) separates the air from the oil, it is worth pointing out that a limited quantity of the latter manages to penetrate inside the filter and deposits on the lower portion of the filter itself.

The oil is sucked into the piping where a calibrated nozzle (7) and a check-valve (8) will route it to the compressor (3).

The check valve (8) shall prevent the oil from retuning into the separator filter (12) when the machinery is stopped.

Attention! The oil filter (13) is provided with a "by-pass" valve which allows the oil to circulate also in case it is clogged. In such case, the oil shall circulate regularly without being filtered.



WARNING: The filter needs therefore to be replaced at regular intervals, as specified in the maintenance program.

8.1 Pneumatic system

The pneumatic system (Figure 8.4-1) includes:

- start/work valve (1).
- suction filter (6);
- suction adjustment valve (2);
- compressor (3);
- separator tank (16);
- separator filter (12);
- the min. pressure and check valves integrated in the composed valve (15)
- tap (11);
- Max. pressure record valve (4);

The sucked air, after passing through the air filter (6), reaches the suction adjuster (2) and then the compressor (3), which - after compressing it - conveys it -together with the injected oil - into the separator tank (16). Here the air is separated from the oil. This process - as indicated above - is made first of all by centrifugal force and then by the use of the separator filter (12).

Once the air is purified from the oil, is conveyed to the minimum pressure valve (15), which opens only when the pressure in the tank has reached the established value.

It is in any case a good practice not to use tools that - with their excessive consumption - may cause the lowering of the pressure in the tank under 5/5,2 bar. Lengthened working conditions below 5 bar may create insufficient separation of oil from air, with a subsequent anomalous consumption of lubricant.

Furthermore, the min. pressure valve (15) acts as a check valve, thus preventing the return into the unit of compressed air coming from piping or tools connected to the machinery.



WARNING: pressure vessel

	USER'S AND MAINTENANCE MANUAL	Date:	25/02/2020
		Code	MAN GP75 ENG
Motocompressor : GP75		Revision	00

9 PROVISIONS FOR THE APPROPRIATE UTILIZATION OF THE MOTOR COMPRESSOR

Consult this user's and maintenance manual before starting-up the machinery.

9.1 Before starting-up

Before starting up the machine carefully follow these procedures:

- Place the machine on a flat surface: an inclination of over 15° is not permitted.
- Check that the electric cables are connected to the battery terminals (if present); on making connection take the greatest care to ensure that the starter motor wire is connected to the (+) positive pole of the battery and that the earthing cable is connected to the negative (-) battery pole.
- Check the oil level in the tank: as concerns the various types and quantities of lubricant to be used, refer to the instructions contained in the manufacturer's user and maintenance manual enclosed with the machine documentation;
- Check the oil level in the compressor; it is necessary to wait for 5 minutes after the machine has stopped in order to allow the lubricant in circulation to completely flow out of the oil separator tank

It is essential to make sure that there is no pressure in the system before undertaking this operation (the gauge (2) in Chap.7.6 must be at 0 bar)

- Unscrew the cap of the filler shown in figure 12.7-1, part B, Chap.12.7 at the side of the oil separator tank
 - Check for the presence of oil which must be visible inside the filler
 - Add the required amount of oil ,if necessary
 - Use only the oil types indicated in chapter 12.7
- Fuel checking. Use fuels with similar characteristics as those indicated in the engine constructor's manual.
 - Check that there are no traces of oil or fuel inside the machine as the result of oil or fuel filling.

9.2 Machine start-up

- Fully close the air delivery tap
- Open the fuel cock (see engine manual)
- Pull the Choke (only if engine is cold)
- Position the start/work switch to START position (N.3 Chap.7.6)
- Turn the starter key (N.1 Chap.7.6) to the second notch which starts the machine.

Release the key as soon as the engine begins to rev.



Avoid prolonged start ups of over 10 seconds
In the event of difficult start up conditions, repeat the operations at short intervals.

Open the starter should it be closed (for cold starts)

	USER'S AND MAINTENANCE MANUAL	Date:	25/02/2020
		Code	MAN GP75 ENG
Motocompressor : GP75		Revision	00

With engine running and with switch positioned to START the engine runs at minimum speed and the gauge indicates a pressure of approx. 2-3 bar.

- Wait a few minutes for the engine to warm up.
- Position the start/work switch to WORK; the machine is now ready to supply air.
- Connect the compressed air delivery piping to the tool.
- Gradually open the air cock.

9.3 During the working stage

- The machine must always operate with bonnet lowered and closed.
- Check the fuel level.
- Constantly check that there are no foreign bodies around the machine which might accidentally get caught up in the cooling fan.



Do not operate the machine with cock excessively open: working pressure must never fall to under 4,8 ÷ 5 bar

9.4 Machine stopping



**IMPORTANT:
Never stop the engine when under load!**

Before stopping the engine proceed as follows

- Slowly close the air delivery cock
- Position the switch to START
- Wait for the pressure to fall to a value of between 2-3 bar
- Turn the ignition key in an anti-clockwise direction to initial position.

9.5 After machine stopping

- Should the machine have been working in very dusty environments it is necessary to clean or replace the oil filter (chap.12.6), and also check the state of cleanliness of the cooling radiator, cleaning it by means of air jets if necessary.
- Also ensure that there has been no fuel or lubricant leakage during operations, if there has, find the cause.
- Store the machine in a covered area if possible

10 MACHINE CALIBRATION AND TUNING

10.1 Maximum engine speed check

The maximum speed is calibrated, established and sealed by the manufacturer. It cannot therefore be modified for any reason.

Tampering with the seals in order to alter the maximum rotation revs will immediately render the guarantee void, both in relation to the engine and the compressor.

Any checks and calibration of the maximum and minimum running speeds are to be undertaken by specialized personnel, equipped with special speedometer with refracting measuring device complete with ear-protection muffs.

To calibrate max and min engine speed controls refer to the owner's manual of the engine manufacturer attached to this documentation.

It is advisable that any work on the injection system (injectors, feeder pumps etc) be undertaken by the **"Assistance service"** authorized by the engine manufacturer, especially if still under guarantee.

10.2 Final maximum pressure checking and calibration

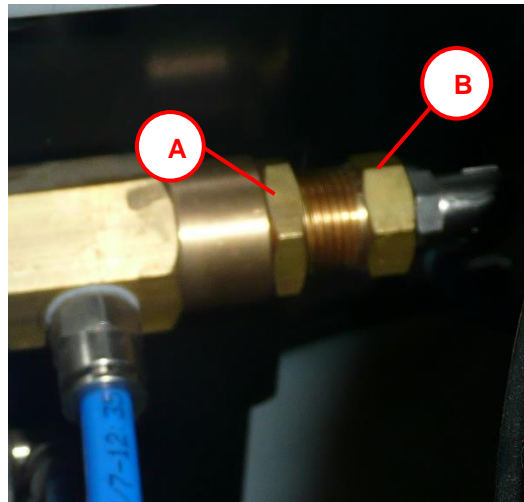

Figure 11.2-1 Adjusting maximum pressure pneumatic circuit

The maximum pneumatic pressure is calibrated during the testing phase of the machine.

If the value of the maximum pressure pneumatic, indicated by the pressure gauge on the control panel, diverged over a $\pm 5\%$ from the value specified in Paragraph 2 of this manual, proceed as follows:

1. Start the machine as described in section 10.2 "Start",
2. Wait for the compressor reaches the maximum pressure and the engine stating the values of idle speed;
3. Close all faucets;
4. Open the bonnet with the compressor in motion;
5. Unscrew with wrench 22 mm in, the nut (Letter A in Figure 11.2 1); Air filter area:
6. If you want to increase the maximum pressure must tighten with 19 mm wrench, nut (Letter B in Figure 11.2 1);
7. If you want to reduce the regime min unscrew, with a 19 mm wrench, nut (Letter B in Figure 11.2 1);
8. Once the adjustment screw, with a 22 mm wrench, nut (Letter A in Figure 11.2 1);
9. Slightly open for 3/4 seconds, the faucet supply air to the engine to accelerate, and then close it. Repeat

this 2-3 times to allow the settling of the valve.

10. Reading on the pressure gauge located in the control panel, the value of the maximum pressure reached;
11. Compare the measured value with that reported in Paragraph 2, repeat the steps up to the alignment of the two values;
12. Close the bonnet.



WARNING: Notice: if the gauge had a discontinuous, jerky, you will have to replace it. So, before making any calibration valve high or low pressure, make sure that the gauge is efficient and reliable.

10.3 Minimum pressure calibration and checking

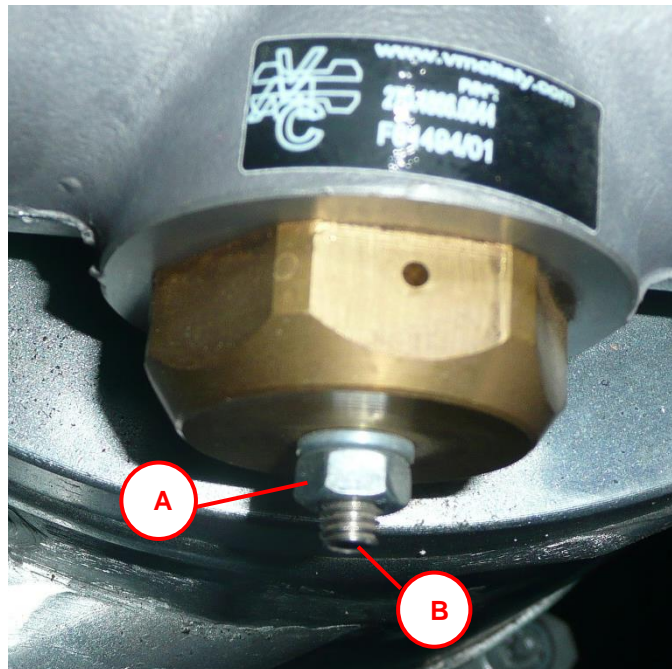

Figure 10.3-1 Adjusting minimum pressure pneumatic circuit

The minimum pneumatic pressure is calibrated during the testing phase of the machine.

If the minimum pressure pneumatic, indicated by the pressure gauge on the control panel, diverged over a $\pm 5\%$ from the value specified in Paragraph 2 of this manual, proceed as follows:

1. Start the machine as described in section 10.2 Start.
2. Wait for the compressor reaches the maximum pressure and the engine stating the values of idle speed;
3. Gradually open the air valve;
4. Open the bonnet with the compressor in motion;
5. Unscrew, with 10 mm wrench, nut (Letter A Figure 10.3 1)
6. If you want to increase the maximum pressure must tighten the Allen screw (Figure 10.3 Letter B) with Allen key 3 mm;

7. If you want to reduce the regime min loosen the Allen screw (Figure 10.3 Letter B) with Allen key 3 mm;
8. Once the adjustment screw, with a 10 mm wrench, nut (Letter A Figure 10.3 1) and turn off the taps;
9. Reopen slowly the air tap and close it again repeating the process a few times to allow the settling of the valve;
10. Close the bonnet.



WARNING: *Pressure vessel*

10.4 Safety valve check

It is installed on the oil separator tank and operates to discharge any unwanted and accidental overpressure. This valve is calibrated and checked at the factory and cannot be altered or tampered with for any reason. A routine efficiency check must be undertaken as follows:

1. Start up the machine as described in paragraph 9.2.
2. With cocks closed and engine running at minimum speed, lift up the pin using a pair of pliers as indicated in fig.10.4-1 and release as soon as the valve appears to discharge air.

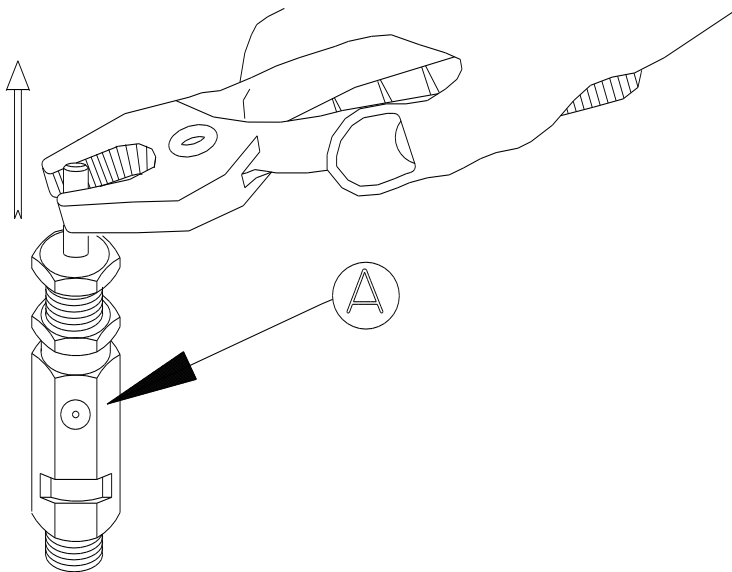

FIG. 10.4-1



IMPORTANT: *The air escaping from the valve during these checking operations is mixed with oil particles, and therefore it is advisable to cover the valve with a cloth to prevent the operator from getting dirty.*

Should it prove impossible to pull up the pin with the pliers, the valve will be prevented from breathing and must therefore be replaced immediately.

In the event of replacement the new safety valve must be of the same type as the original and be complete with conformity certificate issued by the manufacturer.

As it is a very important valve, which helps to protect the system from any damaging excessive pressure, which may also cause the piping or oil separator tank to explode, it is advisable to request an original spare from ROTAIR S.P.A. SPA, citing the relative machine serial number.

The use of non- original safety valves will exonerate ROTAIR S.P.A. from all liability

	USER'S AND MAINTENANCE MANUAL	Date:	25/02/2020
		Code	MAN GP75 ENG
Motocompressor : GP75		Revision	00

11 MAINTENANCE PROGRAM

This programme provides a list of all the routine operations to be undertaken on the various machine components and which are essential to ensure efficient function and a long working life.

ORDINARY MAINTENANCE

It can be undertaken by the machine operators themselves, and includes all those periodic routine operations such as checking of the oil level, air filter, fuel top ups, and all cleaning and checking operations in order to trace any fuel or lubricant leakage inside the machine.

Here follows a list in order of frequency of all those operations relating to the compressor part, while those relating to the "engine" part it is necessary to refer to the USER AND MAINTENANCE MANUAL of the engine manufacturer itself, which is enclosed with the machine.

11.1 Daily checks

Before starting the machine:

- Compressor oil level check
- Engine oil level check (consult manufacturer's manual).
- Check for any fuel or lubricant leaks.
- Fuel fill up

Daily and with machine running:

- Check on maximum pressure value
- Check on minimum pressure value

Weekly:

- Compressor air filter check
- Engine air filter check (see constructor's manual).
- Check on battery electrolyte level



IMPORTANT: *Should the motorized compressor operate in very dusty environments, the air filter needs to be checked, cleaned or even replaced even more frequently than indicated above.*

11.2 Every three months

- Belt tension check
- Check on engine maximum speed level
- Safety valve efficiency check
- Oil cooling radiator cleaning
- Oil recovery nozzle check
- Fuel tank drainage

11.3 General maintenance program

In this program are listed all the interventions and their frequency to be executed on the various components of the machine. Such interventions are essential for the proper functioning of the machine and its mechanical durability over time.

RECOMMENDED OPERATIONS	FREQUENCY
Checking the oil level compressor	Daily
Check engine oil level (refer to the manufacturer's manual)	Daily
Checking Coolant Level	Daily
Check fuel level and top up (if necessary)	Daily
Check oil or fuel leakage	Daily
Check the readability of measuring instruments	Daily
General cleaning operations	Daily
Control of the absence of obstructions to the ventilation system	Daily
Control and clean up the air filter	Every 100 hours
Control and thorough cleaning air filter in dusty	Daily
Control of the air filter Compressor	weekly
Control of the engine air filter	(Ref. Manual of the engine manufacturer).
Checking the battery electrolyte level	Monthly
Checking tire pressure	Monthly
Checking belt tension Quarterly	Three months
Speed control the minimum and maximum engine	Three months
Control of the efficiency of the safety valve	Three months
Cleaning the oil cooler	Three months
Control nozzle oil recovery	Three months
Drainage of the fuel tank	Three months
Replacing petrol pre-filter	Every 500 hours
Control and wheel lock	Three months
Change engine oil	(Ref. Manual of the engine manufacturer).
Oil Filter Replacement compressor	After the first 50 hours
Replacing compressor oil	After the first 50 hours
Control of tightening screws and bolts	Every 100 hours
Check tightness of all pipe connections	Every 100 hours
Replace Air Filter Compressor	After 500 hours
Replace oil filter compressor	After 500 hours
Replacing compressor oil	After 2000 hours
Replacing oil separator element	After 2000 hours
Check-up by the service "authorized Rotair".	Every 3000 hours
Control readability nameplate EC Annual	Annual
Control valves from service "authorized Rotair".	Biennial

The ROTAIR S.P.A. disclaims any responsibility for the failure to comply with maintenance requirements in the table above.

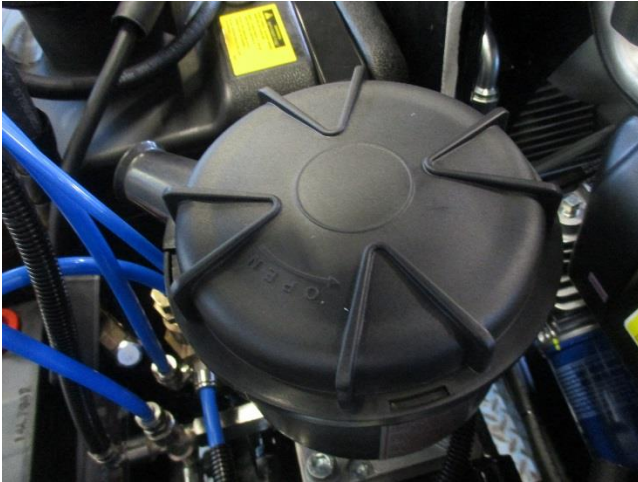
12 PERIODIC MAINTENANCE**12.1 Air filter check****Fig. 12.1-a****Fig. 12.1-b**

The duration and efficiency of the compressor greatly depends on effective maintenance of the air filter. Clogged filters will result in a loss in performance levels causing premature compressor wear.

This check is to be undertaken at regular intervals every 100 working hours; however in the event of very dusty conditions it may be necessary to undertake the check on a daily basis.

The filtering cartridge (fig 12.1-b) can be cleaned using a series of air jets but it must never be washed. They must however be replaced every 500 working hours.

To replace the air filter, take the cap (picture 12.1-a) away by rotating it and then take the filter (picture 12.1-b) away. Put the new filter and close the cap again.

12.2 Battery check



Figure 12.2-1 Battery compartment



Extended not-use of the machine - battery charge status



- To avoid complete discharge of the battery, if the machine is not to be used for > 3 months, disconnect the negative terminal of the electrical system.
- Periodically check the battery charge and recharge it every 3 months.

Cleaning the terminals

The battery terminals (poles) must be cleaned and greased periodically. The accumulation of dirt can hinder the passage of electric current.

For cleaning it is necessary to switch off the machine, disconnect the terminals starting from the negative terminal and clean the terminals.

Checking the clamps

Generally the negative and positive pole of the battery are greased (eg. Pulp vaseline or similar product) to avoid the oxidation of metals. The paste on the clamps must be periodically replaced.

In the same way, check that the terminals are firmly connected to the battery poles and if necessary tighten them. In fact, it may happen that vibrations loosen the grip of the clamps. A mobile connection can cause malfunctions and even failures to the vehicle's electrical devices.

Checking the battery fluid (in the case of an unsealed battery)

The electrolyte must always reach the covering level of the element plates.

If the battery fluid is low, it may compromise its operation.

In these cases, if the level of covering is below the minimum level it is necessary to have it checked by a qualified electric maintenance technician and if necessary to provide the addition of cold water distilled water to restore the liquid level.

If, despite top-up, the battery continues to discharge frequently, it must be replaced.



CAUTION: Take special care when handling battery fluid. Potentially corrosive liquid.

12.3 Cooling radiator cleaning

The compressor and engine cooling liquids are cooled through a radiator, which must therefore be kept clean to ensure that the ventilation air enters easily and freely through its honeycomb flaps.

In the event of the clogging of the flaps with dust or any other foreign particles, there is a risk of harmful and damaging overheating of the mechanical parts of the screw compressor, severely affecting its efficiency and working life. Regularly checking is therefore recommended and if necessary it should be cleaned using compressed air or washed using a pressurized water jet.

12.4 Oil recovery nozzle checking and cleaning

Control and clean the oil recovery is to be performed, should you find a leak of oil mist mixed with air compressed, operating as follows (Figure 12.4-4).

- 1) Unscrew the fitting located at the center of the tank (Letter Z in Figure 12.4-4);
- 2) Inside the ring (Letter Z in Figure 12.4-4) is a nozzle (Letter U in Figure 12.4-4): make sure that its calibrated hole is not blocked (blow with compressed air);
- 3) Replace the fitting.



WARNING: During normal operation of the compressor, in the pipe from the fitting transparent part (Z), you will notice a certain amount of oil flow from the said fitting (Z) towards the head of the compressor

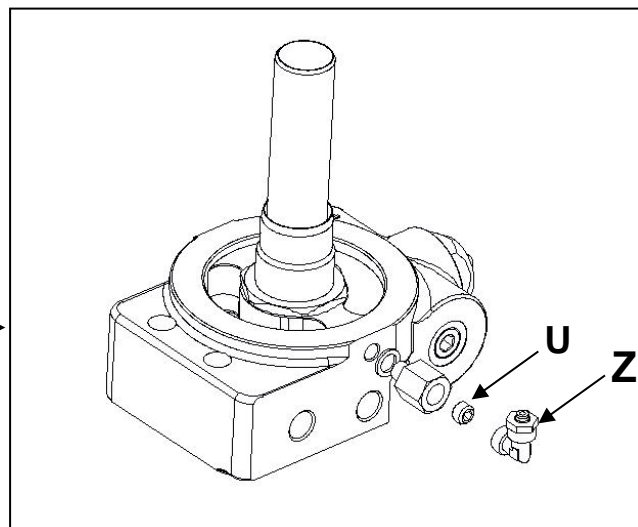

Figure 12.4-4 Nozzle oil recovery

12.5 Fuel tank drainage

The purpose of this operation is to eliminate any water which may have accumulated at the bottom of the tank, as the result of condensation or the entry of polluted fuel.

It is very important to undertake regular drainage, to prevent the risk of even the slightest amounts of water from being taken in and injected into the engine; which would be sure to cause the pump or the injection system to break down, as well wearing out the cylinders with consequential loss in engine power.

It is also advisable to refill with fuel at the end of each work shift to prevent any temperature variations on the tank walls causing any condensation to form inside the tank itself.

Whilst undertaking tank drainage it is also necessary to replace the fuel filter in order to eliminate all traces of

water from the feeder system.

The tank must be drained at least 30 minutes after having switched off the machine, in order to provide enough time for the water to separate from the gas oil and deposit on the bottom of the tank.

To drain the fuel from the tank simply extract the tank, after disconnecting the piping by means of the bayonet joint, and pour into a special container. For best results it is advisable to keep the tank turned over for a few hours,

The polluted fuel escapes from the exhaust element and must be collected and sent to authorized and specialized pollutant refuse collection centres. It must not on any account be dispersed into the surroundings or waterways, neither must be conveyed through public sewerage systems.

12.6 Compressor oil filter replacement



- Use a chain pipe wrench in order to loosen the filter to be replaced (Fig.12.6-1 part. A).
- Lubricate the seal of the new filter which must be screwed and unscrewed **by hand only**.
- Start up the machine making sure that there is no sign of leakage around the seals; if there is; switch off the machine and check that the seal is in good condition and correctly positioned in its relative slot.



IMPORTANT: The used filter is soaked with pollutant and harmful mineral oil. It must therefore be sent to the specialized collection centres.

FIG. 12.6-1

12.7 Compressor oil replacement

The oil compressor must be performed taking into consideration the working conditions in which the machine operates (dusty, very high temperatures, etc.).

The oil change intervals must never exceed 2.000 hours of work.

In conjunction with the replacement of the oil must be changed the corresponding filter.

ENVIRONMENTAL MEDIUM TEMPERATURE

Up to 40 C°/ 105 F°		Up to 55 C°/ 131 F°	
RECOMMENDED OIL PART NUMBER	AL-00025	RECOMMENDED OIL	BRAND
		SINCOM 68	Q8
COMPATIBLE OIL	BRAND	COMPATIBLE OIL	BRAND
DICREA 46	AGIP	SCHUMANN 68	Q8
COMPRESSOR OIL 46	API	RARUS SHC 1026	MOBIL
ENERGOL RC-R 46	BP OIL	CORENA S4 R 68	SHELL
COMPRESSOR 46	ERG	CORENA D 68	SHELL
RARUS 425	MOBIL	DACNIS 68	TOTAL
SCARLATTI 46	Q8		
LR CCW 46	ROLOIL		
CORENA D 46	SHELL		
DACNIS VS 46	TOTAL		



WARNING: It is strictly recommended to use ONLY OIL FOR SCREW COMPRESSORS.
ROTAIR S.P.A. declines any responsibility if other oils will be used.



12.8 Checking of oil separator element

Filter life oiler is expected around 2000 hours of work, but is closely related to a careful observance of all maintenance requirements given in this manual.

A quantity of oil or excessively low in the tank, the breach of the frequency of oil changes or the use of the machine with cooling radiator clogged may determine an anticipated and irreparable deterioration of the filters. Therefore, if, after the control and clean the recovery (operation described in the paragraph 13.4.8) and making sure the proper oil level in the tank, you are still traces of oil in the compressed air, it will have to replace the exhaust cleaner.

To ascertain the degree of clogging of the filter separator operate as follows:

- 1) Install a pressure gauge upstream of the separator and make sure that on the machine is efficient.
- 2) Start the machine.
- 3) Partially open the faucet flow until the pressure gauge on the control panel shows the value of the operating pressure.
- 4) Read the value of the pressure gauge located upstream of the oil separator filter and compare two values: if, between the two readings, is a difference of more than 1 bar replace the filter separator

The oil separator filter must never be washed with water.



WARNING: *Pressure vessel*

12.9 Instructions for oil separator element replacement

To replace the oil separator filter proceed as follows:

- 1) The operation must be performed with the machine stopped and in the absence of pressure in the oil separator tank.
- 2) We recommend applying a cloth in order to contain any oil leakage that may occur during the replacement of the oil filter.
- 3) Unscrew the oil separator filter: the filter is situated above the oil separator tank
- 4) Replace the new filter making sure to lubricate the gasket.
- 5) The filter must be tightened by hand only.



Figure 13.4-7 Oil separator filter



WARNING: *Pressure vessel*

12.10 Control , tension and replacement of transmission belts

The transmission belts must always be perfectly tightened in order to ensure the regular and efficient function of the motorized compressor.

In order to determine the precise tension of the transmission belts it is necessary to proceed as follows

Apply a force "F" of between 25 and 27N at the average point of the free "T" section of a belt, the "f" arrow must be of 5.9 mm. Should the value of the "f" arrow be above this value it means that the belts have become loose, while if the value is below this it means that they are too taut.

When checking the belts it is also advisable to check their conditions and replace immediately if necessary.



WARNING: Caution: The straps too loose can cause them slip with loss of compressor power.

The straps too tight deteriorate with the consequent rupture of the same.

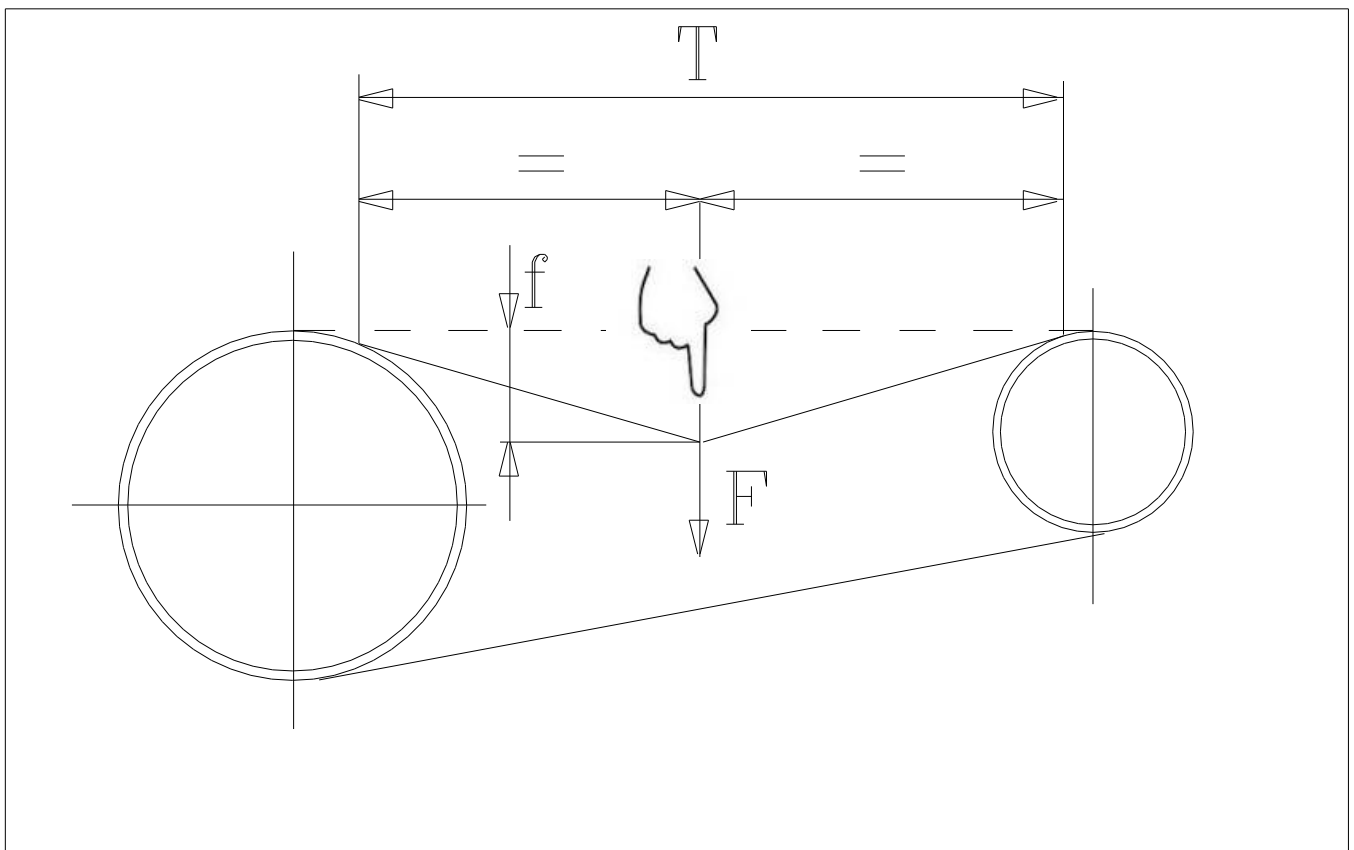

Figure 12.10-1 Tensioning straps

To regulate the belt tension it is necessary to proceed as follows (Fig.12.10-2 Motorized compressor seen from below)

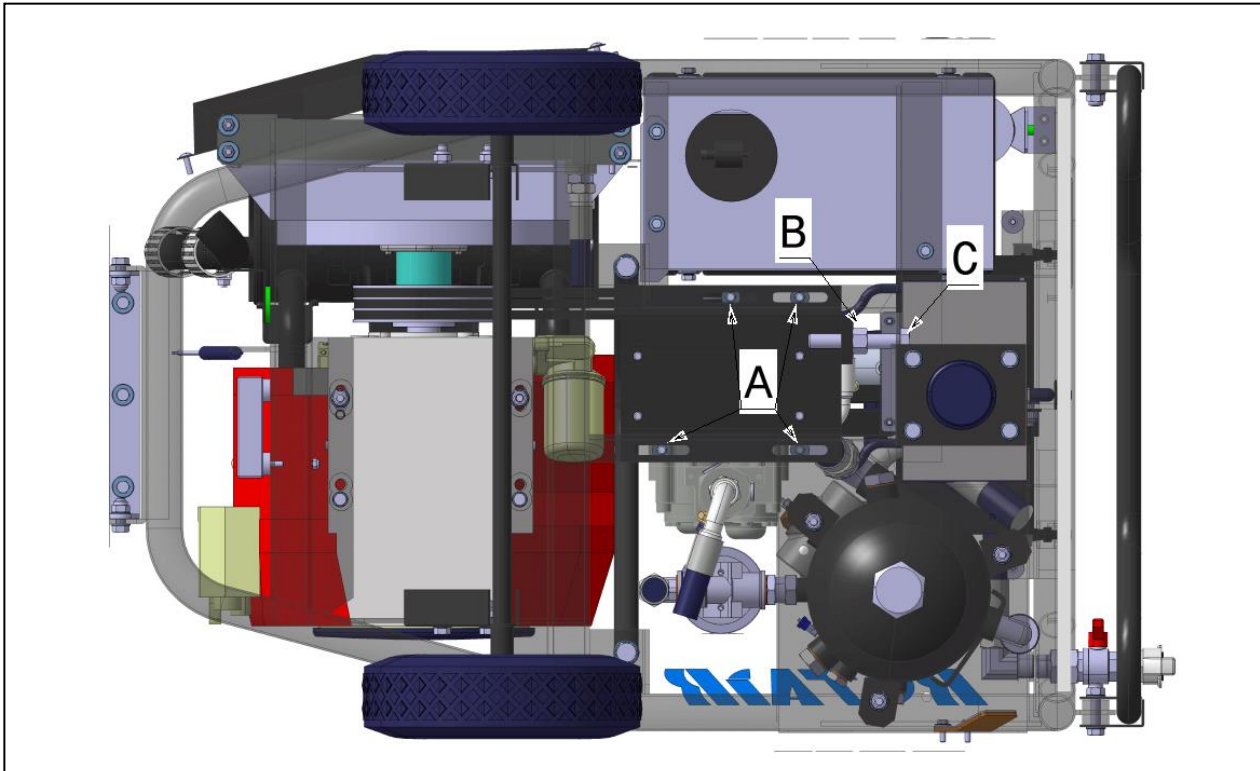

Fig. 12.10-2

- Loosen the 4 screws (part A)
- Loosen counter nut B
- Use bolt C for tightening. Tightening it, the belts will be tightened, loosening it will loosen them.
- When the right degree of tension has been obtained tighten counter nut B.
- Firmly tighten the four A screws

12.11 Transmission belt replacement

Before replacing the transmission belts it is necessary to ensure that the motorized compressor cannot be started up under any circumstances.

The operations to be undertaken are as follows:









1. Remove the protective casing of the belts
2. Loosen the screws (part.A fig.12.10-2)
3. Loosen the counter-nut (part. B fig.12.10-2)
4. Fully loosen the tensioning screw (C) using a lever to push the compressor unit towards the engine until the belts come out without any problem.
5. Replace the belts.
6. Tighten the regulation screws (C) to obtain the correct level of belt tightness
7. Firmly tighten the counter-nut (B)
8. Tighten the fixture screws (A)

Motocompressor : GP75

12.12 Values of tightening screws and bolts

For the correct tightening of screws and bolts on the machine please observe the tightening values corresponding to the class of coupling illustrated in the table below.

We recommend the use of torque wrenches for tightening the screws and bolts on the machine.

Torques not binding N.m (Newton meters)							Couples test sockets for hexagonal screws								
	Tightening values for classes of coupling according to DIN 267														
	4.6	5.6	6.9	8.8	10.9	12.9									
M 2	0,123	0,162	0,314	0,373	0,520	0,628	4			1,90					
M 2,2	0,196	0,265	0,510	0,598	0,843	1,010	4,5*			2,64					
M 2,5	0,284	0,373	0,726	0,863	1,206	1,451	5			3,55					
M 3	0,441	0,588	1,128	1,344	1,883	2,256	5,5			4,64		14,4			2,32
M 3,5	0,677	0,902	1,736	2,060	2,893	3,481	6*	17,6	7,4	5,92		17,6			2,96
M 4	1,000	1,344	2,599	3,040	4,315	5,148	7	25,2	11,4	9,12		25,2			4,56
M 5	1,916	2,648	5,099	6,031	8,483	10,200	8 9*	34,5 45,4	16,6 23	13,3 18,4		34,5 45,4	34,5 45,4	6,65 9,20	
M 6	3,432	4,511	8,728	10,300	14,710	17,652	10	58,1	31	24,8	58,1	58,1	58,1	12,4	
M 7	5,590	7,453	14,220	17,162	24,517	28,439	11 12	72,7 89,1	40,4 51,5	32,3 41,2	72,7 89,1	72,7 89,1	72,7 89,1	16,1 20,6	
M 8	8,238	10,787	21,575	25,497	35,304	42,168	13 14*	107 128	64,5 79,4	51,6 63,5	107 128	107 128	107 128	25,8 31,7	
M 10	16,67	21,575	42,168	50,014	70,608	85,317	15 16 17	150 175 201	96,2 115 134	77,0 92,3 107	150 175 201	150 175 201	150 175 201	38,5 46,1 53,5	
M 12	28,44	38,246	73,550	87,279	122,60	147,10	18 19* 20*	230 261 294	160 186 215	128 149 172	230 261 294	230 261 294	230 261 294	64,0 74,5 86,0	
M 14	45,11	60,801	116,70	138,30	194,20	235,40	21 22* 23*	330 368 408	247 281 319	198 225 255	330 368 408	330 368 408	330 368 408	99,0 112 127	
M 16	69,63	93,163	178,5	210,80	299,10	357,90	24 25* 26*	451 496 544	359 402 449	287 322 359	451 496 544	451 496 544	451 496 544	143 161 179	

13 SPARE PARTS



In case of need to order a single component contact your authorized service center Rotair.

14 FAULTS AND TROUBLESHOOTING

Problem	Cause	Solution
The engine fails to start.	Battery discharged or defective.	Recharge and replace if necessary.
	Terminals of the battery cables oxidized or loose.	Cleaning of the same and their tightening.
	No fuel.	Top up the fuel in the fuel tank.
	Solenoid faulty fuel.	Seek customer service by the manufacturer of the engine.
	Air in the fuel pipe.	Locate the infiltration by careful verification of all pipes.
	Injection pump defective.	Call in Customer Service by the engine manufacturer.
	Temperature sensors defective.	Remove all the electrical wires from it one at a time, to find the defective one and then replace.
Opening the taps the motor does not accelerate.	Starter defective Injectors failures	Call in Customer Service by the engine manufacturer.
	"Start-Work" switch positioned to "Start".	Position the switch to "Work".
The engine speeds up but no air come out	Defective maximum pressure regulation valve.	Dismantle and carefully check the spring and the conical slot. If it is defective and cannot be repaired the valve needs to be replaced. Replace and regulate the maximum pressure according to the instructions in paragraph 10.2.
	Blocked minimum pressure regulation valve.	Dismantle the piston and check that it is free to move. Check the conditions of the spring. In the event of an irreparable defect the valve needs to be replaced. Re-assemble it and calibrate the minimum pressure level according to the instructions in paragraph 10.3.
The machine stops suddenly and can only be restarted after a few minutes of waiting.		Take off one at a time, locate the probe that determines the stop. If that proves to be placed on the engine, check the oil level of the motor, the voltage and the conditions of the alternator belt. For water-cooled engines, check the coolant level.
	A temperature sensor detects a temperature anomaly and consequently stops the machine.	If it turned out to be the probe placed on the compressor control the level of 'oil in the tank and if necessary top up; Check the cooling fan and clean the radiator;

Motocompressor : GP75

Problem	Cause	Solution
		replace the oil filter of the compressor. If that proves to be positioned on the oil separator tank, check the oil separator filter following the instructions to Par.12.8 proceeding to its eventual replacement Par 12.9.
The engine does not reach the maximum speed of the speed indicated and the compressor does not do.	The spring piston accelerator is broken or to be put under tension.	Check the tension of the spring piston accelerator (Par. 10.1).
	Engine speed lower than expected.	Have the injection apparatus of the motor by qualified personnel. Replace the fuel filter. Run the draining of the fuel tank (Par. 12.5).
Oil leaking from the taps.	The machine has been stopped with switch positioned on "work".	Close the cocks. Place the switch to "Start" and wait 30-40 seconds before stopping the machine.
	Minimum working pressure too low.	Adjust it according to the instructions of Par. 10.3.
	Too much oil in the tank.	To the correct level (Par.9.1).
	The machine works in non-horizontal position.	Ensure position the machine level
	Nozzle clogged oil recovery.	See Par. 12.4
	Defective Separator filter.	See Par. 12.9

15 DISPOSAL, ELIMINATION, DISPOSAL OF THE MACHINE

15.1 Instructions for dismantling

To dismantle the machine safely, proceed as follows:

- 1) Place the machine in a wide and make sure it is turned off.
 - 2) Empty the liquid waste in the tanks of motor oil, fuel, coolant, hydraulic oil and store them in special containers. For disposal of these types of waste follow the next paragraph.
 - 3) Loosen the screws of the body and remove covers
 - 4) Remove all the components of the machine one by one dividing them according to their material composition
- The various components of the machine have to be disposed in relation to the type of waste to which they belong.

The following describes the different types of waste that can be generated during the life of the machine:

- Waste motor oil
- Waste hydraulic oil
- Residues of coolant
- Residual fuel
- Liquid remaining battery power
- Rags or paper impregnated with a diluents or other substances used for the cleaning of the various organs of the machine

16 ELIMINATING THE MACHINE

The operations of destruction and disposal must be carried out in a safe condition by a qualified specialist and after carefully reading and incorporated the recommendations and instructions provided in this section of the manual of use and maintenance and consulting the safety data sheets relating to substances in the machine mentioned in the previous chapter..

Once you reach the end of the mechanical life of the compressor, this has to be taken out of service so that it cannot be used for other purposes.

17 WASTE MANAGEMENT



The withdrawal of special waste and / or hazardous should be entrusted with the written contract to authorized firms; and those who physically transport and handling must be in possession of the required authorizations. The hauliers authorized must be enrolled in the relevant register.

18.1 Special waste

They are considered a hazardous waste residue from industrial, agricultural, crafts, commercial and service, for quality or quantity, is declared similar to municipal waste. These include also: machinery, equipment and metal parts of engines deteriorated and obsolete.



18.2 Toxic and hazardous waste



Are considered hazardous toxic waste all waste containing or contaminated by the substances listed in Directives 75/442 / CEE, 76/403 / CEE and 768/319 / CEE or other regulations in the countries of use and installation of the machines.



18.3 Temporary storage



Are considered hazardous toxic waste all waste containing or contaminated by substances listed in Directives 75/442 / CEE, 76/403 / CEE and 768/319 / CEE or other regulations in the countries of use and installation of the machines.

Temporary storage of toxic and hazardous waste is allowed according to the expected disposal of waste by treatment and / or final disposal. In any case, observe the mandatory laws of the country of the user in the field of environmental protection.

18.4 Features of the containers

The fixed and mobile containers, designed to contain toxic and hazardous waste must possess adequate strength requirements in relation to the chemical-physical properties and to its hazardous characteristics of the waste contained. The containers in which products are stored or dangerous or harmful materials must, in order to disclose the nature of their content, carry signs and markings prescribed.



18.5 Registration requirements

In accordance with the EU Directive 75/439 / CEE on the disposal of waste oil, the records of loading / unloading must be kept by all companies that produce hazardous waste or hazardous toxic from industrial and artisanal (in each case the 'Users should refer to the regulations implementing that Directive in the country of installation and use of the machines).

PARTS LIST

GP 75



Via Bernezzo 67 – 12023 CARAGLIO (CN) –ITALIA

TEL: +39 0171 619676 – FAX: +39 0171 619677

E-MAIL: info@rotairspa.com WEB: <http://www.rotairspa.com>

Copyright © 2014, ROTAIR S.P.A. - All rights reserved This manual is intellectual property of ROTAIR S.P.A. Its full or partial reproduction is forbidden under any form, on any support and by any means, without the written authorization by ROTAIR S.P.A.

This page has been intentionally left blank

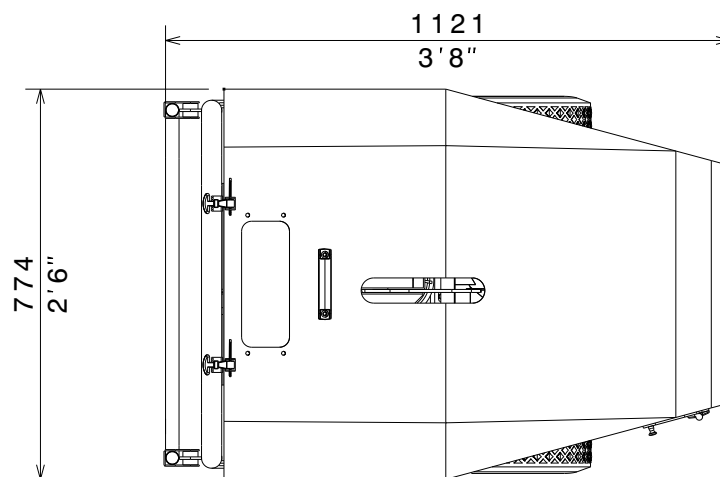
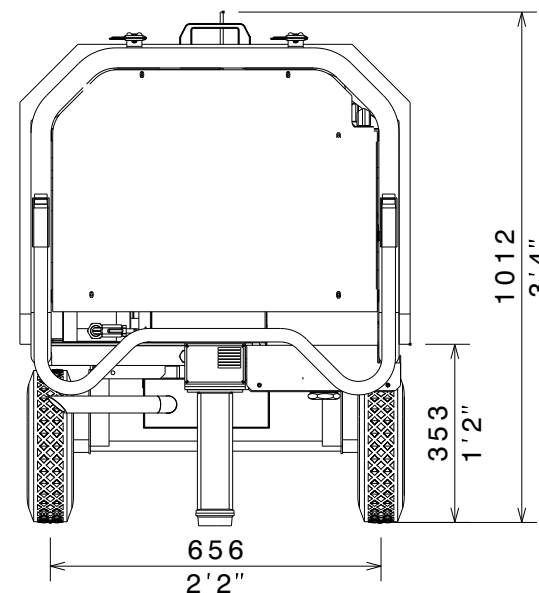
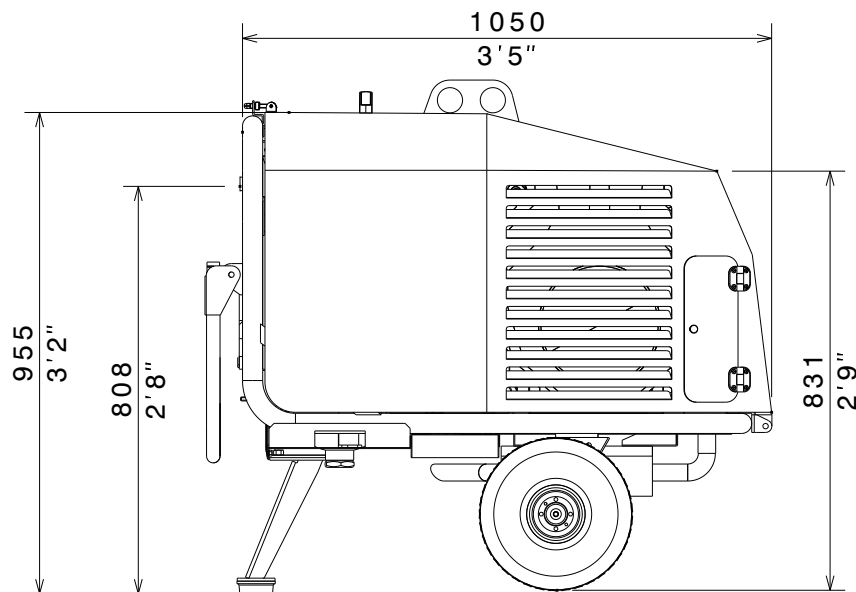
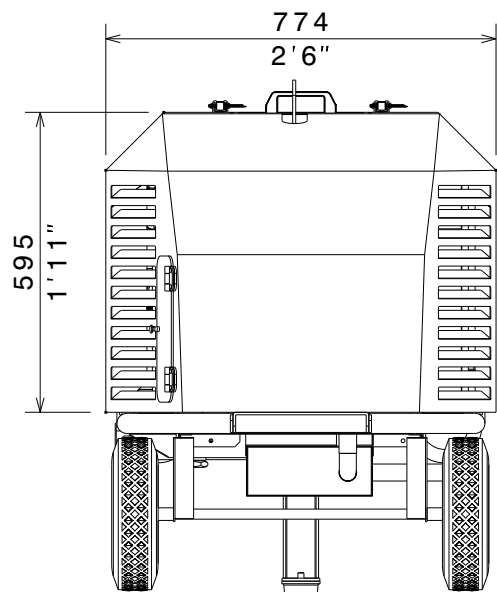

mm
Inches

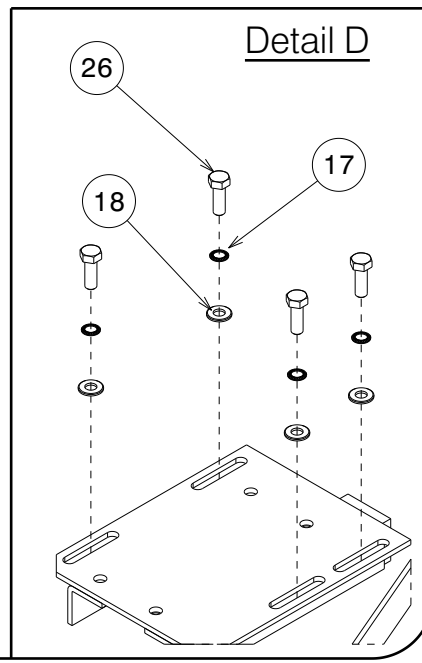
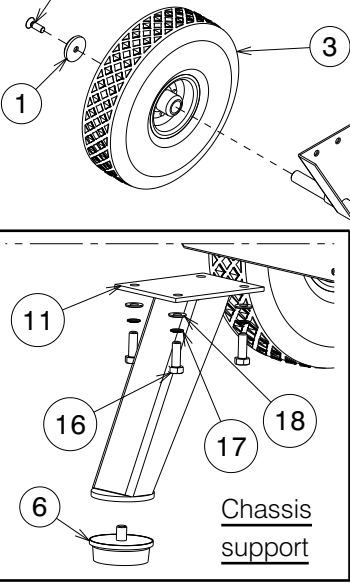
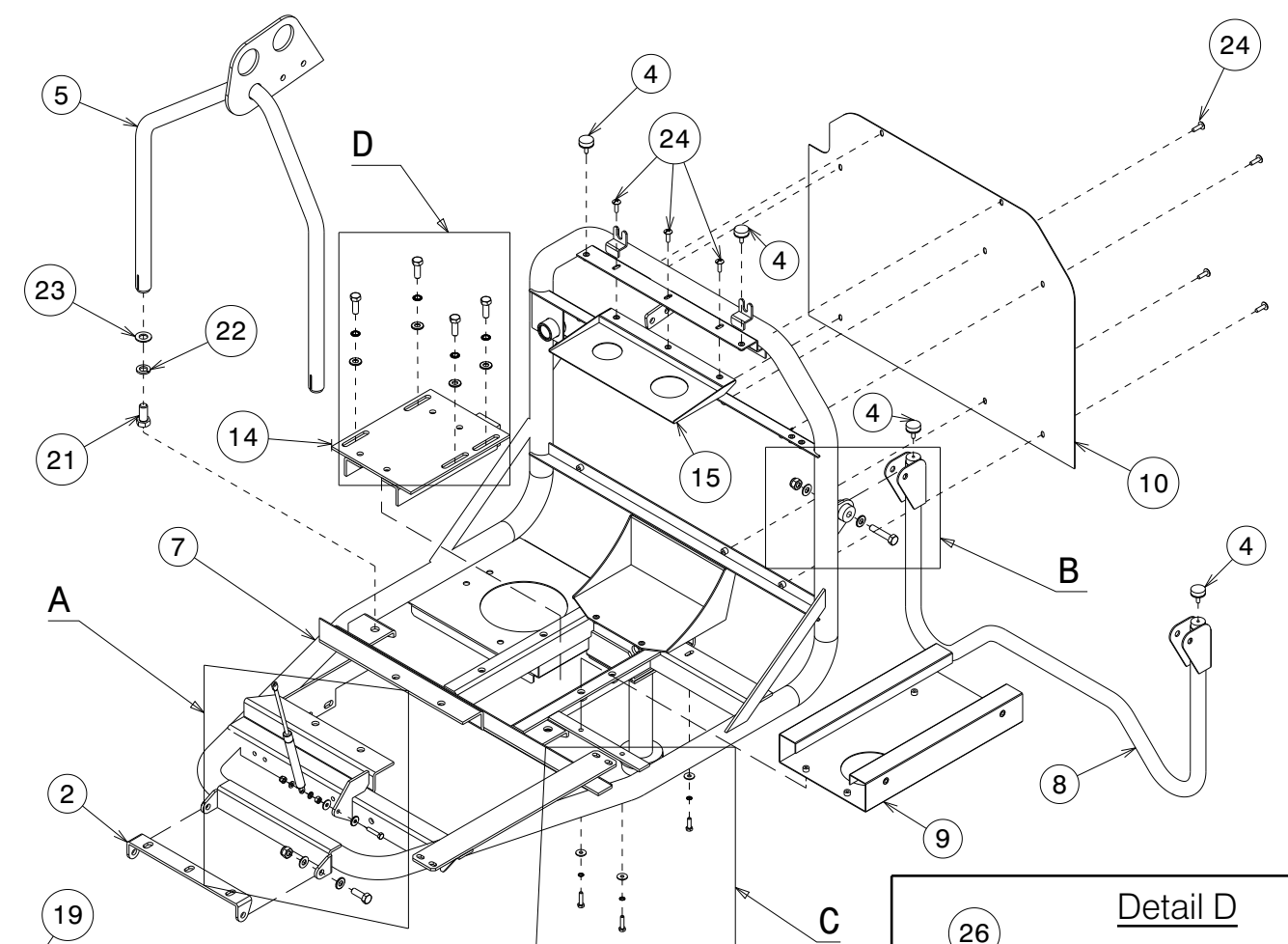
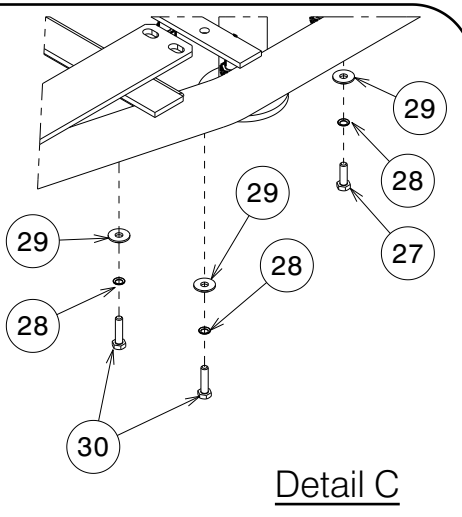
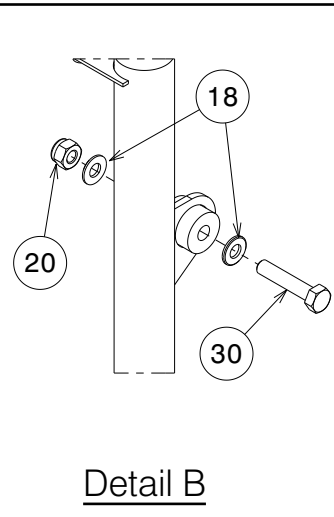
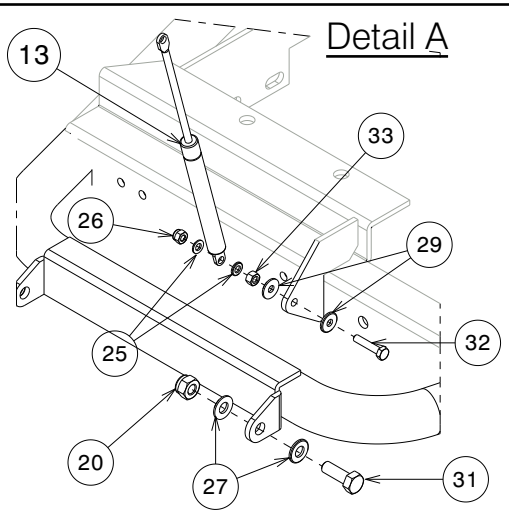

Motocompressor – GP 75

PARTS LEGENDA: Clampings to the chassis

Tab. 01.1

POSITION	DESCRIPTION	PART No.	QUANTITY
1	Washer	015-072-S	2
2	Canopy hinge	007-01160-S	1
3	Wheel	153-0182-S	2
4	Silent block	061-900-S	4
5	Hoisting hook	017-031602-S	1
6	Rubber pad	197-003-S	1
7	Chassis	038-419002-S	1
8	Tow handle	209-016541-S	1
9	Fuel tank box	029-05645-S	1
10	Back panel	124-055062-S	1
11	Chassis support	068-01321-S	1
12	Axle	026-032201-S	1
13	Lift piston	091-105-S	1
14	Air end support	027-023501-S	1
15	Control panel	040-033151-S	1
16	Hexagonal head screw M10x30 UNI 5739	132-143-S	14
17	Schnorr washer d.10	015-252-S	4
18	Flat washer 10,2x21x2	015-032-S	20
19	Hexagon socket countersunk head 10x20 UNI 5933	146-151-S	2
20	Self-locking nut M10	137-050-S	8
21	Hex head screw M14x30	132-242-S	2
22	Elastic washer d.14	139-070-S	2
23	Washer Diam. 15 x 28 x 2,5	015-036-S	2
24	Large head screw M6x20	243-010-S	11
25	Flat washer 6,6x12x1,5 DIN125/1	015-027-S	2
26	Hex nut M6 UNI 7473	137-030-S	1
27	Hex head screw . M6x20	132-063-S	1
28	Washer d.6	015-250-S	1
29	Washer d. 6.6x18x2	015-029-S	5
30	Hex head screw screw M6x25 UNI 5739	132-065-S	2
31	Hexagonal head Screw M10x50 UNI 5739	132-147-S	2
32	Hexagonal head Screw M6x30 UNI 5739	132-066-S	1
33	Hex nut M6 UNI 5587	135-030-S	1

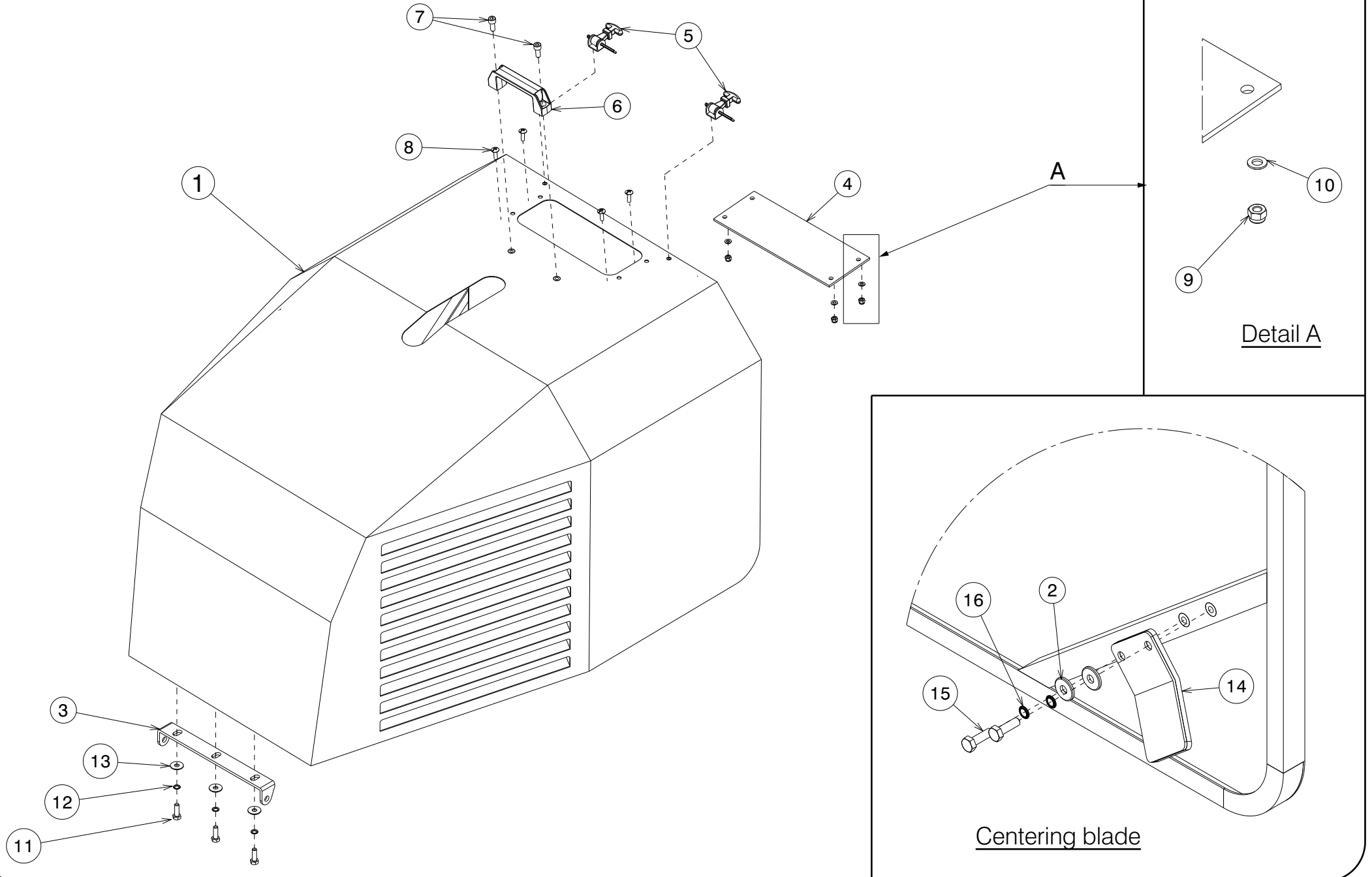

Motocompressor – GP 75

PARTS LEGENDA: Canopy

Tab. 01.2

POSITION	DESCRIPTION	PART No.	QUANTITY
1	Canopy	036-150502-S	1
2	Washer d. 6.6x18x2	015-029-S	2
3	Canopy hinge	007-01160-S	1
4	Plexiglass panel	057-022501-S	1
5	Rubber tie-rod	112-0065-S	2
6	Handle	209-009-S	1
7	Hex socket head cap screw M8x20	133-132-S	2
8	Large head screw M6x20	243-010-S	4
9	Hex nut M6 UNI 7473	137-030-S	4
10	Flat washer 6,6x12x1,5 DIN125/1	015-027-S	4
11	Hex head screw M8x25 UNI 5739	132-102-S	3
12	Schnorr washer d.8	015-251-S	3
13	Flat washer 8x24x2 UNI6593	015-031-S	3
14	Centering blade	120-039522-S	1
15	Hex head screw . M6x20	132-063-S	2
16	Washer d.6	015-250-S	2

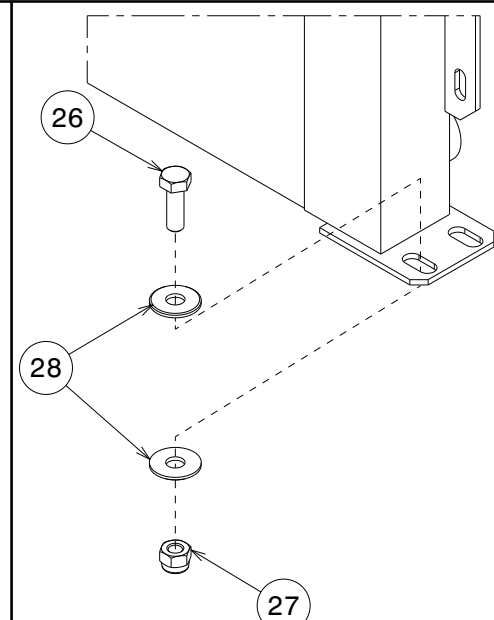
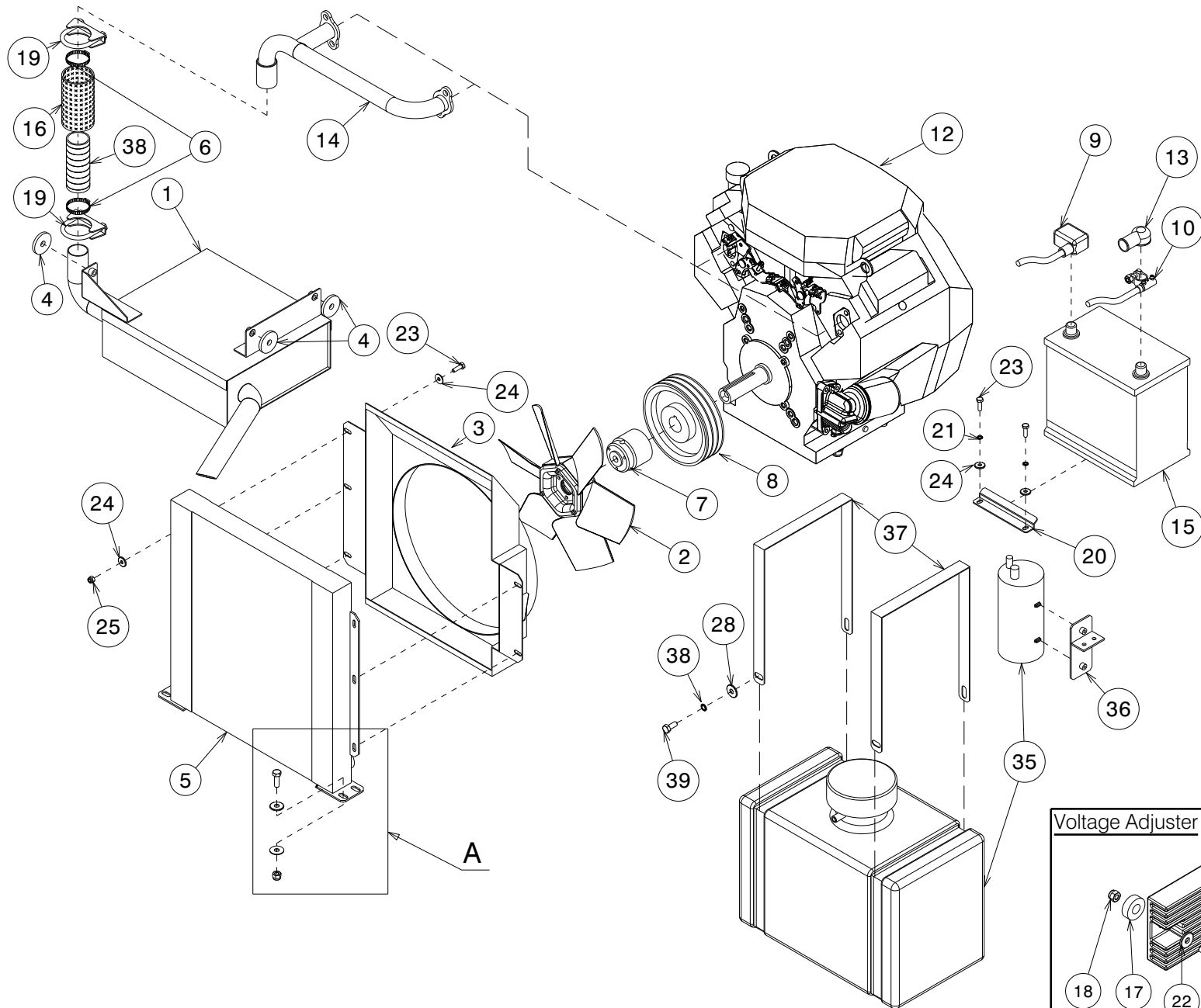

Detail A

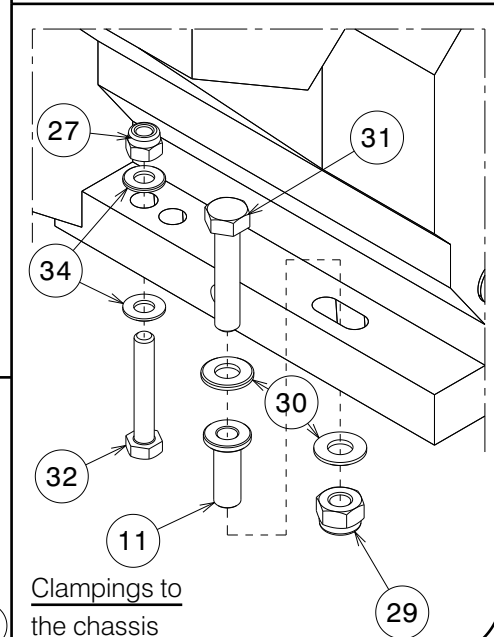

Clampings to the chassis

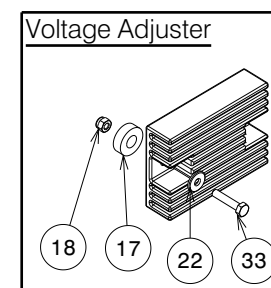

Motocompressor – GP 75

PARTS LEGENDA: Engine – Radiator – Fuel tank

Tab. 02

POSITION	DESCRIPTION	PART No.	QUANTITY
1	Muffler	042-063552-S	1
2	Fan	083-09722-S	1
3	Fan-cover	001-1482061-S	1
4	Seal for muffler d.40	023-077-S	3
5	Radiator	011-062452-S	1
6	Pipe clamp d. 25-40	149-022-S	2
7	Fan support	028-084652-S	1
8	Engine pulley	050-48870-S	1
9	Positive battery cable L=1270	252-054-S	1
10	Negative battery cable	252-056-S	1
11	Fixing bush	223-0386-S	2
12	Engine	165-375-S	1
13	Rubber plug	284-030-S	1
14	Collector	119-0326505-S	1
15	Battery	174-901-S	1
16	Fiberglass braiding	097-030-G	1
17	Spacer	009-087.5-S	2
18	Hex nut M6 UNI 7473	137-030-S	2
19	Clamp	149-051-S	2
20	Battery fastener	115-009-S	1
21	Washer d.6	015-250-S	2
22	Washer d. 6.6x18x2	015-029-S	2
23	Hex head screw . M6x20	132-063-S	8
24	Washer d. 6.6x18x2	015-029-S	14
25	Hex nut M6 UNI 7473	137-030-S	8
26	Hex head screw M8x25 UNI 5739	132-102-S	4
27	Self locking nut M8 UNI 7473	137-040-S	6
28	Flat washer 8x24x2 UNI6593	015-031-S	12
29	Self-locking nut M10	137-050-S	2
30	Flat washer 10,2x21x2	015-032-S	4
31	Hexagonal head Screw M10x50 UNI 5739	132-147-S	2
32	Hexagonal head Screw M8x50 UNI 5739	132-107-S	2
33	Hexagonal head Screw M6x30 UNI 5739	132-066-S	2
34	Flat washer 8,4x17x1,5 UNI 6592	015-030-S	4
35	Fuel tank + Carbo-canister (EPA-CARB)	201-0151-S	1
36	Carbo-canister support blade	120-31063-S	1
37	Fuel tank clamping blade	120-3105-S	2
38	Schnorr washer d.8	015-251-S	4
39	Hex head screw M8x20 UNI 5739	132-1010-S	4

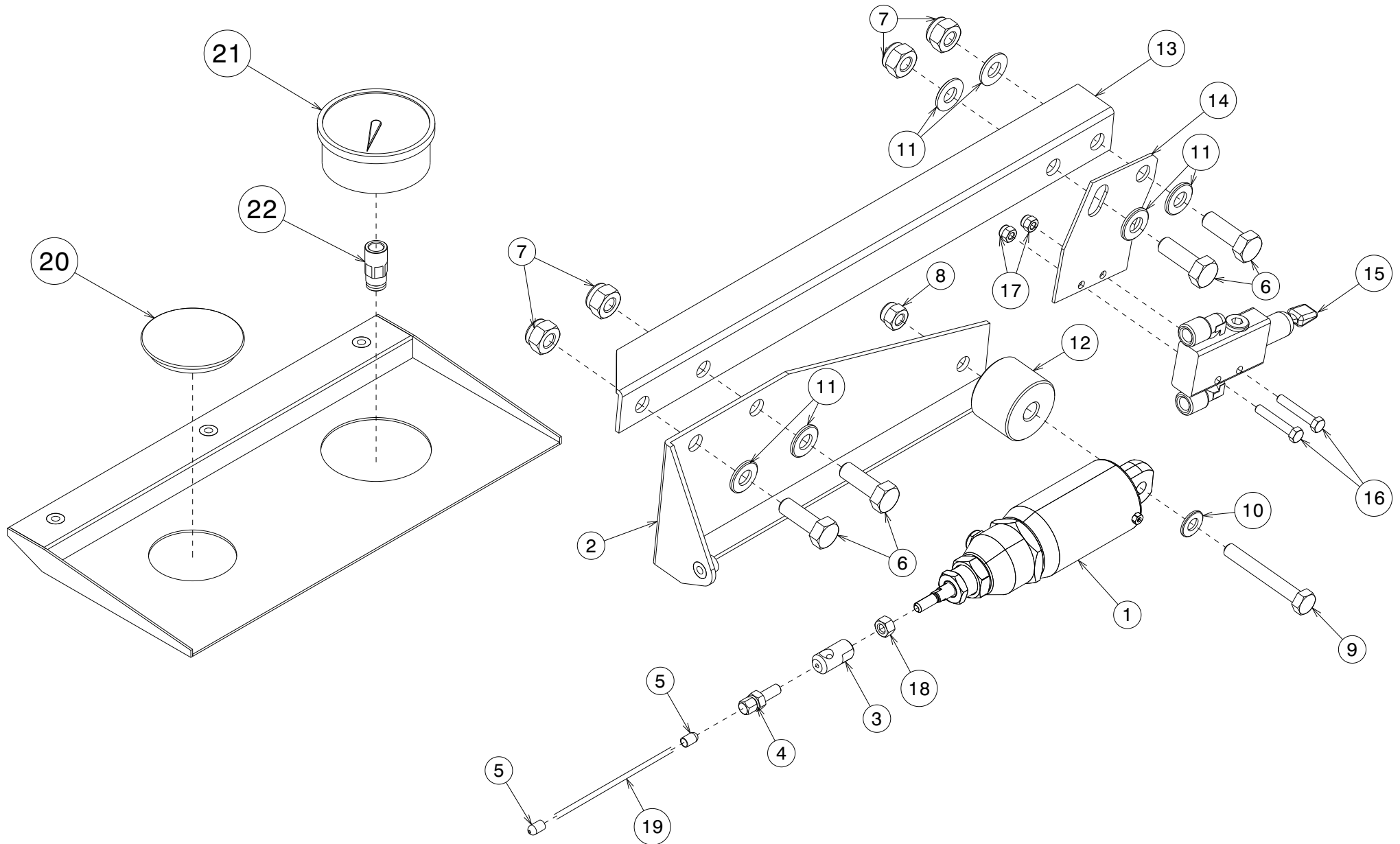

Motocompressor – GP 75

PARTS LEGENDA: Accelerator piston – Start-Work valve

Tab. 02.1

POSITION	DESCRIPTION	PART No.	QUANTITY
1	Accelerator piston assembly	044-0040516-S	1
2	Accelerator piston support	010-105303-S	1
3	Throttle cable fixing bush	223-51107-S	1
4	Manual accelerator clamp	288-901-S	1
5	Sheath stopper bush	959-002-S	2
6	Hexagonal head screw M10x30 UNI 5739	132-143-S	4
7	Self-locking nut M10	137-050-S	4
8	Self locking nut M8 UNI 7473	137-040-S	1
9	Hexagonal head screw M8x60 UNI 5739	132-109-S	1
10	Flat washer 8,4x17x1,5 UNI 6592	015-030-S	1
11	Flat washer 10,2x21x2	015-032-S	6
12	Spacer	009-032-S	1
13	Hoisting hook clamping blade	120-308301-S	1
14	Start/Work valve support blade	120-21722-S	1
15	Valve for low pressure starting	033-029-S	1
16	Hexagonal head screw M5x30 UNI 5739	132-042-S	2
17	Self locking nut M8 UNI 7473	137-020-S	2
18	Hex nut M6 UNI 5587	135-030-S	1
19	Throttle cable	960-0171-S	55 in
20	Plastic plug	106-37913-S	1
21	15 Bar pressure gauge	206-020-S	1
22	Straight quick coupling F (1/8") for pipe d.6	148-5765-S	1

Belts

Tab. 03

GP 75 - Air End

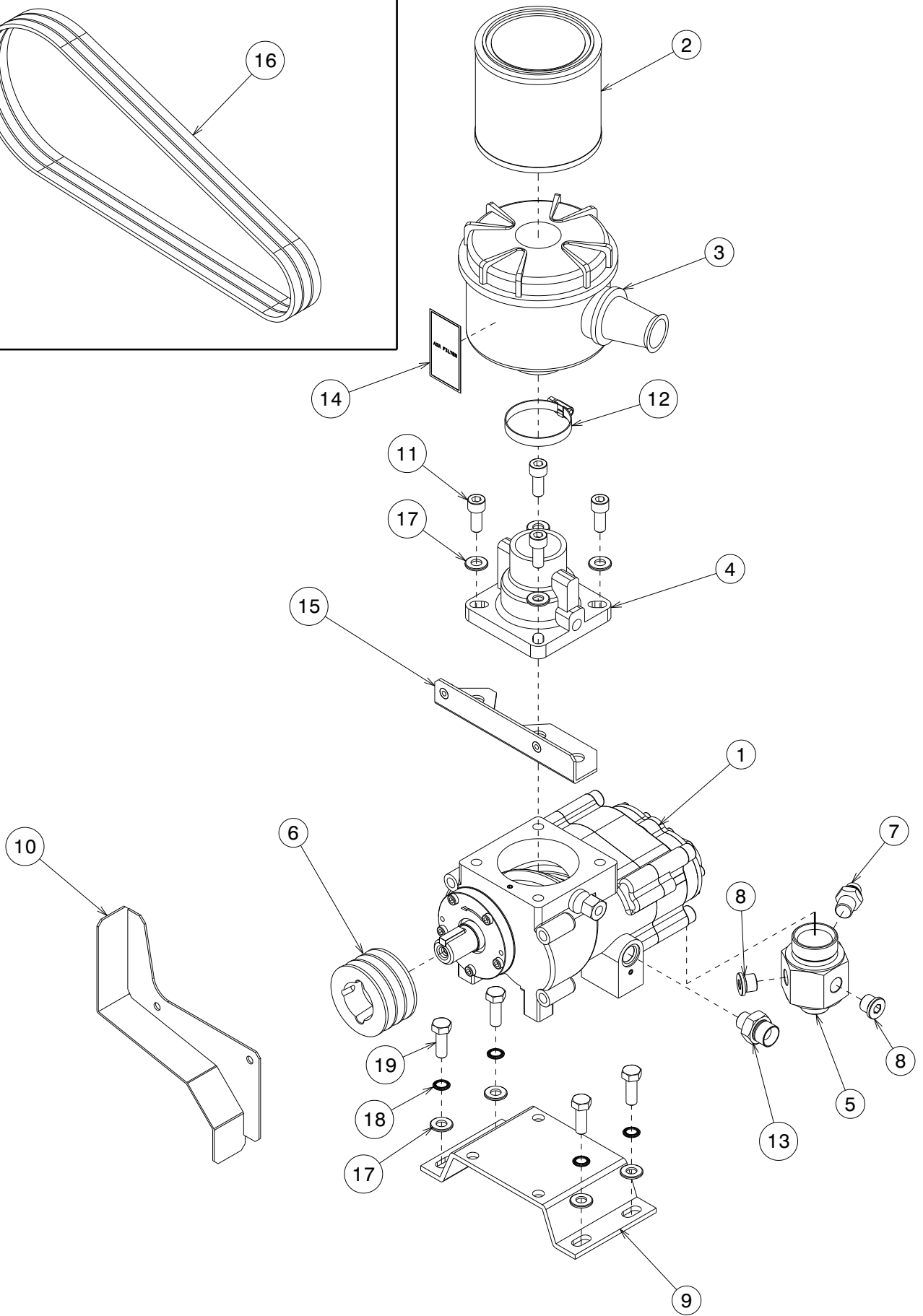
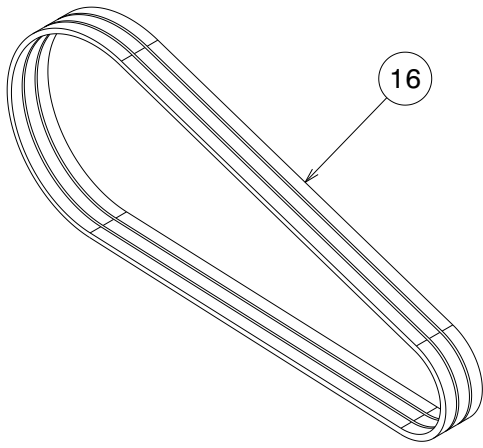

Motocompressor – GP 75

PARTS LEGENDA: Air end

Tab. 03

POSITION	DESCRIPTION	PART No.	QUANTITY
1	Air end	024-03290730-F	1
2	Air filter	162-762-F	1
3	Compressor air filter group	014-4114-S	1
4	Inlet valve assembly	024-138151-S	1
5	Delivery flange	004-0692-S	1
6	Pulley	050-490710-S	1
7	Compressor thermo contact125°	103-0125-S	1
8	Hexagonal head plug	106-094-S	2
9	Air end clamping blade	120-21720-S	1
10	Belts protection panel	124-05510-S	1
11	Hex socket head cap screw M10x25	133-182-S	4
12	Pipe clamp d.40x60	149-135-S	1
13	Double screw d.1"	187-038-S	1
14	Satiny air filter sticker	238-001-S	1
15	Belts protection panel support	010-163480-S	1
16	Belts	156-413082-S	3
17	Flat washer 10,2x21x2	015-032-S	8
18	Schnorr washer d.10	015-252-S	4
19	Hexagonal head screw M10x30 UNI 5739	132-143-S	4

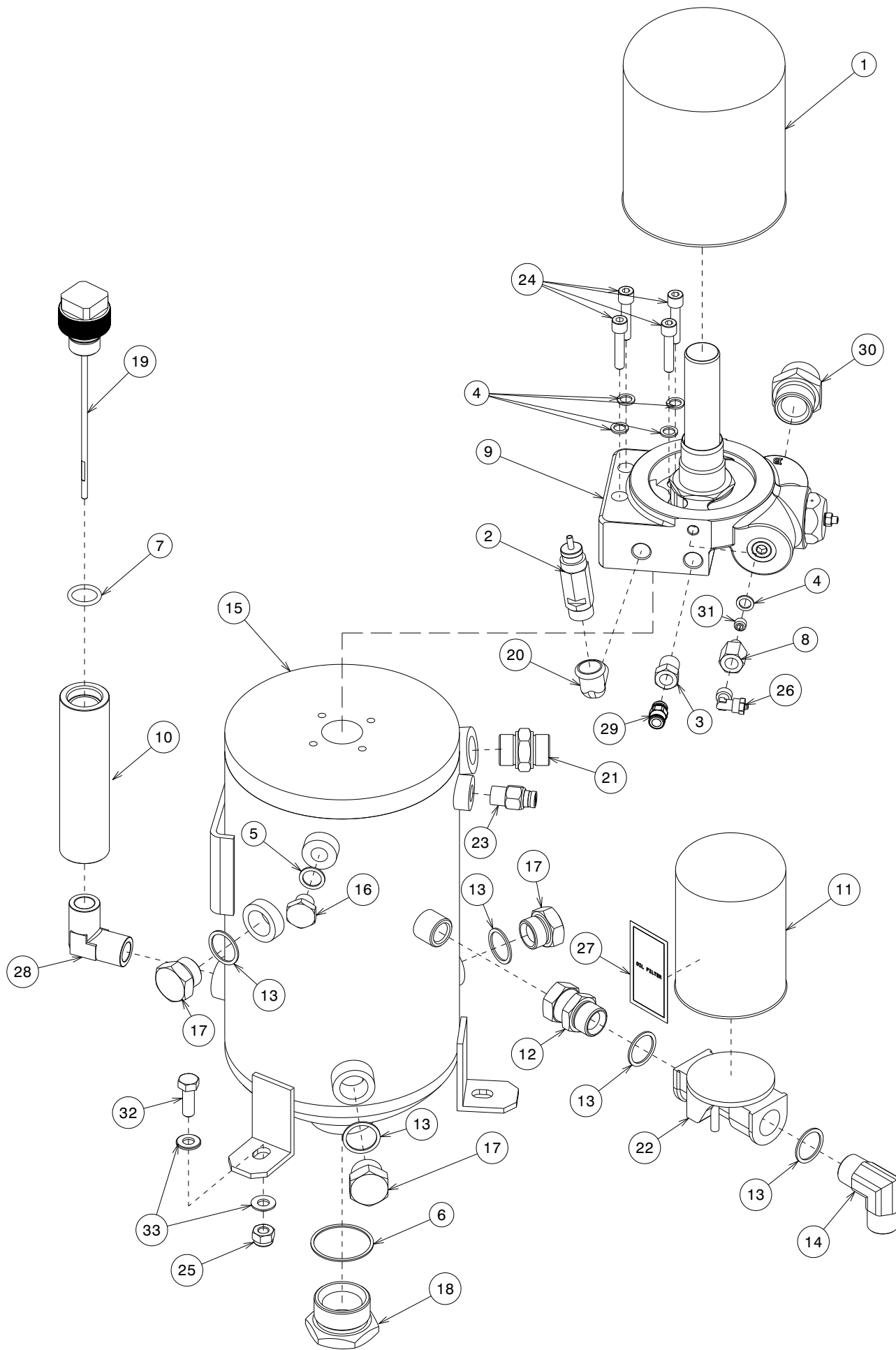

Motocompressor – GP 75

PARTS LEGENDA: Separator tank

Tab. 03.1

POSITION	DESCRIPTION	PART No.	QUANTITY
1	Separator filter	157-170-S	1
2	Safety valve (1/2") ASME	033-059-S	1
3	Reduction 3/8 M conical to 1/4F	190-020-S	1
4	Copper washer (1/8")	015-005-S	5
5	Copper washer (d. 16.2x22x1.5)	015-009-S	1
6	Copper washer (1 1/2")	015-019.1-S	1
7	OR seal	023-026.5-S	1
8	Extension F+M L=30 (1/4" – 1/8")	189-302-S	1
9	Valve assembly	024-021534-F	1
10	Oil sleeve	063-1205-S	1
11	Compressor oil filter	099-007-S	1
12	Straight adapter coupling M+f gir. 3/4	148-005-S	1
13	Copper washer (3/4")	015-015-S	5
14	Straight quick coupling (3/4")	148-287.3-S	1
15	Tank	037-00101-S	1
16	Iron plug (M16x1.5)	106-100-S	1
17	Iron plug (3/4")	106-130-S	3
18	Male hexagonal head iron plug (1" 1/2)	106-137-S	1
19	Oil level rod plug	106-01060-S	1
20	Short radius elbow M 3/8 + F 1/2	111-026-S	1
21	Double screw 3/4" hole 19,1 Din standard	187-060-S	1
22	Oil compressor filter support	010-0475-S	1
23	115' compressor thermo contact	103-008-S	1
24	Hex socket head cap screw M 8x 40	133-136-S	4
25	Self-locking nut M10	137-050-S	3
26	Fitting 90' (1/4") for pipe d. 6	148-090-S	1
27	Satiny oil filter sticker	238-002-S	1
28	Conical 90' M+M adapter coupling (3/4")	148-287.35-S	1
29	Straight quick coupling (1/4") per tubo d.8	148-575-S	1
30	Double screw (1")	187-070-S	1
31	Grub screw (1/8")	218-0012-S	1
32	Hexagonal head screw M10x30 UNI 5739	132-143-S	3
33	Flat washer 10,2x21x2	015-032-S	3

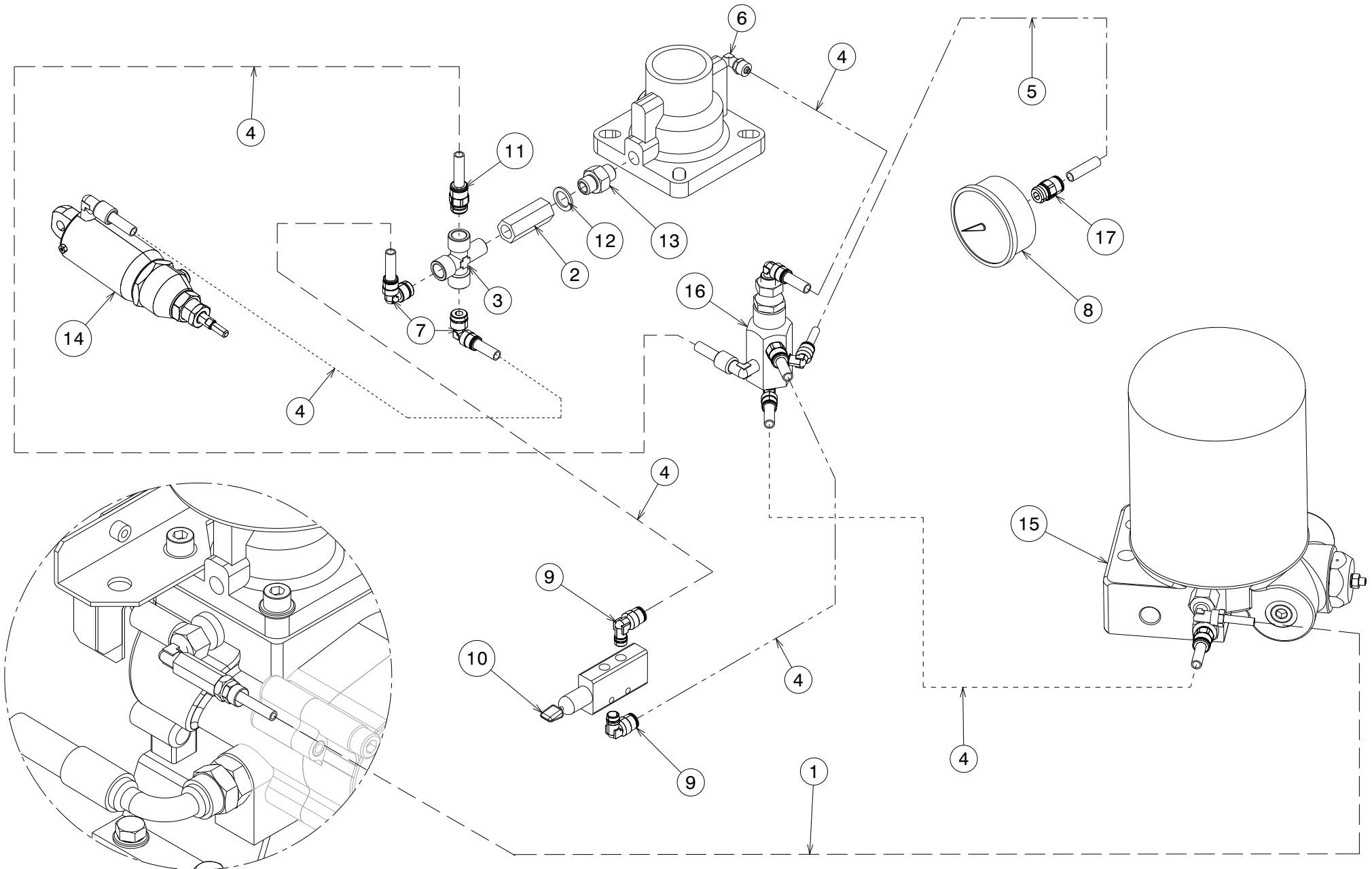

Motocompressor – GP 75

PARTS LEGENDA: Pneumatic system

Tab. 04

POSITION	DESCRIPTION	PART No.	QUANTITY
1	Polyamidis pipe 6x4	089-060-S	1
2	Non return valve (1/4")	033-017-S	1
3	Cross fitting 1M 1/4 + 3F 1/4	148-193-S	1
4	Rilsan blue pipe 8x6	089-0705-S	6
5	Rilsan blue pipe 6x4	089-0605-S	1
6	Elbow joint (1/8") for pipe d.6	148-080-S	1
7	Quick coupling 90° (1/4") per tubo d.8	148-573.5-S	2
8	15 Bar pressure gauge	206-020-S	1
9	Pressure regulation valve assembly	024-0325-F	1
10	Straight quick coupling F (1/8") for pipe d.6	148-5765-S	1
11	Straight quick coupling (1/4") per tubo d.8	148-575-S	1
12	Copper washer (1/4")	015-007-S	1
13	Double screw 1/4 cil.-1/4 con. hole 7	187-006-S	1
14	Accelerator piston assembly	044-0040516-S	1
15	Minimum pressure valve	024-021534-S	1

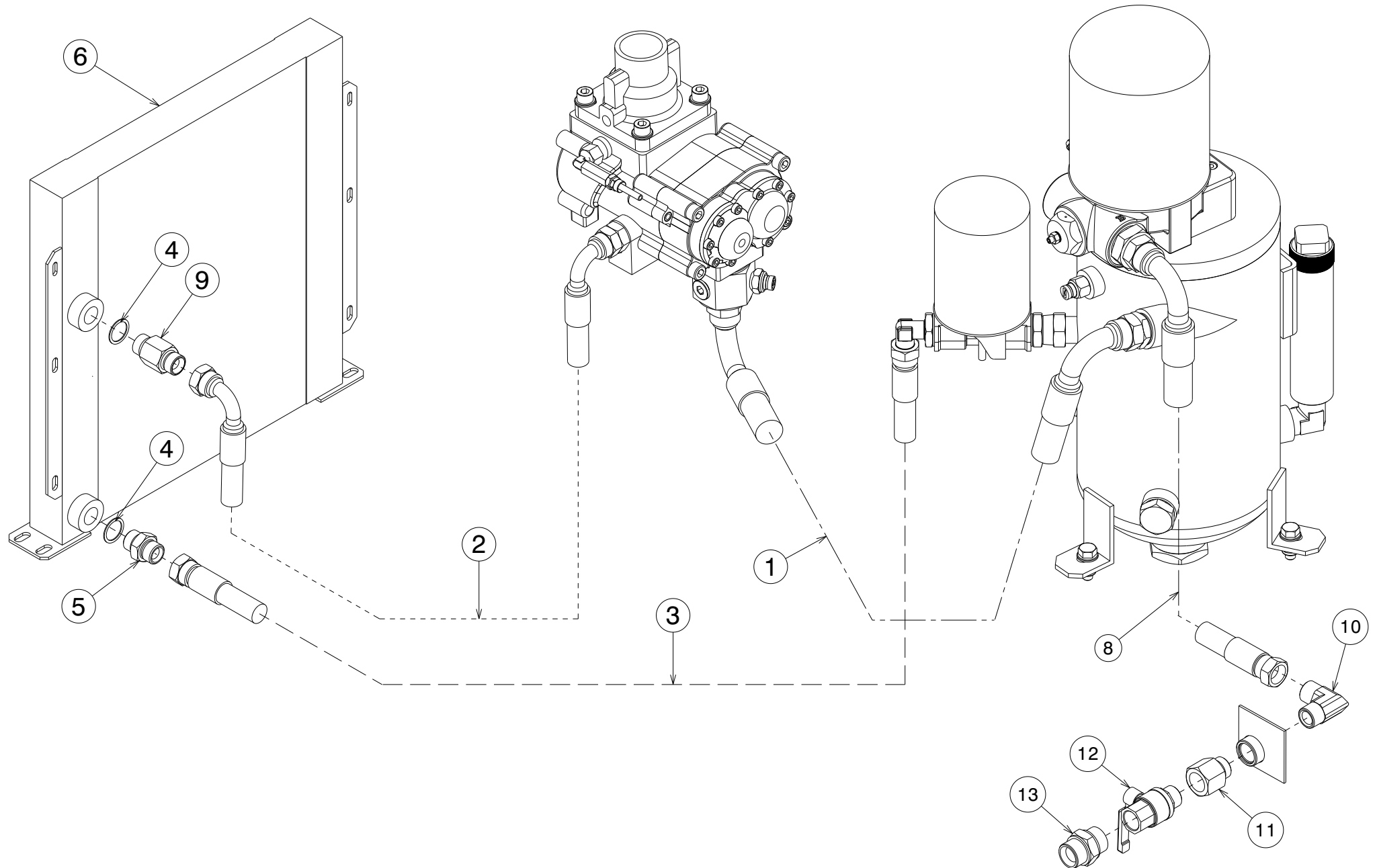

Motocompressor – GP 75

PARTS LEGENDA: Piping system

Tab. 05

POSITION	DESCRIPTION	CODE	QUANTITY
1	Piping 3/4"	065-740.80-S	1
2	Piping 1/2"	065-686.0561-S	1
3	Piping 1/2"	065-126.4-S	1
4	Copper washer (1/2")	015-012-S	2
5	Double screw (1/2" foro 12.6)	187-045-S	1
6	Radiator	011-062452-S	1
7	Adapter fitting 90° M+M (1/2")	148-287.5-S	1
8	Piping 3/4"	065-779.980-S	1
9	Extension	189-1025-S	1
10	Straight quick coupling (3/4")	148-287.3-S	1
11	Extension 3/4" M A 3/4" F L=45	189-054-S	1
12	Ball valve connection M+F (3/4")	152-030-S	1
13	Double screw (3/4")	187-060-S	1

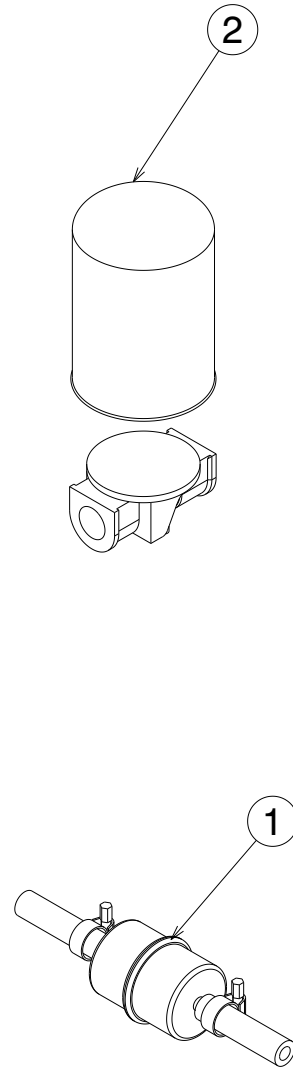
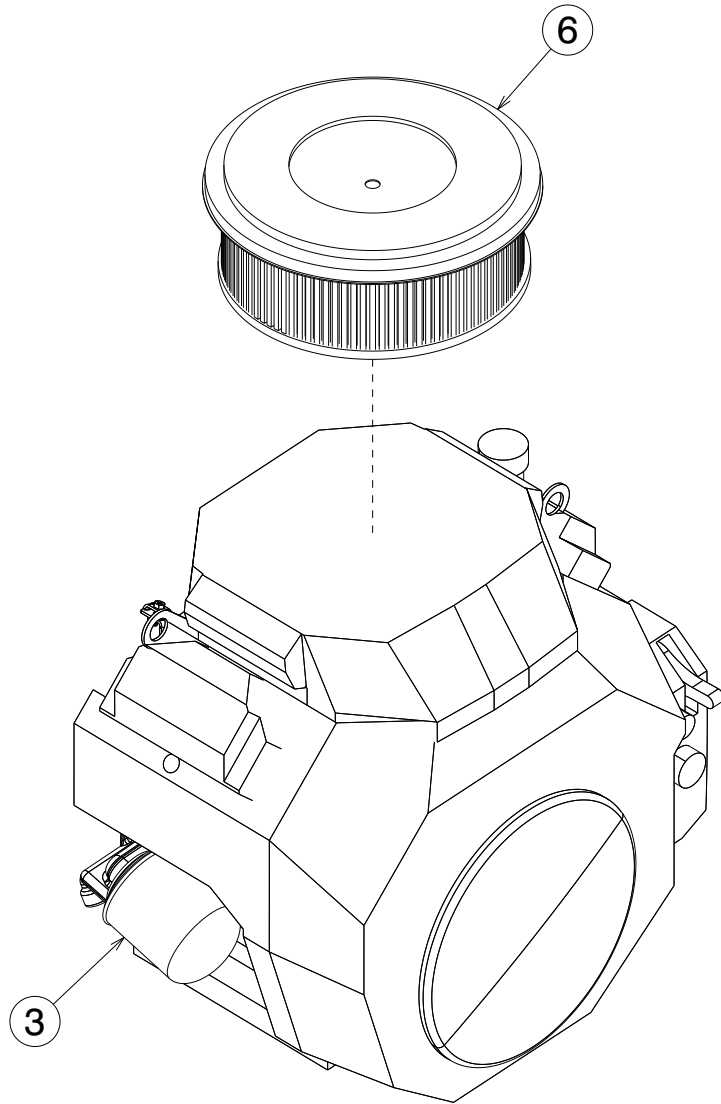
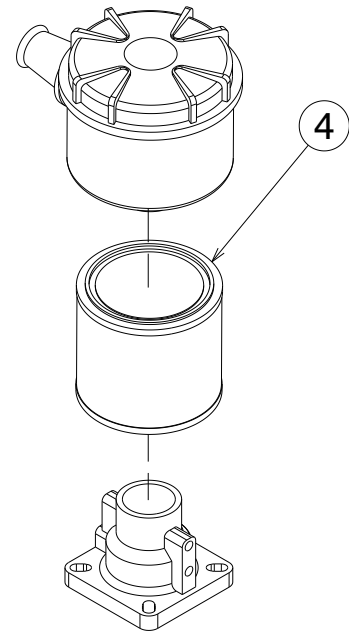
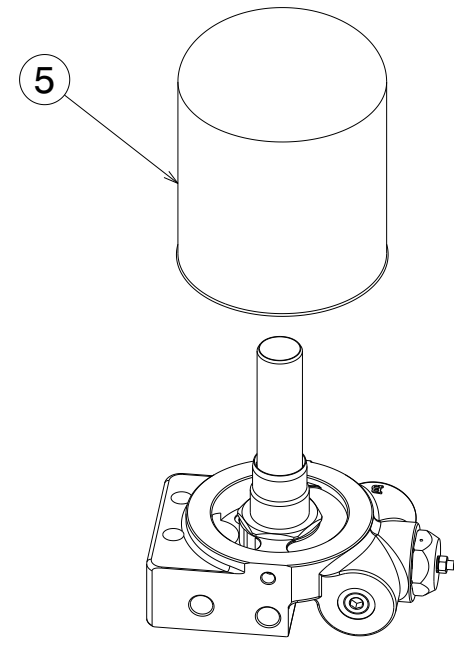

Motocompressor – GP 75

PARTS LEGENDA: Filters

Tab. 06

POSITION	DESCRIPTION	PART No.	QUANTITY
1	Fuel filter	191-150-S	1
2	Compressor oil filter	099-007-S	1
	Compressor oil filter P≥10 bar	099-012-S	1
3	Engine oil filter	099-031-S	1
4	Air filter	162-762-S	1
5	Separator filter	157-170-S	1
6	Air filter	162-0165-S	1

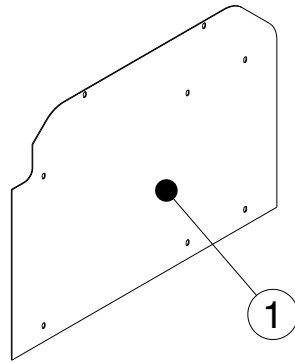
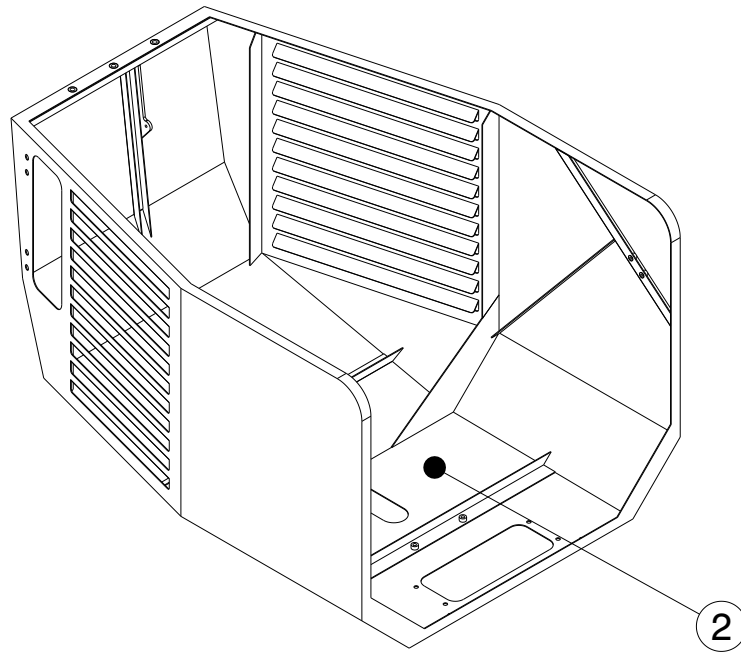

Motocompressor – GP 75

PARTS LEGENDA: Suondproofing kit

Tab. 07

POSITION	DESCRIPTION	PART No.	QUANTITY
1	Rear panel soundproofing kit	204-321242-S	1
2	Canopy soundproofing kit	204-3212401-S	1

