

FREEMAN

FREEMAN

MODEL: PBR50Q

18 GA. 2" BRAD NAILER

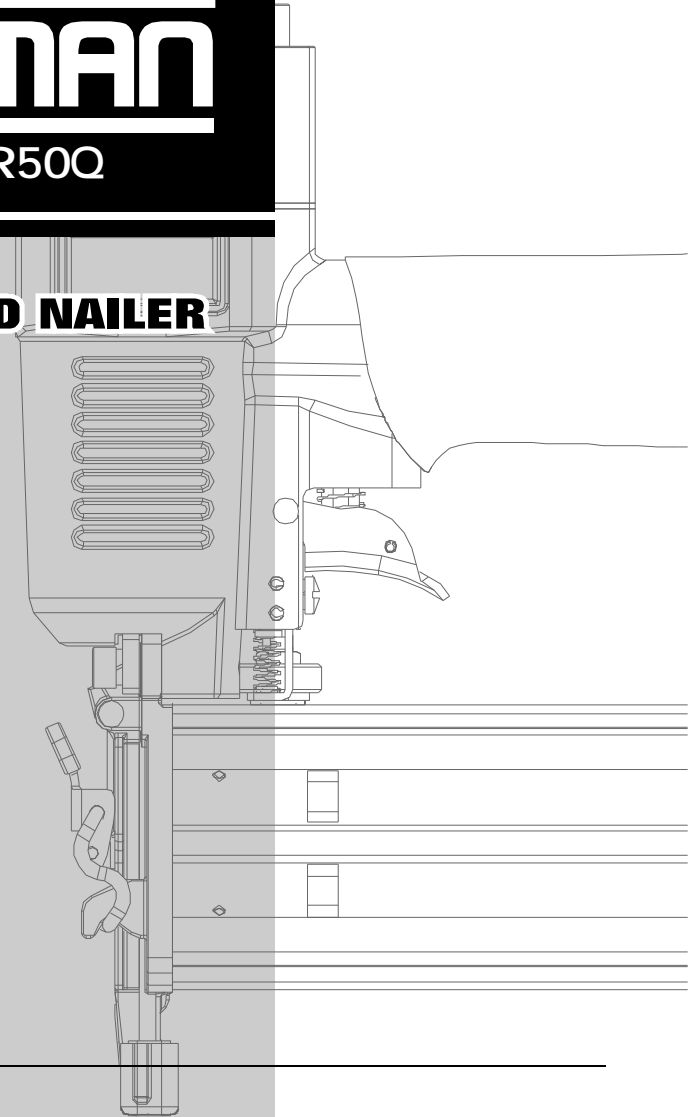

- [HTTP://WWW.FREEMANTOOLS.COM](http://www.freemantools.com)
- 1-888-669-5672
- PRIME GLOBAL PRODUCTS, INC.



WARNING:

Failure to follow warnings could result in DEATH OR SERIOUS INJURY.

- [HTTP://WWW.FREEMANTOOLS.COM](http://www.freemantools.com)
- 1-888-669-5672
- PRIME GLOBAL PRODUCTS, INC.
- 201 ROPE MILL PARKWAY WOODSTOCK, GA. 30188

SAVE THIS MANUAL FOR FUTURE REFERENCE

GENERAL SAFETY RULES	P3
UNPACKING	P6
FEATURES	P7
OPERATION	
USING BELT HOOK	P7
ADJUSTING THE EXHAUST	P7
LOADING FASTENERS	P7
UNLOADING FASTENERS	P8
CLEARING JAMS	P8
NON-MARRING PAD	P8
SETTING THE AIR PRESSURE	P8
DEPTH ADJUSTMENT	P9
FIRING THE TOOL	P9
WORK CONTACT ELEMENT (WCE)	P9
MAINTENANCE	P9
RECOMMENDED HOOKUP	P10
TROUBLE SHOOTING	P11
WEARING PARTS	P11
WARRANTIES	P11

WARNING:

The warnings and precautions discussed in the manual cannot cover all possible conditions and situations that may occur. It must be understood by the user that common sense and caution are factors which cannot be built into this product, but must be supplied by the user.

SAVE THIS MANUAL

- Keep this manual for the safety warnings, precautions, operations, inspections and maintenance. Keep this manual and the receipt in a safe and dry place for future reference.

WARNING:

To avoid serious personal injury, do not attempt to use this product until you read the manual thoroughly and understand it completely. Save this manual and review frequently for continuing safe operation and instructing others who may use this tool.

SYMBOLS

- In this manual, on the labels, packages and all other information provided with this tool. The following signal words and meanings are intended to explain the levels of risk associated with this tool.

SYMBOLS	SIGNAL	MEANING
	WARNING:	Indicates a potentially hazardous situation, which, if not avoided, could result in death or serious injury.
	CAUTION:	Indicates a potentially hazardous situation, which, if not avoided, may result in minor or moderate injury.
	CAUTION:	(Without symbol) Indicates a situation that may result in property damage.

GENERAL SAFETY RULES

INSTRUCTIONS PERTAINING TO A RISK OF FIRE, ELECTRIC SHOCK, OR INJURY TO PERSONS

WARNING:

When using tools, basic precautions should always be followed, including the following:

CALIFORNIA PROPOSITION 65

WARNING:

This product or its power cord may contain chemicals known to the State of California to cause cancer and birth defects or other reproductive harm. Wash hands after handling.

WORK AREA

- Keep the work area clean and well lighted. Cluttered benches and dark areas increase the risks of accidents.
- Do not operate the tool in explosive atmospheres, such as in the presence of flammable liquids, gases, or dust. The tool creates a spark which may ignite flammable liquids, gases or dust.
- Keep bystanders, children, and others away while operating the tool. Distractions could result in improper use and cause injury.
- Avoid unintentional misfires. Always use caution to avoid accidentally firing. Do not point towards yourself or anyone whether it contains fasteners or not.

PERSONAL SAFETY

- Do not nail on top of another nail. This is able to cause the nail to be deflected and hit

someone, or cause the tool to react and result in a risk of injury to persons.

- Remove finger from the trigger when not driving fasteners. Never carry the tool with finger on trigger, the tool is able to fire a fastener.
- Always wear eye protection. Operator and others in the work area should always wear ANSI-approved safety goggles with side shields. Eye protection is used to guard against flying fasteners and debris, which may cause severe eye injury. You can use the goggles packed with the tool.
- Always wear hearing protection when using the tool. Prolonged exposure to high intensity noise may cause hearing loss.
- Use safety equipment. A dust mask, non-skid safety shoes and a hard hat must be used for the applicable conditions. Wear a full face shield if you are producing metal filings or wood chips.
- Dress properly. Do not wear loose clothing or jewelry. Contain long hair. Keep your hair, clothing, and gloves away from moving parts. Loose clothes, jewelry, or long hair can be caught in moving parts.
- Stay alert, watch what you are doing and use common sense when operating a power tool. Do not use tool while tired or under the influence of drugs, alcohol, or medication. A moment of inattention while operating the tool may cause serious injury.
- Avoid unintentional firing. Keep fingers away from trigger when not driving fasteners, especially when connecting the tool to the air supply.
- Keep proper footing and balance at all times. Proper footing and balance enables better control of the tool in unexpected situations.
- Do not use on a ladder or unstable supports. Stable footing on a solid surface enables better control of the tool in unexpected situations.

- Make sure the hose is free of obstructions or snags. Entangled or snarled hoses can cause loss of balance or footing and may become damaged, resulting in possible injury.
- Do not overreach. Keep proper footing and balance at all times. Proper footing and balance enables better control of the tool in unexpected situations.
- Do not attach the hose or tool to your body. Attach the hose to the structure to reduce the risk of loss of balance if the hose shifts.
- Always assume that the tool contains fasteners. Do not point the tool toward yourself or anyone whether it contains fasteners or not.
- Wash hands after handling. This product or its power cord may contain chemicals known to the State of California to cause cancer and birth defects or other reproductive harm.

TOOL USE AND CARE

- Know this tool. Read manual carefully, learn its applications and limitations, as well as the specific potential hazards related to this tool.
- Use only fasteners that are recommended for your models. Do not use the wrong fasteners or load the fasteners incorrectly.
- Check for misalignment or binding of moving parts, breakage of parts, and any other condition that may affect the tool's operation. If damaged, have the tool serviced before using. Many accidents are caused by poorly maintained tools.
- Maintain tools with care. Keep tool clean. A properly maintained tool, reduces the risk of binding and is easier to control.
- Store tools out of the reach of children and other untrained people. Tools are dangerous in the hands of untrained users.
- Check operation of the tool before use. Do not use the tool if the workpiece contact mechanism is not working correctly as accidental driving of a fastener may occur.
- Do not use tool if trigger does not actuate properly. Any tool that cannot be controlled with the trigger is dangerous and must be repaired.
- Do not force tool. Use the correct tool for your application. The correct tool will do the job better and safer at the rate for which it is designed.
- Use clamps or another practical way to secure and support the workpiece to a stable platform. Holding a tool by hand or against the body is unstable and may lead to loss of control.
- Keep the tool and its handle dry, clean and free from oil and grease. Always use a clean cloth when cleaning. Never use brake fluids, gasoline, petroleum-based products, or any strong solvents to clean your tool.
- Do not use the tool as a hammer.
- Never use this tool in a manner that could cause a fastener to be directed toward anything other than the workpiece.
- Never use gasoline or other flammable liquids to clean the tool. Never use the tool in the presence of flammable liquids or gases. Vapors could ignite by a spark and cause an explosion which will result in death or serious personal injury.
- Do not remove, tamper with, or otherwise cause the trigger lock or trigger to become inoperable. Do not operate any tool which has been modified in a like fashion. Death or serious personal injury could result.
- Do not touch the trigger unless driving fasteners. Never attach air line to tool or carry tool while touching the trigger. The tool could eject a fastener which will result in death or serious personal injury. Also actuate the trigger lock to the safe position when not in use.
- Always fit tool with a fitting or hose coupling on or near the tool in such a manner that all compressed air in the tool is discharged at the time the fitting or hose coupling is disconnected. Do not use a check valve or any other fitting which allows air to remain in the tool. Death or serious personal injury could occur.
- Never place hands or any other body parts in the fastener discharge area of the tool. The tool might eject a fastener and could result in death or serious personal injury.
- Never carry the tool by the air hose or pull the hose to move the tool or a compressor. Keep hoses away from heat, oil and sharp edges. Replace any hose that is damaged, weak or worn. Personal injury or tool damage could occur.
- Always assume the tool contains fasteners. Respect the tool as a working implement; no horseplay.
- Always keep others at a safe distance from the work area in case of accidental discharge of fasteners. Do not point the tool toward yourself or anyone whether it contains fasteners or not. Accidental triggering of the tool could result in death or serious personal injury.

- Do not drop or throw the tool. Dropping or throwing the tool can result in damage that will make the tool unusable or unsafe. If the tool has been dropped or thrown, examine the tool closely for bent, cracked or broken parts and air leaks. STOP and repair before using, or serious injury could occur.
- Avoid using the tool when the magazine is empty. Accelerated wear on the tool may occur.
- Clean and check all air supply hoses and fittings before connecting the tool to an air supply. Replace any damaged or worn hoses or fittings. Tool performance or durability may be reduced.
- Do not use the tool if it leaks air or does not function properly.
- Do not operate the tool if it does not contain a legible warning label.
- Always carry the tool by the handle. Never carry the tool by the air hose.
- Do not actuate the tool unless you intend to drive a fastener into the workpiece.
- Always handle the tool with care:
 - ◆ Respect the tool as a working implement.
 - ◆ Never engage in horseplay.
 - ◆ Never pull the trigger unless nose is directed toward the work.
 - ◆ Keep others a safe distance from the tool while tool is in operation as accidental actuation may occur, possibly causing injury.

AIR SUPPLY AND CONNECTIONS

- The connector on the tool must not hold pressure when air supply is disconnected. If an incorrect fitting is used, the tool can remain charged with air after disconnecting and thus will be able to drive a fastener even after the air line is disconnected, possibly causing injury.
- Do not use any type of reactive gases, including, but not limited to, oxygen and combustible gases, as a power source. Use filtered, lubricated, regulated compressed air only. Use of a reactive gas instead of compressed air may cause the tool to explode which will cause death or serious personal injury.
- Use only a pressure-regulated compressed air source to limit the air pressure supplied to the tool. The regulated pressure must not exceed 100 psi. If the regulator fails, the pressure delivered to the tool must not exceed 200 psi. The tool could explode which will cause death or serious personal injury.
- Always disconnect air resource:
 - ◆ Before unloading or making adjustments.
 - ◆ When maintaining the tool.
 - ◆ When clearing a jam.
 - ◆ When touching the safety yoke.
 - ◆ When tool is not in use.
 - ◆ When moving to a different work area.
 Such precautionary measures reduce the risk of injury to persons.

LOADING TOOL

- Do not load the tool with fasteners when any one of the operating controls is activated.
- Never place a hand or any part of body in fastener discharge area of tool.
- Never point tool at anyone.
- Do not pull the trigger or depress the workpiece contact as accidental actuation may occur, possibly causing injury.

TOOL SERVICE

- Use only accessories that are identified by the manufacturer for the specific tool model.
- Use of unauthorized parts or failure to follow maintenance instructions may create a risk of injury.
- Use only the lubricants supplied with the tool or specified by the manufacturer.
- Tool service must be performed only by qualified repair personnel.

OPERATION

- Do not drive fasteners near edge of material. The workpiece may split causing the fastener or ricochet, injuring you or people around.
- Do not carry the tool from place to place holding the trigger. Accidental discharge could result. Choice of triggering method is important. Check manual for triggering options.
- During normal use the tool will recoil immediately after driving a fastener. This is a normal function of the tool. Do not attempt to prevent the recoil by holding the tool against the work. Restriction to the recoil can result in a second fastener being driven from the tool. Grip the handle firmly and let the tool do the work. Failure to heed this warning can result in serious personal injury.
- Do not drive fasteners on top of other fasteners or with the tool at an overly steep angle as this may cause deflection of fasteners which could cause injury.

⚠ WARNING:

The warnings and precautions discussed above cannot cover all possible conditions and situations that may occur. It must be understood by the user that common sense and caution are factors which cannot be built into this product, but must be supplied by the user.

UNPACKING

- This tool has been shipped completely assembled.
- Make sure that all items listed in the packing list are included.
- Carefully remove the tool and any accessories from the box.
- Inspect the tool carefully to make sure no breakage or damage occurred during shipping.
- Do not discard the packing material until you have carefully inspected and satisfactorily operated the tool.
- If any parts are damaged or missing, please call 1-888-669-5672.

⚠ WARNING:

If any parts are missing do not operate this tool until the missing parts are replaced. Failure to do so could result in possible serious personal injury.

⚠ WARNING:

Do not attempt to modify this tool or create accessories not recommended for use with this tool. Any such alteration or modification is misuse and could result in hazardous condition leading to possible serious personal injury.

FEATURES

SPECIFICATIONS

REQUIRES: 5.87 SCFM with 100 fasteners per minute @ 90 psi
 AIR INLET: 1/4 inch NPT
 MAGAZINE CAPACITY: 100 fasteners, 18 gauge
 WEIGHT: 2.91 lbs
 MAXIMUM PRESSURE: 100 psi
 PRESSURE RANGE: 60 psi – 100 psi
 PIN SIZE RANGE: 3/8 inch to 2 inch

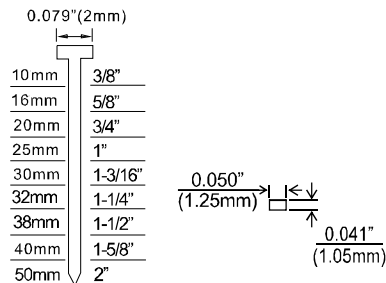

Compatible with all 18 Gauge Brad Nails.

FEATURES

- **360° ADJUSTABLE EXHAUST**
Allows user to direct air away from debris.
- **OIL-FREE DESIGN**
For less maintenance.
- **ANODIZED ALUMINUM CYLINDER AND MAGAZINE**
For long lasting durability.
- **COMFORT - GRIP HANDLE**
For increased comfort and control.
- **ERGONOMICALLY ENGINEERED BODY**
Rugged and Comfortable resulting in a light-weight tool great for extended use.
- **AIR FILTER**
Keeps interior components debris free, extending tool life.
- **ADJUSTABLE DEPTH**
Depth is easily adjustable for various applications.
- **QUICK-JAM RELEASE**
Allows for easy access clearing in the event of a jam.
- **NON-MARRING SAFETY CONTACT**
Eliminates damage to working surface.

OPERATION

USING BELT HOOK

The tool is packed with a separate hook system. Assemble the hook on the tool before using the hook. The hook can be positioned on both left and right sides.

1. Loosen and remove the hook screw and nut(A). Save the screw and nut for future use.
2. Position the hook in your preferred position. Using the longer screw packed with hook, fasten hook to tool.

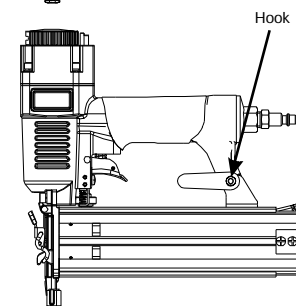
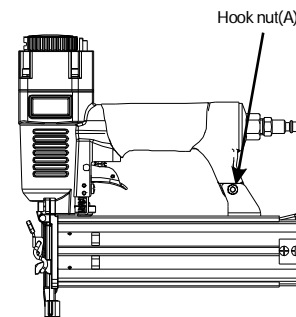

ADJUSTING THE EXHAUST

The adjustable exhaust on the cap of the tool allows users to direct the exhaust according to operator preference. To adjust the direction, turn the exhaust cap in the desired direction.

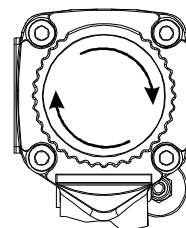

LOADING FASTENERS

1. Connect the tool to the air resource.
2. Push down on the latch button(B). Pull back on the magazine cover(C).
3. Insert a stick of fasteners into the magazine rail(D). Make sure the pointed ends of the fasteners are resting on the bottom ledge of the magazine when loading. Make sure the fasteners are not dirty or damaged.
4. Push the magazine cover(C) forward until latch button pops up.

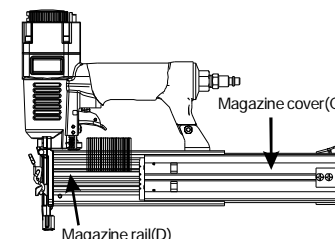
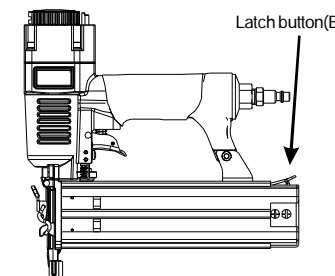

⚠ WARNING:

The tool may fire when it is first connected to the air resource. Always connect the tool to the air resource before loading fasteners to prevent injury from unintended cycling. Always make sure the tool's magazine is empty at the beginning of each work session, before connecting to an air resource.

⚠ WARNING:

Use only those fasteners recommended for use with this tool. Fasteners not identified for use with this tool by the tool manufacturer are able to result in a risk of injury to persons or tool damage when used in this tool.

⚠ WARNING:

Keep the tool pointed away from yourself and others when loading fasteners. Failure to do so could result in possible serious personal injury.

⚠ WARNING:

Never load fasteners with the workpiece contact or trigger activated. Doing so could result in possible serious personal injury.

UNLOADING FASTENERS

Unloading is the reverse of loading. Always disconnect the air resource before unloading.

⚠ WARNING:

Always unload all fasteners before removing tool from service.

⚠ WARNING:

Always disconnect the air resource before unloading.

CLEARING JAMS

Occasionally, a fastener may become jammed in the firing mechanism of the tool, making the tool inoperable. To remove a jammed fastener, follow the steps below:

1. Disconnect the tool from air resource.
2. Remove fasteners from the tool. Failure to do so will cause the fasteners to eject from the front of the tool.
3. Pull up on the latch (E) and open the jam release (F).
4. Using caution not to bend or damage the driver blade, using pliers or a screwdriver if required to clear the jammed fastener.
5. Close the jam release and latch.
6. Reconnect the tool to the air resource.
7. Reload the tool with fasteners.

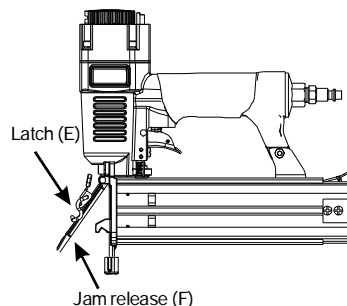

⚠ WARNING:

Make sure there is no fastener in magazine before clearing a jam.

⚠ WARNING:

Disconnect the tool from the air source whenever clearing a jam. After disconnecting the tool from the air compressor, there should still be enough air pressure to fire the tool. After the air hose is disconnected, always fire the tool into scrap wood repeatedly to make sure all of the compressed air is expended.

NON-MARRING PAD

The no-marring pad attached the nose of the tool helps prevent marring and denting when working with softer woods.

⚠ WARNING:

Disconnect the tool from the air source before removing or replacing the no-marring pad. Failure to do so could result in serious personal injury.

SETTING THE AIR PRESSURE

The amount of air pressure required depends on the size of the fasteners and the workpiece material. Begin testing the depth of drive by driving a test nail into the same type of workpiece material used for the actual job. Drive a test fastener with the air pressure set at 90-95psi. Raise or lower the air pressure to find the lowest setting that will perform the job with consistent results. It may be possible to achieve the desired depth with air pressure adjustments alone.

DEPTH ADJUSTMENT

The driving depth of the fasteners are adjustable. To adjust the depth, use the drive depth adjustment wheel (G) on the right side of the tool.

1. Disconnect the tool from air resource.
2. Turn the depth wheel left or right to change the driving depth.
3. Reconnect the tool to the air resource.
4. Drive a test nail after each adjustment until the desired depth is set.

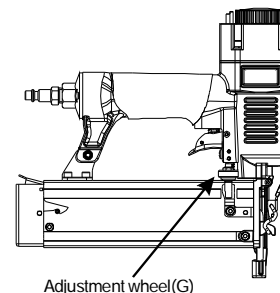

CAUTION:

It is advisable to test the depth on a scrap workpiece to determine the required depth for the application. To determine depth of drive, first adjust the air pressure and drive a test fastener. Never exceed 120psi.

FIRING THE TOOL

The tool is specially designed for single sequential mode. This mode requires the trigger to be pulled each time a fastener is driven. The tool can be actuated by depressing the WCE against the work surface followed pulling the trigger.

The trigger must be released to reset the tool before

⚠ WARNING:

Always know the operational mode of the tool before using. Failure to know the operational mode could result in death or serious personal injury.

⚠ WARNING:

An improperly functioning tool must not be used. Do not actuate the tool unless the tool is placed firmly against the work place.

WORK CONTACT ELEMENT (WCE)

1. Disconnect the air supply from the tool.
2. Remove all fasteners from the magazine.
3. Make sure the trigger and work contact element move freely up and down without sticking or binding.
4. Reconnect air supply to the tool.
5. Depress the work contact element against the work surface without pulling the trigger. The tool must not operate. Do not use the tool if it operates without pulling the trigger. Personal injury may result.
6. Remove the tool from the work surface. The work contact element (WCE) must return to its original down position. The tool must not operate. Do not use the tool if it operates while lifted from the work surface. Personal injury may result.
7. Pull the trigger and depress the work contact element (WCE) against the work surface. The tool must not operate.
8. Depress the work contact element (WCE) against the surface. Pull the trigger. The tool must operate.

CAUTION:

Check the operation of the work contact element trip mechanism before each use. The WCE must move freely without binding through its entire travel distance. The WCE spring must return the WCE to its fully extended position after being depressed. Do not operate the tool if the WCE trip mechanism is not operating properly. Personal injury may occur.

MAINTENANCE

⚠ WARNING:

Any time inspection, maintenance, and cleaning are done:

- ◆ Disconnect the tool from the air resource.
- ◆ Empty the magazine completely.

ANTI-DUST

Each tool is packed with an anti-dust cap on the air connector, check it after unpacking. Keep the anti-dust cap cover the air connector when the tool is not in use.

LUBRICATION

The tool is uniquely designed not to need daily lubrication. But lubrication is required for best performance after long periods of use. Oil for pneumatic fastening tools is added through the air line connection and will lubricate internal parts. Do not use detergent oil or additives. These lubricants will cause accelerated wear to the seals and bumpers in the tool, resulting in poor tool performance and frequent tool maintenance.

CAUTION:
Lubricate tool only with specified lubricants.

CLEARING

Avoid using solvents when cleaning plastic parts. Most plastics are susceptible to damage from various types of commercial solvents and maybe damaged by their use. Use clean cloths to remove dirt, dust, oil, grease, etc.

WARNING:
Do not at any time let brake fluids, gasoline, petroleum-based products, penetration oils, ect., come in contact with plastic parts. Chemicals can damage, weaken or destroy plastic which may result in serious personal injury.

COLD WEATHER OPERATION

For cold weather operation, near and below freezing, the moisture in the air line may freeze and prevent tool operation. We recommend the use of air tool lubricant or permanent antifreeze (ethylene glycol) as a cold weather lubricant.

CAUTION:
Do not store tools in a cold weather environment to prevent frost or ice formation on the tool's operating valves and mechanisms that could cause tool failure.

RECOMMENDED HOOKUP

1. The air compressor must be able to maintain a minimum of 60 psi when the tool is being used. An inadequate air supply can cause a loss of power and inconsistent driving.
2. An oiler can be used to provide oil circulation through the tool. A filter can be used to remove liquid and solid impurities which can rust or gum up internal parts of the tool.
3. Always use air supply hoses with a minimum working pressure rating equal to or greater than the pressure from the power source if a regulator fails, or 150 psi, whichever is greater. Use 3/8" air hose for runs up to 50'. Use 1/2" air hoses for 50' run or longer. For better performance, install a 3/8" quick plug (1/4" NPT thread) with an inside diameter of .315" (8mm) on the tool and 3/8" quick coupler on the air hose.
4. Use a pressure regulator on the compressor, with an operating pressure of 0-125 psi. A pressure regulator is required to control the operating pressure of the tool between 60 and

CAUTION:
The air compressor must be able to maintain a minimum of 60psi when the tool is being used. An inadequate air supply can cause a loss of power and inconsistent driving.

WARNING:
Do not connect with an air compressor which can potentially exceed 200psi. As tool may burst, possibly causing injury.

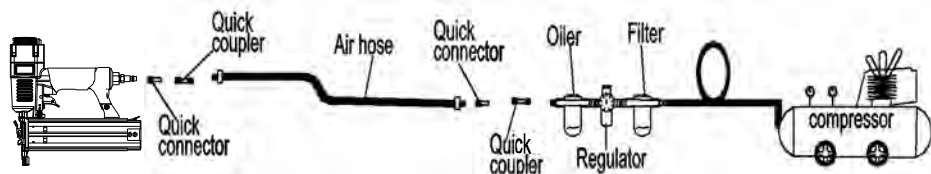

TROUBLE SHOOTING

WARNING:
Stop using tool immediately if any of the following problems occur. Serious personal injury could result. Any repairs or replacements must be done by a qualified service person or an authorized service center.

PROBLEMS	POSSIBLE CAUSE(S)	CORRECTIVE ACTION
Air leaking at trigger valve area.	O-rings in trigger valve housing are damaged	Replace o-rings. Check operation of Work Contact Element(WCE)
Air leaking between housing And nose.	Loose screws in housing 1.Damaged O-rings 2.Damaged bumper	Tighten screws 1.Replace o-rings 2.Replace bumper
Air leaking between housing and Cap.	1.Loose screws 2.Damaged gasket	1.Tighten screws 2.Replace gasket
Tool skips driving fastener	1.Worn bumper 2.Dirt in nose piece 3.Dirt or damage prevent fasteners or pusher from moving freely in magazine 4.Damaged pusher spring 5.Inadequate air flow to tool 6.Worn O-ring on piston or lack of lubrication 7.Damaged O-ring on trigger valve 8.Air leaks 9.Cap seal leaking	1.Replace bumper 2.Clean drive channel 3.Clean magazine 4.Replace spring 5.Check fitting, hose, or compressor 6.Replace and lubricate o-rings 7.Replace o-rings 8.Tighten screws and fittings 9.Replace gasket
Tool runs slow or has loss of power	1.Tool not lubricated sufficiently 2.Broken spring in cylinder cap 3.Exhaust port in cap is blocked	1.Lubricate nailer 2.Replace spring 3.Replace damaged internal parts
Fasteners are jammed in tool	1.Guide on driver is worn 2.Fasteners are not correct size 3.Fasteners are bent 4.Magazine or nose screws are loose 5.Driver is damaged	1.Replace guide 2.Use only recommended fasteners 3.Replace with undamaged fasteners 4.Tighten screws 5.Replace driver

WARNING:
Use only Freeman Authorized Repair Parts. For questions please call 1-888-669-5672 or visit our website at <http://www.freemantools.com>

WEARING PARTS

Repair parts can be ordered from our website: <http://www.freemantools.com>