



## 2.0 HP AIR COMPRESSOR



**MODEL: HP02W020S1**

# INSTRUCTION MANUAL

Wheels for rough terrain on job sites

## DANGER!

### Breathable Air Warning

This compressor/pump is NOT equipped and should NOT be used "as is" to supply breathing quality air. For any application of air for human consumption, you must fit the air compressor/pump with suitable in-line safety and alarm equipment. This additional equipment is necessary to properly filter and purify the air to meet minimal specifications for Grade D breathing as described in Compressed Gas Association Commodity Specification G 7.1 – 1966, OSHA 29 CFR 1910. 134, and/or Canadian Standards Associations (CSA).

### DISCLAIMER OF WARRANTIES

In the event the compressor is used for the purpose of breathing air application and proper in-line safety and alarm equipment is not simultaneously used, existing warranties are void, and Hulk air force technology & AIRBASE Industries, LLC disclaims any liability whatsoever for any loss, personal injury or damage.

### CALIFORNIA PROPOSITION 65



### WARNING!

This product or its power cord may contain chemicals known to the state of California to cause cancer and birth defects or other reproductive harm. Wash hands after handling.

#### ▪ **READ INSTRUCTION MANUAL BEFORE OPERATING**

- **RISK OF FIRE OR EXPLOSION**—DO NOT SPRAY COMBUSTIBLE/FLAMMABLE LIQUID IN A CONFINED AREA. SPRAY AREA MUST BE WELL VENTILATED. DO NOT SMOKE WHILE SPRAYING OR SPRAY WHERE SPARK OR FLAME IS PRESENT. ARCING PARTS – KEEP COMPRESSOR AT LEAST 20 FEET AWAY FROM SPRAYING AREA AND ALL EXPLOSIVE VAPORS.
- **RISK OF INJURY**– DO NOT DIRECT AIR STREAM AT BODY. USE EYE PROTECTION. COMPRESSOR STARTS AUTOMATICALLY. MOVING PARTS. DO NOT TOUCH. KEEP GUARDS IN PLACE. COMPRESSOR DOES NOT SUPPLY BREATHABLE AIR.
- **RISK OF BURSTING**– DO NOT ADJUST REGULATOR TO RESULT IN OUTPUT PRESSURE GREATER THAN MARKED MAXIMUM PRESSURE OF ATTACHMENT. IF A REGULATOR HAS NOT BEEN INSTALLED.

USE ONLY ATTACHMENT RATED AT 200 PSI OR HIGHER. DO NOT WELD ON OR REPAIR TANK – REPLACE. DO NOT OPERATE WITHOUT PROPER ASME SAFETY VALVE IN PLACE.

- **RISK OF ELECTRICAL SHOCK** – HAZARDOUS VOLTAGE: DISCONNECT FROM POWER SOURCE BEFORE SERVICING. COMPRESSOR MUST BE GROUNDED. DO NOT USE GROUNDING ADAPTORS. DO NOT EXPOSE TO RAIN. STORE INDOORS.

**IF CONNECTED TO A CIRCUIT PROTECTED BY FUSES, USE TIME-DELAY FUSE MARKED "D"**

**COMPLIES WITH CCR462 (L)(2).**

**DO NOT USE BELOW GARAGE FLOOR OR GRADE LEVEL**

**DRAIN TANK EVERYDAY TO PREVENT CORROSION AND POSSIBLE INJURY DUE TO TANK DAMAGE**

# IMPORTANT INFORMATION



**HULK**  
**LIMITED WARRANTY**  
**FOR THIS 2.0 HP AIR COMPRESSOR**

**3 Year limited warranty on pumps**  
**2 Year limited warranty on motors**

## **PROOF OF PURCHASE**

Please keep your dated proof of purchase for warranty and servicing purposes.

## **REPLACEMENT PARTS**

Replacement parts for this tool are available at our authorized HULK service centers across USA. For servicing, contact or return to the retailer where you purchased your product along with your proof of purchase. Please use the 10 digit part numbers listed in this manual for all part orders where applicable.

## **LIMITED TOOL WARRANTY**

HULK makes every effort to ensure that this product meets high quality and durability standards. HULK warrants to the original retail consumer a 2-year limited warranty as of the date the product was purchased at retail and that each product is free from defects in materials. Warranty does not apply to defects due directly or indirectly to misuse, abuse, negligence or accidents, repairs or alterations and lack of maintenance. HULK shall not be liable for death, injuries to persons or property or for incidental, special or consequential damages arising from the use of our products. To take advantage of this warranty, the manufacturer part must be returned for examination by the retailer. Shipping and handling charges may apply. If a defect is found, HULK will either repair or replace the product.



## **RISK OF EXPLOSION OR FIRE WHAT CAN HAPPEN**

It is normal for electrical contacts within the motor and pressure switch to spark.

If electrical sparks from the compressor come in contact with flammable vapors, they may ignite, causing fire or explosion. Restricting any of the compressor ventilation openings will cause serious overheating and could cause a fire.

Unattended operation of this compressor could result in personal injury or property damage.

## **HOW TO PREVENT**

Always operate the compressor in a well ventilated area free of combustible materials, gasoline or solvent vapors. If spraying flammable materials, locate the compressor at least 20 feet away from the spray area. An additional length of hose may be required.

Store flammable materials in a secure location away from the compressor.

Never place objects against or on top of the compressor. Operate compressor in an open area at least 12 inches away from any wall or obstruction that would restrict the flow of fresh air to the ventilation openings.

Operate compressor in a clean, dry and well ventilated area. Do not operate compressor indoors in a confined area.

Always remain in attendance with the compressor when it is operating.

## **HOW TO PREVENT**

Drain tank daily or after every use. If the tank develops a leak, replace tank or get a new air compressor. Never drill into, weld or make any modifications to the tank or its attachments.

The tank is designed to withstand specific operating pressures. Never make adjustments or parts substitutions to alter the factory set operating pressures.

For essential control of air pressure, you must install a pressure regulator and pressure gauge to the air outlet.

## **HOW TO PREVENT**

Never touch any exposed metal parts on compressor during or immediately after operation. The compressor will remain hot several minutes after use.

Do not reach around protective shrouds or attempt maintenance until the compressor has cooled down completely.

## **HOW TO PREVENT**

Always place compressor on a protective mat when transporting to protect against damage to vehicle from leaks. Remove compressor from vehicles immediately upon arrival.



## **RISK OF BURSTING WHAT CAN HAPPEN**

1. Failure to properly drain condensed water from the tank, causing rust and thinning of the steel tank.
2. Modifications or attempted repairs to the tank.
3. Unauthorized modifications to the unloader valve, safety valve or any other components which control tank pressure.
4. Excessive vibration can weaken the air tank and cause rupture or explosion.
5. Attachments & Accessories; Exceeding the operating pressure of air tools can cause them to explode.



## **RISK OF BURNS WHAT CAN HAPPEN**

Touching exposed metal such as the compressor head or outlet tubes, can result in serious burns.



## **RISK OF PROPERTY DAMAGE WHEN TRANSPORTING COMPRESSOR WHAT CAN HAPPEN**

Oil can leak or spill and could result in fire or breathing hazard, serious injury or death can result. Oil leaks will damage carpet, paint or other surfaces in vehicles or trailers.

## SPECIFICATIONS

Model .....	HP02W020S1
Voltage .....	120V
Horsepower .....	2.0 HP
Amperage .....	12.6A
Breaker size required.....	20A @ 120V
RPM (no load speed) .....	1150
Phase .....	1
Hertz .....	60Hz
Operating pressure .....	125 PSI
Tank size .....	20 Gallon

### WARNING

ALL ELECTRICAL INSTALLATIONS MUST BE PERFORMED BY A QUALIFIED ELECTRICIAN. FAILURE TO COMPLY MAY RESULT IN SERIOUS INJURY! ALL ADJUSTMENTS OR REPAIRS MUST BE PERFORMED WITH THE COMPRESSOR DISCONNECTED FROM THE POWER SOURCE. FAILURE TO COMPLY MAY RESULT IN SERIOUS INJURY!

## POWER SUPPLY

**WARNING:** YOUR COMPRESSOR MUST BE CONNECTED TO A 110V, WITH A MINIMUM 20 AMP. BRANCH CIRCUIT. FAILURE TO CONNECT IN THIS WAY CAN RESULT IN INJURY FROM SHOCK OR FIRE.

## GROUNDING

Your compressor must be properly grounded. Not all outlets are properly grounded. If you are not sure if your outlet is properly grounded, have it checked by a qualified electrician.

**WARNING:** IF NOT PROPERLY GROUNDED, THIS COMPRESSOR CAN CAUSE ELECTRICAL SHOCK, PARTICULARLY WHEN USED IN DAMP LOCATIONS. TO AVOID SHOCK OR FIRE, IF THE POWER CORD IS WORN OR DAMAGED IN ANY WAY, HAVE IT REPLACED IMMEDIATELY.

If this compressor should malfunction or breakdown, grounding provides a path of least resistance for electric current, to reduce the risk of electric shock. This compressor is equipped with a cord having an grounding conductor and grounding plug. The plug must be plugged into an appropriate outlet that is properly installed and grounded in accordance with all local codes and ordinances.

**WARNING:** TO MAINTAIN PROPER GROUNDING, DO NOT REMOVE OR ALTER THE GROUNDING PRONG IN ANY MANNER.

## 120V OPERATION

As received from the factory, your compressor is ready to run for 120V operation. This machine is intended for use on a circuit that has an outlet and a plug which looks like the one illustrated in Fig.1.

**WARNING:** DO NOT USE A TWO-PRONG ADAPTOR FOR THEY ARE NOT IN ACCORDANCE WITH LOCAL CODES AND ORDINANCES. NEVER USE IN USA.

## EXTENSION CORDS

The use of any extension cord will cause some loss of power. IT IS RECOMMENDED TO USE A LONGER AIR HOSE INSTEAD OF AN EXTENSION CORD. If you do not have a choice, use the table in Fig.2 to determine the minimum wire size (A.W.G-American Wire Gauge) extension cord. Use only 3-wire extension cords which have 3-prong grounding type plugs and 3-hole receptacles which accept the tool's plug.

For circuits that are further away from the electrical circuit box, the wire size must be increased proportionately in order to deliver ample voltage to the compressor motor. Refer to Fig.2 for wire length and size.

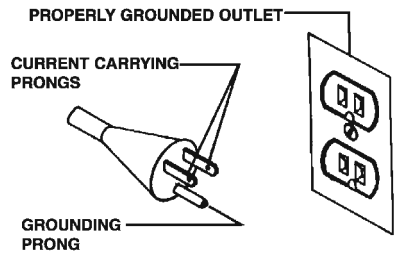

FIGURE 1

LENGTH OF CONDUCTOR	WIRE SIZES REQUIRED (AMERICAN WIRE GAUGE) 120V LINES
0-25 FEET	NO. 12
26-50 FEET	NO. 12
51-100 FEET	NO. 10

FIGURE 2

# OPERATION CONTROLS



**AIR COMPRESSOR PUMP.** To compress air, the piston moves up and down in the cylinder. On the downstroke, air is drawn in through the intake valves. The exhaust valves remain closed. On the upstroke of the piston, air is compressed. The intake valves close and compressed air is forced out through the exhaust valves.

**CHECK VALVE (A) FIG.3.** When the air compressor is operating, the check valve is "open", allowing compressed air to enter the air tank. When the air compressor reaches "Cut-Out" pressure, the check valve "closes", allowing air pressure to remain inside the air tank.

**ON/OFF SWITCH (A) FIG.5.** Turn this switch ON by lowering lever downwards to provide power to the automatic pressure switch and lift to turn compressor OFF.

**PRESSURE SWITCH (B) FIG.5.** The pressure switch automatically starts the motor when the tank pressure drops below the factory set "Cut-In" pressure. It also stops the motor when the air tank pressure reaches the factory set "Cut-Out" pressure.

**REGULATOR (F) FIG.5.** The air pressure coming from the air tank is controlled by the regulator. Turn the regulator knob clockwise to increase pressure and counterclockwise to decrease pressure. To avoid minor readjustment after making a change in the pressure setting, always approach the desired pressure from a lower pressure. When reducing from a higher to a lower setting, first reduce the pressure less than that desired, then bring it up to the desired pressure. Depending on the air requirements of each particular accessory, the outlet regulated air pressure may have to be adjusted while operating the accessory.

**OUTLET PRESSURE GAUGE (E) FIG.5.** The outlet pressure gauge indicates the air pressure available at the outlet side of the regulator. The pressure is controlled by the regulator and is always less than or equal to the tank pressure.

**TANK PRESSURE GAUGE (D) FIG. 5.** The tank pressure gauge indicates the reserve air pressure in the tank.

**COOLING SYSTEM.** This compressor contains an advanced design cooling system. The cooling system works when air is being expelled.

**DRAIN VALVE (A) FIG. 4.** The drain valve is located at the base of the air tank and is used to drain condensation from the tank to prevent corrosion. Drain tank after each use.

**MOTOR THERMAL OVERLOAD PROTECTOR (RESET (A) FIG. 6).** The electric motor has an automatic thermal overload protector. If the motor overheats for any reason, the thermal overload protector will shut off the motor. The motor must be allowed to cool before restarting. Press the reset button (A).

**PRESSURE RELEASE VALVE.** The pressure release valve located on the side of the pressure switch, is designed to automatically release compressed air from the compressor head and the outlet tube when the air compressor reaches "Cut-Out" pressure or is shut off. The pressure release valve allows the motor to restart freely. When the motor stops running, air will be heard escaping from this valve for a few seconds. No air should be heard leaking when the motor is running, or continuous leaking after unit reaches "Cut-Out" pressure.

**SAFETY VALVE (C) FIG. 5.** If the pressure switch does not shut off the air compressor at its "Cut-Out" pressure setting, the safety valve will protect against high pressure by "popping out" at its factory set pressure (slightly higher than the pressure switch "Cut-Out" setting).

**WARNING:** If the safety valve does not work properly, over pressurization may occur, causing air tank rupture or an explosion. Pull the ring daily on the safety valve to make sure that the safety valve operates freely. If the valve is stuck or does not operate smoothly, it must be replaced with the same type of valve before operating again.

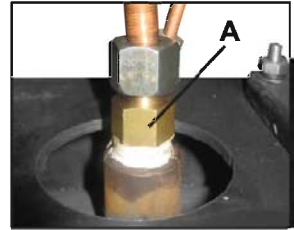

FIGURE 3

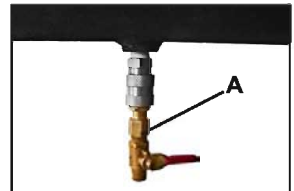

FIGURE 4

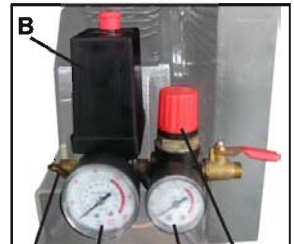

FIGURE 5



FIGURE 6

## LOCATION OF THE AIR COMPRESSOR

Your compressor comes almost completely assembled. Only the air filter needs to be installed. Operate the air compressor in a dry, clean, cool, well ventilated area. The air compressor pump and case are designed to allow for proper cooling. Clean or blow off dust or dirt that collects on the air compressor. A clean air compressor runs cooler and provides longer service. The ventilation openings on your air compressor are necessary to maintain proper operating temperature. Do not place rags or other containers on or near these openings.

## ADDITIONAL REGULATORS AND CONTROLS

Since the air tank pressure is usually greater than that which is needed, a regulator is employed to control the air pressure ahead of any individual driven device. Separate air transformers which combine the function of air regulation, moisture and dirt removal should be used where applicable.

## BREAK-IN PROCEDURES

**NOTE: SERIOUS DAMAGE MAY RESULT IF THE FOLLOWING BREAK-IN INSTRUCTIONS ARE NOT CLOSELY FOLLOWED. THIS PROCEDURE IS REQUIRED BEFORE THE AIR COMPRESSOR CAN BE PUT INTO SERVICE, AFTER REPLACING THE CHECK VALVE, AND WHEN THE PISTON OR THE CYLINDER SLEEVE IS REPLACED.**

- A. Fill crankcase with oil as described in "Changing Oil" in the maintenance section on the following page.
- B. Set the pressure switch lever to the "OFF" position.
- C. Plug the power cord into the correct 120V branch circuit receptacle.
- D. Fully open the drain valve (A) Fig. 4, by turning it counterclockwise, to prevent air pressure build-up in the tank.
- E. Move the pressure switch lever to "ON". The compressor will start.
- F. Run the compressor for 15 minutes. Make sure the drain valve is open and there is no tank pressure build-up by watching the tank pressure gauge.
- G. After 15 minutes, close the drain valve by turning clockwise. The air receiver will fill to "Cut-Out" pressure and the motor will stop. The compressor is now ready for use.

## OPERATING PROCEDURES

Preparation for use:

1. Before attaching an air hose or accessories, make sure the OFF lever is set to "OFF" and the air regulator is closed. Once this is done, you can now attach a hose or an accessory.

**WARNING:** Too much air pressure causes a hazardous risk of bursting. Check the manufacturer's maximum pressure rating for air tools and accessories. The regulator outlet pressure must never exceed the maximum pressure rating of the tool being used.

3. Turn the "ON/OFF" lever to "ON" and allow tank pressure to build. Motor will stop when tank pressure reaches "Cut-Out" pressure.
4. Open the regulator by turning it clockwise. Adjust the regulator to the correct pressure setting. The compressor is ready for use.
5. Always operate the air compressor in well ventilated areas; free of gasoline or other solvent vapors. Do not operate the compressor near the spray area.

After Use:

6. Set the "ON/OFF" lever to "OFF".
7. Turn the regulator counterclockwise to set the outlet pressure to zero.
8. Disconnect the air tool or accessory.
9. Pull ring on safety valve (C) Fig. 5, allowing air to bleed from the tank until tank pressure is approximately 20 psi. Release safety valve ring.
10. Drain water from air tank. Turn drain valve (A) Fig. 4, counterclockwise to open.

**WARNING: WATER WILL CONDENSE IN THE AIR TANK. IF NOT DRAINED REGULARLY, WATER WILL CORRODE AND WEAKEN THE AIR TANK CAUSING A RISK OF AIR TANK RUPTURE.**

**NOTE:** If drain valve is plugged, pull ring on safety valve (C) Fig. 5, and hold until air pressure has been released. The valve can then be removed, cleaned, and reinstalled.

11. After the water has been completely drained, turn drain valve to close. The air compressor can now be stored.

## MAINTENANCE

Before doing any maintenance or adjustments to your air compressor, the following safety precautions should be taken:

- Disconnect electrical power.
- Drain air tank of pressure.

### Daily or before each use

1. Check oil level. The oil level should be centered with the red dot which appears in the oil sight glass (B) Fig.8.
2. Drain condensation from tank.
3. Check for any unusual noise or vibration.
4. Be sure all nuts and bolts are tight.

### Monthly

1. Inspect air system for leaks by applying soapy water to all joints. Tighten those joints if leakage is observed.

### 250 hours or six months (whichever comes first)

1. Change compressor oil. See following instructions.
2. Replace oil more often if compressor is used near paint spraying operations or in dusty environments.

## CHANGING OIL

To change oil, oil must be drained from the crank case by unscrewing and removing oil sight glass (B) Fig.8. Drain oil and replace oil sight glass. To fill the crank case with oil, first unscrew and remove oil breather cap (A), pour air compressor oil (SAE 10W30 or SAE 10W20 weight non-detergent compressor oil) into crank case oil opening until the oil level reaches the red dot at the center mark of the oil sight glass. Secure oil breather cap (A).

## KEEP TOOL CLEAN

Periodically blow out all air passages with dry compressed air. Clean all plastic parts with a soft damp cloth. NEVER use solvents to clean plastic parts. They could possibly dissolve or otherwise damage the material.

**CAUTION:** Wear safety glasses while using compressed air.

## FAILURE TO START

Should your compressor fail to start, check to make sure the prongs on

the cord plug are making good contact in the outlet. Also, check for blown fuses or open circuit breakers in the line.

## STORAGE

1. Set the "ON/OFF" lever to "OFF".
2. Turn the regulator counterclockwise to set the outlet pressure to zero.
3. Remove the air tool or accessory .
4. Pull ring on safety valve (C) Fig. 5, allowing air to bleed from the tank, until tank pressure is approximately 20psi. Release safety valve ring.
5. Drain water from air tank. Turn drain valve (A) Fig. 4, counterclockwise, to open.

**NOTE:** If drain valve is plugged, pull ring on safety valve (C) Fig. 5, and hold until air pressure has been released. The valve can then be removed, cleaned, and reinstalled.

6. After the water has been completely drained, turn drain valve to close. The air compressor can now be stored.
7. Store the air compressor in a clean and dry location.

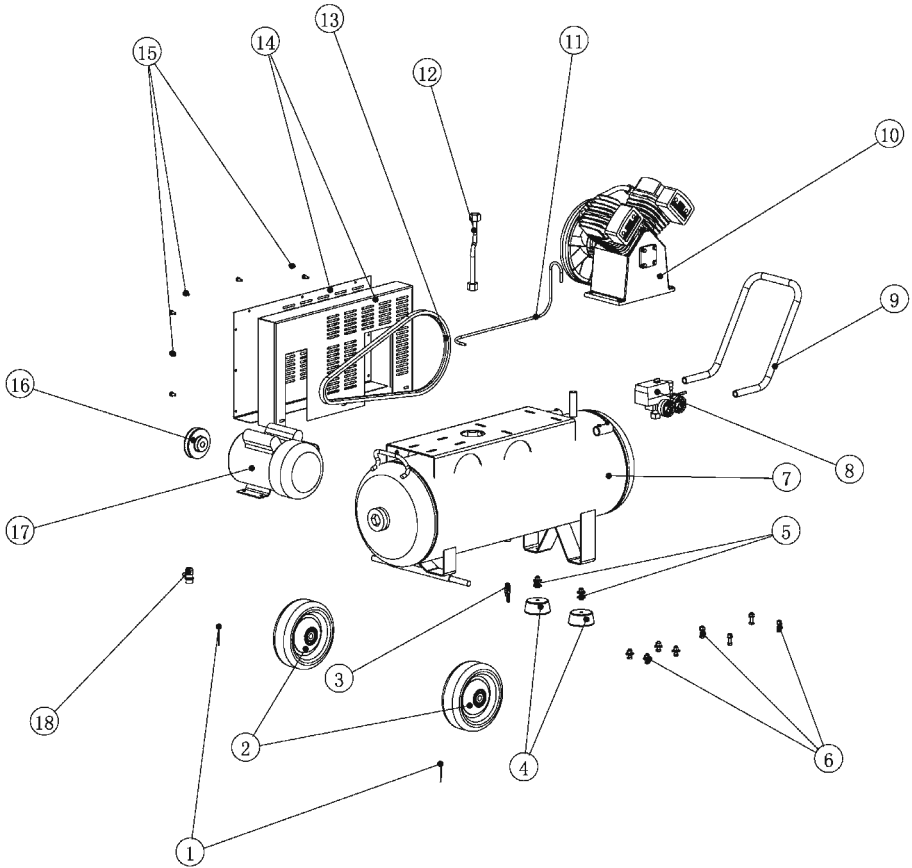

**FIGURE 8**

## TROUBLE SHOOTING

TROUBLE	POSSIBLE CAUSE	CORRECTIVE ACTION
No start condition	Fuse blown or circuit breaker tripped Loose electrical connections Overheated motor	Check voltage or eliminate extension cord or reset Check wiring connections Press the reset button or wait for automatic reset
Low pressure	Air leak in safety valve Restricted air filter Defective check valve	Check valve manually by pulling upwards on ring. If condition persists replace valve Clean or replace as necessary Replace check valve
Safety valve releasing	Defective pressure switch or improper adjustment	Check for proper adjustment and if problem persists, replace pressure switch
Oil discharge in air	Improper oil viscosity Too much oil in crankcase Compressor overheated Restricted air filter	Replace oil with SAE 10W30 or SAE 10W20 non-detergent compressor oil. Drain crankcase and fill to proper level Air pressure regulated too high Replace filter







No.	Part Number	Description	Qty
1	HP30803005	HATCH PIN	2
2	WH51003015	WHEEL	2
3	DV50404102	DRAIN VALVE	1
4	RF51001000	RUBBER FEET	2
5	BO30208031	BOLT	2
6	BO30208041	BOLT	8
7	TA21005000	TANK	1
8	SA73340107	HORIZONTAL SWITCH ASSEMBLY	1
9	HA20901004	HANDLE	1
10	PU70500000	PUMP	1
11	UP50835011	UNLOADER PIPE	1
12	EP50834023	EXHAUST PIPE	1
13	BE51200010	BELT	1
14	SG50119200	SAFETY GUARD	1
15	BO30316021	BOLT	9
16	MW01021218	MOTOR WHEEL	1
17	MO10208017	MOTOR	1
18	CV50405005	CHECK VALVE	1



1000 Cass Drive Clayton, Ohio 45315

Toll Free: 866-294-4153

Fax: 937-540-1150

[sales@emaxcompressor.com](mailto:sales@emaxcompressor.com)