

<p style="text-align: right;">EN</p> <p>IAD Series Refrigeration Air Dryer Air Cooled Direct Expansion Dryers</p> <p>IAD15 to IAD45 Model Maintenance and User Guide</p>	<p style="text-align: right;">ES</p> <p>IAD Series Secador de Aire Refrigerativo Secador de Expansión Directa Enfriado por Aire</p> <p>del IAD15 al IAD85 Manual de Mantenimiento y Operación</p>	<p style="text-align: right;">FR</p> <p>IAD Series Secheur D'air par Refrigeration Sécheurs D'air à Détente Directe en Refroidissement par Air</p> <p>Modèles IAD15 à IAD45 Manuel D'utilisation et de Maintenance</p>
---	--	---

***WARNING:**

This product contains chemicals known to the State of California to cause cancer, birth defects and/or reproductive harm.

***ALERTA:**

Este producto contiene sustancias químicas que, según el estado de California, producen cáncer, defectos de nacimiento u otros daños reproductivos.

***ATTENTION :**

Ce produit contient des substances chimiques connues par l'Etat de Californie pouvant provoquer des cancers, et/ou des malformations de naissance.

GENERAL

This manual is meant for anyone who uses or works on the Refrigeration Air Dryer, mainly the operators.

The refrigeration air dryer and this manual are protected by copyright. Any reproduction of the same shall be liable for prosecution.

All rights reserved by MAT Industries, LLC., particularly the rights of reproduction and distribution, as well as translation, including those relating to charges of copyright infringement. Any reproduction, processing, duplication, distribution of this document using electronic or mechanical means without the prior written authorization of MAT Industries, LLC. is strictly prohibited. This document may have errors and is likely to be modified with respect to technical features.

MACHINE CODE IDENTIFICATION

The model of the machine, write on the **rating plate**, it's very easy to recognize it by the name (see example).

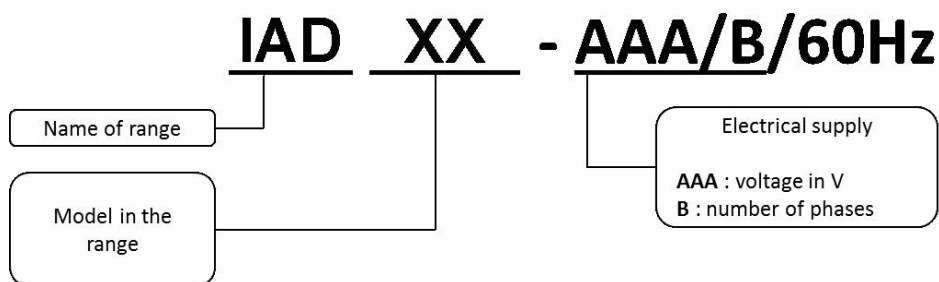

CONTENTS

GENERAL	2
MACHINE CODE IDENTIFICATION	2
CONTENTS	3
WARRANTY	4
GENERAL WARNINGS	4
BASIC SAFETY RULES	4
QUALIFIED OPERATORS	5
SAFETY	6
STORAGE	7
TRANSPORT AND HANDLING	7
COMPRESSED AIR INSTALLATION PRINCIPLE	8
OPERATING PRINCIPLE OF THE DRYER	9
INSTALLATION	11
OPERATION	13
USE	13
CONTROLLER INSTRUCTIONS	14
SAFETY SYSTEM	16
ROUTINE MAINTENANCE	16
TROUBLESHOOTING IN THE EVENT OF MALFUNCTION	18
CORRECTIVE MAINTENANCE	19
ARRANGEMENT DRAWINGS	20
ELECTRICAL WIRINGS	21
APPENDIXES	22
CHEMICAL SAFETY DATA SHEETS	23

WARRANTY

The unit described in this manual **is covered by the warranty below**, which is considered automatically accepted and signed by the customer on the date that the order was placed with **MAT Industries, LLC**.

The supplier guarantees good performance and quality of the supplied equipment and undertakes, during the warranty period specified below, to repair or replace, depending on his/her assessment and at the earliest possible, the parts which prove to be defective after examination, owing to a material or manufacturing defect rendering them unsuitable for the intended purpose of use. The above shall not be applicable in the case of negligence of the buyer, damage caused by normal wear and tear, negligence of or improper use by the user, damage caused by third-parties, instances of force majeure or in any case where damage is caused by factors that cannot be attributed to the defects in product quality.

The supplier shall in no way be liable to pay for the direct or indirect damage, irrespective of its nature, or due to any reason.

The warranty will be automatically cancelled if the units, for which the claim is made, have been repaired or modified in any manner.

The warranty and its aforementioned terms are subject to the buyer's obligation to settle the payment for the equipment and honor the contractual terms.

No employee or representative of the sales department or the After-Sales Service Center of **MAT Industries, LLC** or any other person is authorized to grant an exemption from the warranty and the aforementioned terms.

GENERAL WARNINGS

 Read the contents of this manual carefully before starting the units.

 This service and maintenance manual describes the design, operation and the instructions for use and maintenance of the units supplied by **MAT Industries, LLC**.

 **MAT Industries, LLC** shall not be liable for any damage caused due to non-compliance with the instructions of this manual.

 For the smallest doubts or any clarifications that may be required, our qualified **MAT Industries, LLC** technicians are available to provide all the necessary information.

 In order to make it easier to identify the units, it is important to always specify the technical features, especially the serial number, which are printed on the label on the outside of the units.

 The unit should not be operated, even for a short period of time, under conditions other than the ideal conditions.

 A part that does not guarantee safety should not be assembled.

BASIC SAFETY RULES

 The installer must provide an emergency stop button on the unit. He/she should ensure that this is done before the unit is started.

 The unit is equipped with protective covers for the components. The unit is designed for indoor use only.

 Replace all the supply lines of the different power sources which are damaged or missing.

 The refrigerant used is R134a. It is not harmful unless inhaled. It can constitute a hazard only if it saturates the environment. Some fluids are flammable under certain conditions. Refer to the specifications of R134a on the **safety data sheet at the end of the manual**.

 The compressor lubricant is not hazardous. However, it is always compulsory to wear safety gloves while working with it. Do not swallow the lubricant.





 For any operations relating to the installation, commissioning, fitting, use, modifications of the conditions of use and methods, routine maintenance, inspection and scheduled maintenance, follow the procedures given in the corresponding chapters of this manual. Keep this manual at hand for quick reference.





 The unit must be used under the conditions specified in this service and maintenance manual.

There are some recommendations given below for the **USER** that should help to avoid abnormal operating conditions. Avoid any operating conditions other than those expressly described in this manual.

 Do not climb on the unit;

 Operate the unit after it is properly installed in the recommended position;

-  Operate the unit after it is properly installed in the recommended position;
-  Do not start the unit without the protecting covers properly in place;
-  Do not remove the protecting elements while the unit is functioning;
-  Do not remove the protecting elements when the unit is switched on;

-  Do not clean the unit when it is in operation;
-  Do not install the unit in corrosive or explosive places;
-  Do not disconnect or remove the safety devices and parts;
-  It is prohibited to operate the unit under conditions other than those specified in this manual.

MAT Industries, LLC shall not be held responsible for any possible damage caused, directly or indirectly, by persons or elements following non-compliance with these instructions.

Any assembling/removal carried out by THE USER, which is not provided for in this manual or not authorised by "MAT Industries, LLC", will be considered as an inappropriate operation, thereby damaging safety functions, and will lead to the cancellation of the warranty.

QUALIFIED OPERATORS

Only the professionals stated below are authorized to operate the unit after having received all the necessary instructions from this manual:

Specialized maintenance electrician
 The electrician should have a general knowledge about electrical appliances as well as specific experience working with control boxes and the electrical components of cooling units or similar equipment from the domain of air-conditioning.
 The electrician is authorized to carry out only the specific operations stated in this manual by meticulously following the associated instructions.

Maintenance technician
 The maintenance technician should have a general experience working with mechanical elements and a specific experience with cooling units or similar equipment from the domain of air-conditioning.
 The maintenance technician is authorized to carry out only the specific operations stated in this manual by meticulously following the associated instructions.

Refrigeration technician
 The refrigeration technician should be a refrigeration certified from a technical institution for similar equipment or interventions under the authority of competent personnel.
 The refrigeration technician is authorized to carry out only the specific operations stated in this manual by meticulously following the associated instructions.

Transport operator
 The transport operator can carry out only the specific operations stated in this manual by meticulously following the associated instructions.

Staff allocated for the start-up and shut-down of the unit
 (Basic operator and engineer operator)
 After having understood the information contained in this manual, the basic operator will be authorized to manually operate the unit at the level of the following functions: start-up, shut-down, display of alarms.
 In this case, this operator can carry out only the specific operations stated in this manual by meticulously following the associated instructions.

Safety officer
 The safety officer is responsible for protection and the prevention of occupational risks as set forth in **OSHA Directive** (Safety in the workplace).
 The safety officer shall make certain that all the persons who operate the unit have received all applicable instructions which are contained in this manual, including the initial installation and commissioning operations.

Essential safety rules

⚠ WARNING

Read this paragraph carefully and understand it before operating or servicing this machine. The machine is connected to hazardous power circuits (electricity, pneumatic circuit, etc.) and should be used with great care.

This paragraph explains what needs to be understood in terms of safety before operating or servicing the machine. Non-compliance with these safety instructions risks causing injuries or fatal accidents, break-down of the machine, products (plates) or installations, or a serious incident.

Operator

- Prior training about the operation and maintenance of the device is a prerequisite for the use and maintenance of the dryer.
- Use and maintain the dryer with the consent of the system manager.
- It is very dangerous to let a person, with poor knowledge and poor understanding about the system and how the machine functions, use it and carry out maintenance operations in an improper or negligent manner.

Before operating the dryer:

- Anyone using the dryer or carrying out its maintenance operations must read this manual carefully and understand its contents. Pay special attention to explanations with the heading "Danger", "Warning" and "Caution" and understand them thoroughly. Follow the instructions and avoid predictable hazards when you use the dryer or carry out its maintenance operations.
- Before operating or carrying out a maintenance operation, read and understand the safety instructions stated in this manual and the safety labels stuck on the device, and follow the instructions. Failing the above, you risk suffering facial injuries or even fatal injuries. You also run the risk of the dryer, the products (plates) or the installation breaking down or causing a serious incident.
- Other safety instructions are provided in the other paragraphs.

Warning labels (Warning)

- Warning labels are very important. Do not remove them deliberately.

- If they become dirty or illegible, or they get removed inadvertently or are lost, stick new labels in the place of the earlier ones.

Danger warning

When you use the dryer, or carry out a maintenance operation on it, pay attention to the three warning levels below. Understand their content and act accordingly. The warning messages appear on the warning labels stuck on the dryer and given in the Safety instructions paragraph of this manual.

⚠ DANGER

The "danger" messages provide warning about real dangers and indicate the risks of fatal accident or serious injuries for the operator who does not strictly adhere to the safety instructions provided to avoid such dangers. They also provide warning about the risks of an accidental gas leakage or fire due to improper handling.

The content of the messages is identical to the warning messages, except for indicating a higher level of severity. Danger labels generally have a red background.

⚠ WARNING

The "warning" messages provide warning about real dangers and indicate the risks of serious injuries or fatal accident for the operator who does not strictly adhere to the safety instructions provided to avoid such dangers. They also provide warning about the risks of an accidental gas leakage or fire due to improper handling. Warning labels generally have an orange background.

⚠ CAUTION

The "caution" messages provide warning about real dangers and indicate the risks of minor injuries for the operator, or damage to the system, products (plates) and installations, if he/she does not strictly adhere to the safety instructions provided to avoid such dangers. Caution labels generally have a yellow background.

STORAGE

Keep away from:

- **Direct sunshine, rain, wind and sand.**
- **Temperature: max. 140°F/min. 14°F**
- **Max. relative humidity: 90%**

TRANSPORT and HANDLING



The carrier is always liable for any damage caused to the products entrusted to them during transport. Thus, before preparing the unit for its installation and commissioning, it is necessary to carry out a complete visual inspection in order to check that the packing cases are intact and the unit has no apparent damage and that there is no oil or refrigerant leakage. It is also important to verify that the units are the ones that have been ordered.



Any damage or complaints must be reported to **MAT Industries, LLC** and declared to the carrier by registered letter within eight days of receiving the equipment.



If there is damage to one or more components, do not start the unit but inform **MAT Industries, LLC** about the problem to find a mutually agreeable course of action.



Preferably, remove the packaging at the actual place of installation.

The unit should be handled with great care on the premises. Do not use any of its components as a grip. In order to avoid any damage, it is imperative that, during their handling, the units always remain in the position set for their operation.



Do not leave the units in their packaging on premises that are exposed to strong sunshine because the ambient temperatures can affect the triggering values of the safety devices.



The water circuit should be completely drained before the unit is handled.



The equipment should be preferably lifted using a forklift truck. Use a spreader bar if belts or slings are used and ensure that there is no pressure on the external edges of the units or the packing case.

During transport, do not place the dryer on the ground, on the side, in order to avoid any possible problem.

Example of lifting using a forklift truck:

- Insert the protection for the external structure of the unit, e.g. polystyrene or board sheet (A).
- Ensure that the forks of the truck jut out min. 4 inches (B) from the unit.

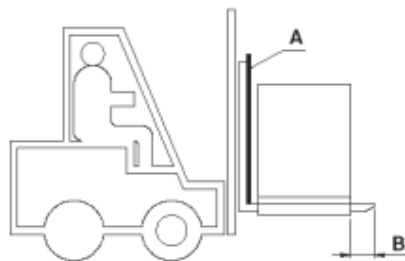

Example of lifting using slings:

- Place the slings as shown.
- Place the rigid structures on the upper sides of the unit in order to avoid damaging it (only when there is a point on which the pressure acts).
- Tighten the slings gradually, while ensuring that they remain in the correct position.
- Start lifting the unit.

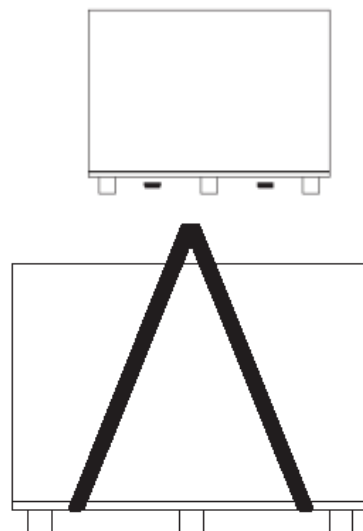

COMPRESSED AIR INSTALLATION PRINCIPLE



For air dryer inlet and outlet connections tightening, be sure not to use too much torque which would damage the evaporator coil piping of the thermal mass.

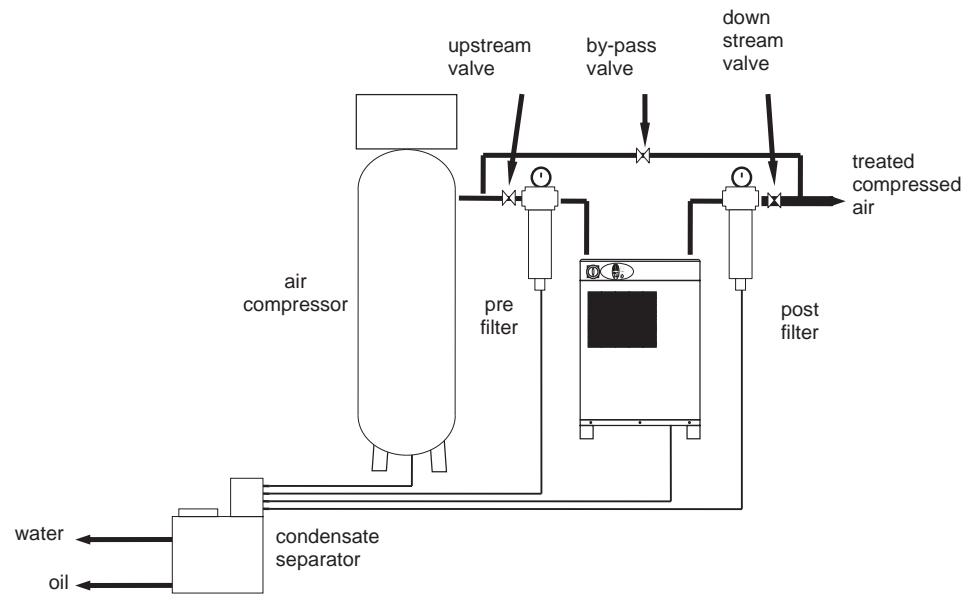

OPERATING PRINCIPLE OF THE DRYER

Schematic diagram

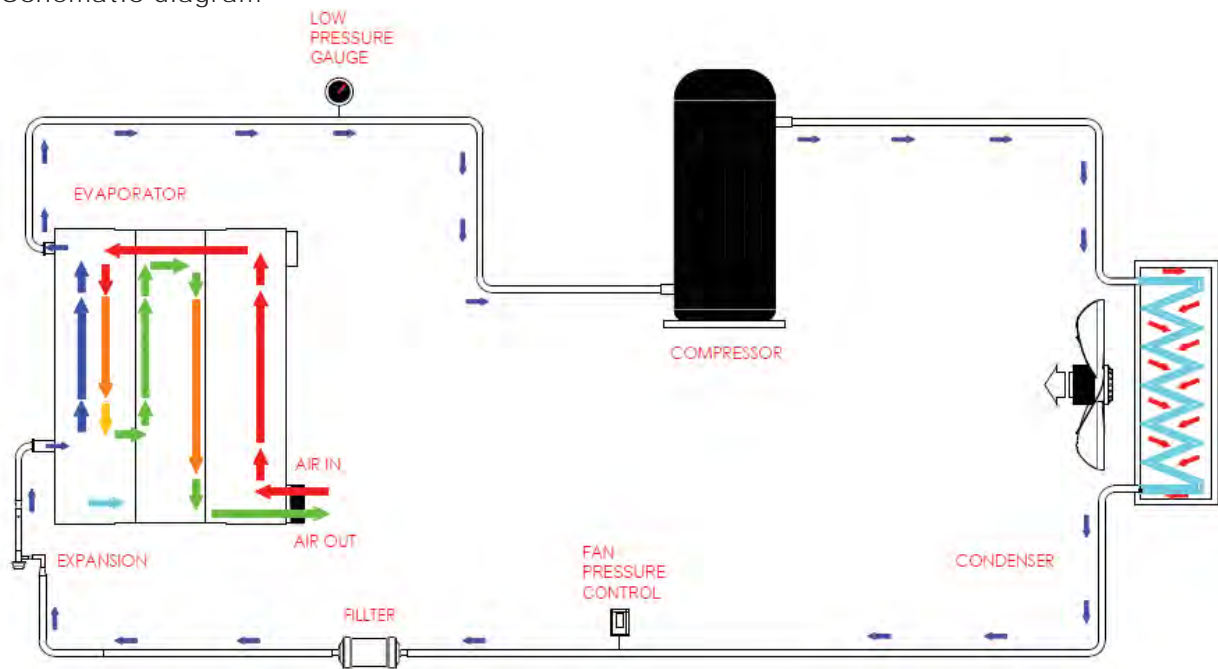

Models: IAD15 - 45

Operating principle

1. Compressed air, with high temperature and humidity (relative 100%), from the compressor penetrates the dryer through an air circuit/freon circuit plate heat exchanger. It is pre-cooled by the outgoing air, which is treated and colder. Then it goes in the second section of the exchanger (air/freon) to be cooled.
2. The air cools down to attain a dew point temperature under pressure of 50°F rated flow. This cooling is controlled by the refrigerating circuit. During this phase, the saturated steam transforms into condensed water which is then evacuated through the drain device integrated in the plate heat exchanger (automatic purge).
3. If the flow is high, a hot gas valve regulates the temperature in the evaporator by an adjustment of the refrigeration gas volume and constant dew point control. This avoids excessive cooling and maintains the cooling temperature of the compressed air at a constant level.

INSTALLATION

Note: These instructions help to improve the service durability of the equipment. Please read them carefully and follow them.

Location of the Dryer

- 1) Place the dryer on a surface in a horizontal position.

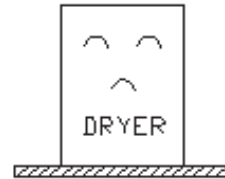

- 2) The dryer can corrode quickly if it is placed on a surface that is contaminated by acid or alkali.

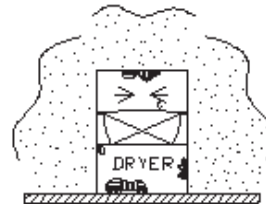

- 3) The place of installation should be clear and have sufficient space. (Blocked air circulation reduces the rate of dehumidification and the service life of the dryer).
Provide for a 4.9 feet clear space around the dryer to facilitate maintenance operations and repairs.

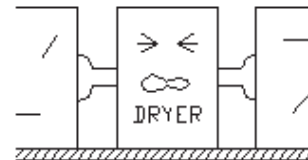

- 4) The place of installation should be perfectly clean and free of vibrations.

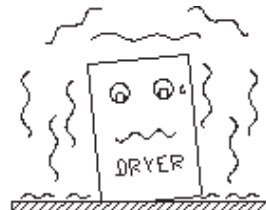

- 5) The ambient temperature of the place of installation should be greater than 32°F to avoid the dryer freezing up in winter. The place of installation should not have direct exposure to sun rays.

(Ambient temperature: 32-110°F).

※ It is necessary to arrange for suitable ventilation in order to prevent any malfunctioning.

※ In case the temperature in winter is colder than 32°F, contact the office to obtain specific dryers configuration.



- 6) There should be no flammable products at the place of installation.



Piping

The pipework should be installed using standard tools and connected in such a way that there is no AIR leaking from the connections. Any malfunction and leakage in the system can also be avoided with an installation that is properly adjusted taking into account the possible movements and loosening of the connections for varied reasons.

- 1) The pipes should be assembled in accordance with the direction of circulation of the compressed air after inspection of the inlet and outlet of the AIR DRYER. (Assembling the pipes in the wrong direction causes the AIR DRYER to malfunction).

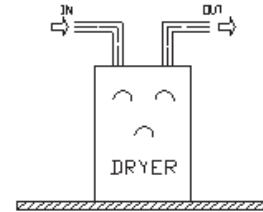

- 2) The pipes should not rest directly on the AIR DRYER but on a support so that they are isolated from the device.

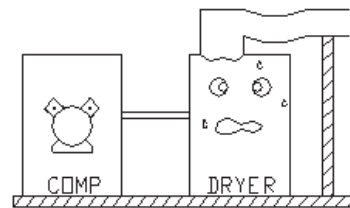

- 3) Condensed water coming in from the outlet of the drain device should be evacuated through a separate pipe.

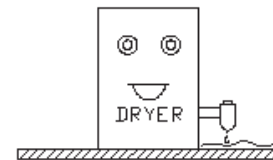

- 4) The AIR DRYER should be isolated from the vibrations of the AIR COMPRESSOR.

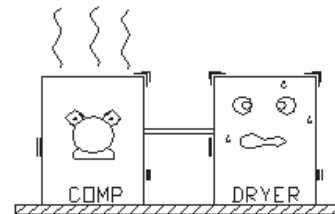

- 5) It is recommended to install a bypass line in order to facilitate repairing the AIR DRYER (use connecting pipes).

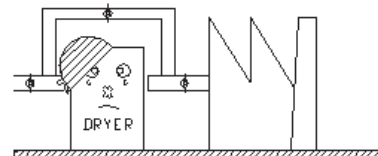

- 6) It is also recommended to use non-corrosive piping for better corrosion resistance.

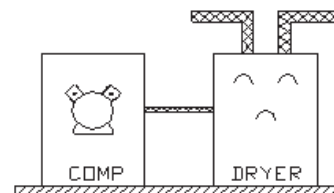

Electrical connection

- 1) Connection: Use conductors which can carry the maximum current required at the maximum ambient operating temperature, according the type of installation chosen (see indication on the electrical diagram). Use only UL/CSA marked copper cables in conformity with NEC (National Electrical Code) and CEC (Canadian Electrical Code).
- 2) Appropriate protection should be installed to avoid over current and possible electrocution due to short-circuit before installing the air dryer.
- 3) Proper grounding should be installed.
- 4) Permissible operating voltage range: $\pm 5\%$
- 5) Refer to the electrical schematic and direct any questions to **MAT Industries, LLC** technical support.

OPERATION

Functional test

Start the air dryer after the following checks are made:

Inspection of the components:

- 1) Is there a problem in the air system and electric circuit?
- 2) Has the by-pass circuit valve (in option) been closed?
- 3) Is the purge system valve open?
- 4) Is the compressed air pressure sufficient?
- 5) Is there a differential between the permissible rated voltage and the interrupting capacity of the fuses and the circuit-breaker?

Operating procedure

Press the "ON" power button (press the button of the controller in the front and hold for a while for CAREL controllers)

We recommend to start the dryer, prior to opening up the air inlet and outlet valves for five minutes. After starting the unit and running it for five minutes slowly pressurize the dryer to avoid any possible damage. The condensate drain should be cycled to ensure functionality and then slowly open the outlet valve to the system.

(If compressed air enters the dryer quickly, the pressure could damage parts or instruments).

• Important! •

Wait for more than 5 minutes before restarting the dryer.

USE

Initial start-up of IAD refrigerated air dryer



Only start up the dryer once you have thoroughly tested all the compressed air, refrigeration and electrical connections.

1. Close the isolating valves on the dryer and open the by-pass valve.
2. Check on the controller that the dryer is OFF.
3. Start the air compressor
4. Start the dryer. (press on the arrow up button, the controller will display ON)
5. The refrigerating compressor and condenser fan will start after a 2-minute safety time-out interval.
6. Pressurize the dryer by slowly opening the inlet valve.
7. Slowly open the dryer outlet valve and then close the by-pass.
8. Check that the condensate drain opens when you push the arrow's down button.
9. Check that the condensate drain valve opens automatically every 5 minutes.

The dryer is now ready to run normally.

CONTROLLER INSTRUCTIONS

User interface - with CAREL



Modifying the other parameters

Parameters access

- Press and hold SET button for 3 seconds until you reach P5.
- Press the UP and DOWN arrows to scroll the list of available parameters
- Press the SET button to show the relevant parameters value
- Increase or decrease the parameters value by using the UP and DOWN arrows keys
- Press the set button to memorize the parameters value and return to the parameters display
- Follow the same procedure above to review all of the relevant parameters
- Press and hold the set button for 3 seconds to memorize and lock in the parameters. The display will exit the parameter setting menu. Note that if this last operation of holding the set button for 3 seconds is not completed all changes to parameters will revert to previous values and modifications to parameters will not be applied.

Parameters Table

Parameters	Description	Min	Max	Default	Unit
/4	Select probe display ¹	1	3	1	
/C1	Offset of probe 1 ²	10.4	53.6	28.4	°F
/C2	Offset of probe 2 (not used)	10.4	53.6	28.4	°F
/C3	Offset of probe 3 (not used)	10.4	53.6	28.4	°F
Set	Set point	30	176	30	°F
Rd	Control differential (not used)	32	176	32	°F
P1	Duration of auto purge	0	999	4	Second
P2	Time interval between two auto purges	0	999	2	Minute
P3	Short manual purge cycle	0	999	1	Minute
P4	Long manual purge cycle	0	999	0	Minute
AL (not used)	Threshold/Deviation for the low temperature alarm	-58	302	32	°F
AH (not used)	Threshold/Deviation for the high temperature alarm	-58	302	32	°F

Changing condensate drains parameters

General

- The condensate drain energizes automatically opens every two minutes (parameter p2) for a duration of four seconds (parameter p1). The factory setting matches the standard operating conditions of the dryer. However, you may have to :
 - increase the duration and possibly the frequency of purging if the temperature of the air to be treated is higher than the rated value and if there is water in liquid condensate downstream of the dryer.
 - decrease the duration and possibly the frequency of the condensate drain if the temperature of the air to be treated is lesser than the rated value (in the case of a water aftercooler after the air compressor) or if the compressed air to be treated is not saturated with humidity (pre-drying or partial expansion)

The objective of properly adjusting the purge duration is simply to limit the loss compressed air to the absolute minimum required for this operation. A properly adjusted purging operation is characterized by:

- the expulsion of condensates (water/oil emulsion) for the majority of the purge time.
- a short jet of dry compressed air without condensates at the end of the purge

Functioning of manual purge

Short cycle:

- Press the purge icon and hold for 1 second.
- The screen displays “Sho” for the first three seconds
- Release the button to start the short purge cycle (refer to P3 parameter)

Long cycle:

- Press the purge icon and hold for several seconds.
- The screen displays “Sho” for the first three seconds and then displays “Lon”.
- When the screen displays “Lon”, release the button to start the long purge cycle. (refer to P4 parameter)

¹ In IAD dryers, probe 1 is only used. Do not change this parameter

² This offset allows taking into account the effects of heat transfer between the probe and the measured environment. Do not change this parameter.

Purge Test

General

The purge needs to be tested during:

- the first commissioning
- routine inspections,
- the depressurization of the dryer for maintenance operations.

Operating procedure

1. Press the down arrow and hold for 1 second. Check that the solenoid valve opens and that the condensates drain away. Check that the purge icon is illuminated, on the controller interface.
2. The solenoid valve closes and the purging of the condensates stops.
3. Wait for 5 minutes and verify that the purge takes place properly again.
4. Correct the purge time if required by referring to §5.4

Note: The opened solenoid valve will close automatically at the end of the programmed purge duration.

SAFETY SYSTEM

The dryer has a safety system which disconnects the device when triggered.

Electrical circuit

The MOTOR PROTECTION allows disconnecting the dryer through the thermal relay when the air compressor operates under overload.

Restart

- 1) Resolve the problem that caused the device to shut down (refer to Corrective maintenance or contact MAT Ind).
- 2) Press the start button to restart the dryer.

ROUTINE MAINTENANCE

Daily maintenance

- **Check that the automatic purge normally evacuates the water and compressed air.**
- **Check that there are no air leaks on the inlet and outlet connections.**
- **Verify the temperature of the compressed air at the inlet and the ambient temperature are within operating parameters of the dryer specification.**
- **Clean the condenser of the dryer at regular intervals (once every two weeks).**

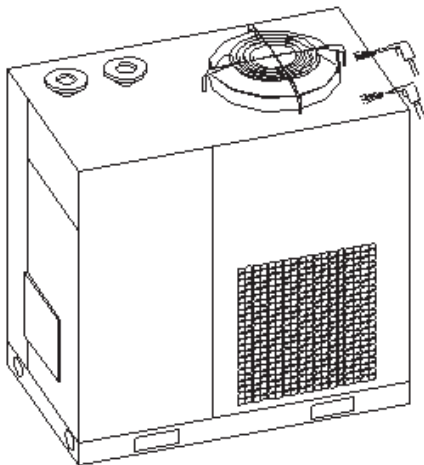

Maintenance

Clean the condenser regularly using a vacuum cleaner, brush or a compressed air gun. Dirty or plugged condenser coils will impact performance of the dryer and can lead to overheating of the compressor and possible shutdown and/or damage of the dryer.

Ensure that the blades and the thin aluminum plate of the condenser do not get bent out of shape while cleaning.

Condensate drain, strainer maintenance

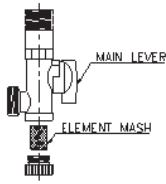

The locally installed strainer on the condensate drain helps to trap dirt. It is necessary to clean the Y-strainer depending on the quantity of the dirt present in the system to ensure proper operation. All our models from IAD15 - 45 are equipped with this Y-strainer.

Cleaning the drain Y-strainer*

General comments

The solenoid drain is protected by a Y strainer filter to prevent damage to the solenoid valve seals from metal particles or dust. This filter must be cleaned 1 week after the first start-up and then once per month. If this is not done, the filter will clog and it will not be possible to purge the system correctly. Liquid phase water will appear in the compressed air network.

Procedure

1. Close the manual valve on the purging line (see the refrigeration/pneumatic circuit diagram)
2. Unscrew the filter lock nut.
3. Withdraw the metal mesh, clean and refit.
4. Check the good condition of the seal and replace if necessary
5. Tighten the filter lock nut.
6. Open the manual valve on the purging line.

**You must comply with the recommendations at the beginning of this chapter.*

Solenoid valve maintenance*

General comments

The solenoid valve must always be protected by a filter to ensure that solid particles do not prevent it from opening and closing correctly. If particles do get through the filter and cause faulty operation of the solenoid purge valve, it must be dismantled and cleaned.

Procedure

1. Close the manual valve on the purging line (see refrigeration/pneumatic circuit diagram)
2. Disconnect the solenoid valve power supply
3. Disconnect the solenoid valve from the pipework and clamp it in a vice
4. Unscrew the coil lock nut and take it off the plunger
5. Unscrew the plunger from the valve seat
6. Check the O ring and the other components. Clean carefully.
7. Re-assemble the valve by reversing operations 1 to 5;

Do not over tighten the coil lock nut as this could prevent the valve from closing.

8. Refit the solenoid valve to the pipework, respecting the direction of the air flow indicated by an arrow on the body.
9. Reconnect the power supply to the solenoid purge valve.
10. Open the manual valve on the purging line

**You must comply with the recommendations at the beginning of this chapter.*

TROUBLESHOOTING IN THE EVENT OF MALFUNCTION

At normal working conditions, check the pressure gauge of the dryer as:

1) R-134a

Below 27 psi: Refill refrigeration gas if there is insufficient volume (check for any leakage).

Above 60 psi: Remove a certain volume of refrigeration gas if there is excessive volume (due to ambient temperature and air inlet temperature, because pressure increases if temperature is high).

Important!

The pointer of the pressure gauge can go out of the normal working range if there are defects in other parts of the device. The settings must be adjusted properly.

Consult MAT Industries, LLC or a qualified refrigeration technician for assistance.

Refrigerant handling in the US and Canada is only permitted by technicians with a valid refrigeration license.

CORRECTIVE MAINTENANCE

Refer to the table below if your dryer malfunctions.

Problem		Cause																
Solution		Refrigerant leakage	Improper functioning of the heating relay	Open by-pass valve	Light switches on instantly	Defective switch	Low voltage	Breakdown of the refrigerating compressor	Breakdown of the drain valve	Dirty drain valve	Very significant air flow	Low refrigerant charge	Breakdown of the hot gas valve	Blocked compressor	Very high ambient temperature	Breakdown of the fan	Breakdown of the compressor contactor	Breakdown of the ventilation pressure switch
The device does not start after pressing the Start button.	The power light does not switch on.					○	○	○										
	The power light switches on.					○		○										
There are condensates in the dryer outlet but the refrigerant pressure gauge indicates normal pressure								○	○	○							○	○
There are condensates in the dryer outlet but the refrigerant pressure gauge indicates high pressure		○	○	○	○				○								○	○
No condensates in the outlet of the drain solenoid valve													○					
The outlet air temperature is similar or hotter than the inlet air temperature									○						○	○	○	
Dryer stopped											○	○		○	○			
The high-pressure safety lamp is switched on		○	○	○	○											○	○	
The overcurrent safety lamp is switched on												○						
		Check for refrigerant leakage																
		Replacement																
		Close the by-pass valve																
		Replacement																
		Replacement																
		Use rated voltage																
		Replacement																
		Replacement																
		Dismantle and clean																
		Maintain rated air flow																
		Check for refrigerant leakage and refrigerating check																
		Replacement and adjustment of settings										○						
		Clean the condenser																
		Cool the ambient temperature																
		Replacement																
		Replacement																
		Replacement																

ARRANGEMENT DRAWINGS

IAD 15 - 45

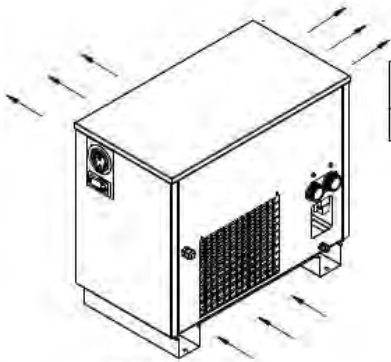

ISOMETRIC VIEW

MODEL	"A" mm./Inch	"B" mm./Inch	"C" mm./Inch	"D" mm./Inch	"E" mm./Inch	"F" mm./Inch	"G" mm./Inch
IAD 0015-0045	380 14,96	430 16,93	450 17,72	40 1,57	240 9,45	51 2,00	311 12,24

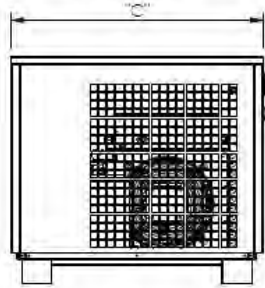

LEFT VIEW



FRONT VIEW

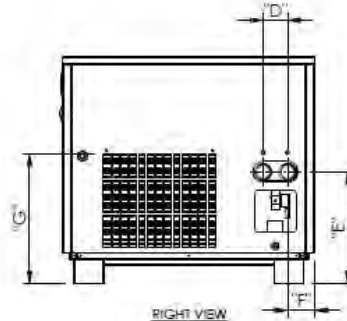

RIGHT VIEW

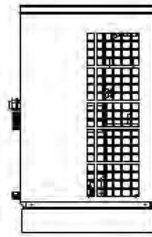

BACK VIEW

ELECTRICAL WIRINGS

IAD15 - 20 - 115V/1/60Hz

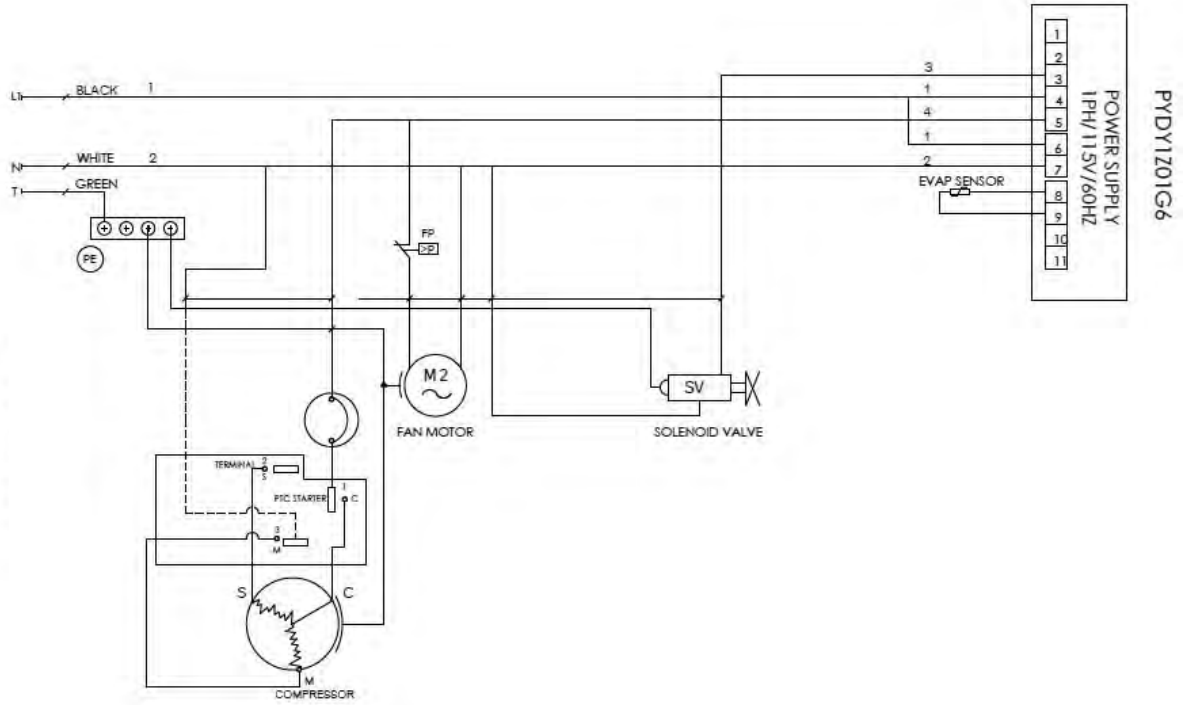

IAD30 - 45 - 115V/1/60Hz

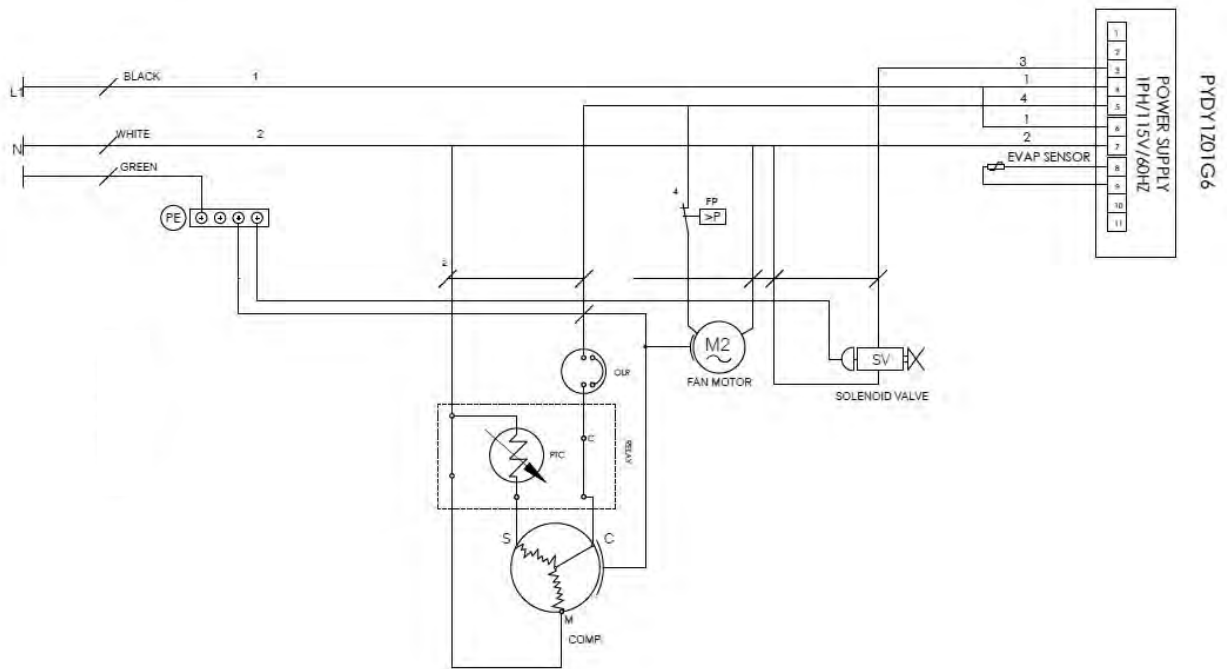

APPENDIXES

Model	Kw	A	W (in)	L (in)	H (in)	WORKING PRESS. (psi)	Connect	Weight (lb)
IAD15 - 115/1/60Hz	0.22	2.8	15.0	17.7	16.9	232	1/2"	55
IAD20 - 115/1/60Hz	0.23	2.9						62
IAD30 - 115/1/60Hz	0.24	3.0						71
IAD45 - 115/1/60Hz	0.25	3.1						77

These data may be changed by MAT Ind. without notice at any time.

PRODUCT NAME: REFRIGERANT GAS R134a

COMPOSITION/INFORMATION ON INGREDIENTS

CAS No.: 000811-97-2
EEC No.: 212-377-0

HAZARDOUS INGREDIENT(S)	CAS No.	Symbol	R Phrases
1,1,1,2-tetrafluoroethane (HFC 134a)	000811-97-2		

HAZARDS IDENTIFICATION

Low acute toxicity. High exposures may cause an abnormal heart rhythm and prove suddenly fatal. Very high atmospheric concentrations may cause anaesthetic effects and asphyxiation.
Liquid splashes or spray may cause freeze burns to skin and eyes.

FIRST-AID MEASURES

The first aid advice given for skin contact, eye contact, and ingestion is applicable following exposures to the liquid or spray. See also TOXICOLOGICAL INFORMATION.

Inhalation: Remove patient from exposure, keep warm and at rest. Administer oxygen if necessary. Apply artificial respiration if breathing has ceased or shows signs of failing. In the event of cardiac arrest apply external cardiac massage. Obtain immediate medical attention.

Skin Contact: Thaw affected areas with water. Remove contaminated clothing. Caution: clothing may adhere to the skin in the case of freeze burns. After contact with skin, wash immediately with plenty of warm water. If irritation or blistering occur obtain medical attention.

Eye Contact: Immediately irrigate with eyewash solution or clean water, holding the eyelids apart, for at least 10 minutes.
Obtain immediate medical attention.

Ingestion: Unlikely route of exposure.
Do not induce vomiting. Provided the patient is conscious, wash out mouth with water and give 200-300 ml (half a pint) of water to drink. Obtain immediate medical attention.

Further Medical Treatment

Symptomatic treatment and supportive therapy as indicated.

Adrenaline and similar sympathomimetic drugs should be avoided following exposure as cardiac arrhythmia may result with possible subsequent cardiac arrest.

FIRE-FIGHTING MEASURES

This refrigerant is not flammable in air under ambient conditions of temperature and pressure. Certain mixtures of this refrigerant and air when under pressure may be flammable. Mixtures of this refrigerant and air under pressure should be avoided.

Certain mixtures of HFCs and chlorine may be flammable or reactive under certain conditions.

Thermal decomposition will evolve very toxic and corrosive vapors. (hydrogen fluoride)

Containers may burst if overheated.

Extinguishing Media: As appropriate for surrounding fire. Water spray should be used to cool containers.

Fire Fighting Protective Equipment: A self-contained breathing apparatus and full protective clothing must be worn in fire conditions. See Also EXPOSURE CONTROLS/PERSONAL PROTECTION.

ACCIDENTAL RELEASE MEASURES

Ensure suitable personal protection (including respiratory protection) during removal of spillages. See Also EXPOSURE CONTROLS/PERSONAL PROTECTION.

Provided it is safe to do so, isolate the source of the leak. Allow small spillages to evaporate provided there is adequate ventilation.

Large spillages: Ventilate area. Contain spillages with sand, earth or any suitable adsorbent material. Prevent liquid from entering drains, sewers, basements and workpits since the vapor may create a suffocating atmosphere.

HANDLING AND STORAGE

HANDLING

Avoid inhalation of high concentrations of vapors. Atmospheric levels should be controlled in compliance with the occupational exposure limit. Atmospheric concentrations well below the occupational exposure limit can be achieved by good occupational hygiene practice.

The vapor is heavier than air, high concentrations may be produced at low levels where general ventilation is poor, in such cases provide adequate ventilation or wear suitable respiratory protective equipment with positive air supply.

Avoid contact with naked flames and hot surfaces as corrosive and very toxic decomposition products can be formed.

Avoid contact between the liquid and skin and eyes.

For correct refrigerant composition, systems should be charged using the liquid phase and not the vapor phase.

STORAGE

Keep in a well-ventilated place. Keep in a cool place away from fire risk, direct sunlight and all sources of heat such as electric and steam radiators.

Avoid storing near to the intake of air conditioning units, boiler units and open drains.

Cylinders and Drums:

Keep container dry.

Storage temperature (Deg C): < 45

EXPOSURE CONTROLS/PERSONAL PROTECTION

Wear suitable protective clothing, gloves and eye/face protection. Wear thermal insulating gloves when handling liquefied gases.

In cases of insufficient ventilation, where exposure to high concentrations of vapor is possible, suitable respiratory protective equipment with positive air supply should be used.

Occupational Exposure Limits

HAZARDOUS INGREDIENT(S)	TWA ppm	TWA mg/m ³	STEL ppm	STEL mg/m ³	
1,1,1,2- Tetrafluoroethane (HFC 134a)	1000	4240	-	-	OES

PHYSICAL AND CHEMICAL PROPERTIES

Form:	liquified gas
Color:	colorless
Odor:	slight ethereal
Boiling Point (Deg C):	-26.2
Vapor Pressure (mm Hg):	4270 at 20 Deg C
Density (g/ml):	1.22 at 20 Deg C
Solubility (Water):	insoluble
Solubility (Other): soluble in:	chlorinated solvents, alcohols, esters
Vapor Density (Air= 1):	3.66 at bubble point temperature

STABILITY AND REACTIVITY

Hazardous Reactions: Certain mixtures of HFCs and chlorine may be flammable or reactive under certain conditions.

Incompatible materials: finely divided metals, magnesium and alloys containing more than 2% magnesium.
Can react violently if in contact with alkali metals and alkaline earth metals -sodium, potassium, barium.

Hazardous Decomposition Product(s): hydrogen fluoride by thermal decomposition and hydrolysis.

TOXICOLOGICAL INFORMATION

Inhalation

High exposures may cause an abnormal heart rhythm and prove suddenly fatal. Very high atmospheric concentrations may cause anaesthetic effects and asphyxiation.

Skin Contact

Liquid splashes or spray may cause freeze burns. Unlikely to be hazardous by skin absorption.

Eye Contact

Liquid splashes or spray may cause freeze burns.

Ingestion

Highly unlikely - but should this occur freeze burns will result.

Long Term Exposure

A lifetime inhalation study in rats has shown that exposure to 50,000ppm resulted in benign tumors of the testis. The increased tumor incidence was observed only after prolonged exposure to high levels, and is considered not to be of relevance to humans occupationally exposed to HFC 134a at or below the occupational exposure limit.

ECOLOGICAL INFORMATION

Environmental Fate and Distribution

High tonnage material produced in wholly contained systems. High tonnage material used in open systems. Vapor.

Persistence and Degradation

Decomposed comparatively rapidly in the lower atmosphere (troposphere). Atmospheric lifetime is 13.6 year(s). Has a Halocarbon Global Warming Potential (HGWP) of 0.30 (relative to a value of 1 for CFC 11) or a Global Warming Potential (GWP) of 1300 (relative to a value of 1 for carbon dioxide at 100 years).

Effect on Effluent Treatment

Discharges of the product will enter the atmosphere and will not result in long term aqueous contamination.

DISPOSAL CONSIDERATIONS

Best to recover and recycle. If this is not possible, destruction is to be in an approved facility which is equipped to absorb and neutralise acid gases and other toxic processing products.

TRANSPORT INFORMATION

UN No.: 3159

AIR

ICAO/IATA

-primary: 2.2

SEA

IMDG

-primary: 2.2

Marine Pollutant: Not classified as a Marine Pollutant

Proper Shipping Name: 1,1,1,2-TETRAFLUOROETHANE

ROAD/RAIL

ADR/RID Class: 2

ADR/RID Item No: 2A

ADR Sin: 3159

REGULATORY INFORMATION

Not Classified as Hazardous to Users.

GLOSSARY

OES:	Occupational Exposure Standard (UK HSE EH40)
MEL:	Maximum Exposure Limit (UK HSE EH40)
COM:	The company aims to control exposure in its workplace to this limit
TLV:	The company aims to control exposure in its workplace to the ACGIH limit
TLV-C:	The company aims to control exposure in its workplace to the ACGIH Ceiling limit
MAK:	The company aims to control exposure in its workplace to the German limit
Sk:	Can be absorbed through skin
Sen:	Capable of causing respiratory sensitization
Bmgv:	Biological monitoring guidance value (UK HSE EH40)
ILV:	Indicative Limit Value (UK HSE EH40)

REMARKS
