

Installation, Operation and Maintenance Instructions for Models 2340, 2475, 2545, 7100, 15T & 3000 Two-Stage Reciprocating Air Compressors

IMPORTANT INFORMATION! READ AND FOLLOW THESE INSTRUCTIONS. RETAIN FOR REFERENCE.

SAFETY

DEFINITIONS

- △ **DANGER** WILL cause DEATH, SEVERE INJURY or substantial property damage.
- △ **WARNING** CAN cause DEATH, SEVERE INJURY or substantial property damage.
- △ **CAUTION** WILL or CAN cause MINOR INJURY or property damage.

GENERAL SAFETY PRECAUTIONS

- △ **DANGER** **INTAKE AIR.** Can contain carbon monoxide or other contaminants. Will cause serious injury or death. Ingersoll-Rand air compressors are not designed, intended or approved for breathing air. Compressed air should not be used for breathing air applications unless treated in accordance with all applicable codes and regulations.
- △ **WARNING** **HAZARDOUS VOLTAGE.** Can cause serious injury or death. Disconnect power and bleed pressure from the tank before servicing. Lockout/Tagout machine. Compressor must be connected to properly grounded circuit. See grounding instructions in manual. Do not operate compressor in wet conditions. Store indoors.
MOVING PARTS. Can cause serious injury. Do not operate with guards removed. Machine may start automatically. Disconnect power before servicing. Lockout/Tagout machine.
HOT SURFACES. Can cause serious injury. Do not touch. Allow to cool before servicing. Do not touch hot compressor or tubing.
HIGH PRESSURE AIR. Bypassing, modifying or removing safety/relief valves can cause serious injury or death. Do not bypass, modify or remove safety/relief valves. Do not direct air stream at body. Rusted tanks can cause explosion and severe injury or death. Drain tank daily or after each use. Drain valve located at bottom of tank.
- △ **CAUTION** **RISK OF BURSTING.** Use only suitable air handling parts acceptable for pressure of not less than the maximum allowable working pressure of the machine.

GENERAL INFORMATION

INTRODUCTION

This manual provides safe and reliable instructions for the installation, operation and maintenance of your Ingersoll-Rand air compressor. Carefully read this manual before attempting to operate or perform any maintenance. If you are uncertain about any of the instructions or procedures provided in this manual, contact Ingersoll-Rand. We recommend you retain this manual, and all publications provided with your air compressor, in a location which is accessible to all personnel who operate and service your compressed air equipment.

APPLICATION

Ingersoll-Rand's standard two-stage lubricated air compressors are single-acting, air-cooled machines. Typical compressors are furnished as compact, self-contained, air receiver tank mounted units that are automatically regulated and driven by an electric motor or gasoline engine. An air-cooled aftercooler, low oil level shutdown switch and automatic drain valve are among the optional accessories that can be furnished. Bare compressor pumps and baseplate-mounted units are also available.

These compressors may be used for a variety of compressed air application up to 250 PSIG (17.5 kg/cm²). Application of these compressors as either a primary or supplementary source of air is virtually unlimited in industrial plants, service stations and auto repair shops. Supplementary service includes such uses as furnishing air at pressure not carried in regular shop lines, air at isolated locations, and standby service for air when larger compressors are shut down.

TWO-STAGE OPERATION

Two-stage compressors consist of one or two first-stage cylinders with the same bore size and one second-stage cylinder with a smaller bore size.

Typical Two-Stage, Two Cylinder Unit



Typical Two-Stage, Three Cylinder Unit



The basic principle of operation is as follows: On the suction stroke of the first-stage piston(s), air at atmospheric pressure enters the cylinders through the inlet filter(s) and then the inlet valves located in the head. On the compression stroke of the first-stage piston(s), the air is compressed to an intermediate pressure and discharged through the discharge valves(s) into common manifold(s). From the manifold(s) the air passes through the intercooler tubes, where the heat of first-stage compression is removed. On the suction stroke of the second-stage piston this cooled air enters the second-stage cylinder through the inlet valve. The compression stroke of the second-stage piston compresses the air to the final discharge pressure and forces it out through the discharge valve into the receiver tank or system. If cooling of the discharge air is required, an air-cooled aftercooler should be installed between the compressor discharge and the receiver tank or system.

For maintaining the receiver tank or system air pressure within predetermined limits, the compressor may be operated with automatic start & stop control or constant speed control regulation. The type of regulation used depends upon the application.

ADDITIONAL REFERENCES

Unless otherwise stated, dimensions, weights and measurements are provided in standard U.S. measure followed in parentheses by the metric conversion. Any torque values given are stated in inch or foot pounds followed by the Newton-meter equivalent in parentheses. Electrical characteristics are given in voltage-phase-hertz.

RECEIPT & INSPECTION

Ensure adequate lifting equipment is available for unloading and moving the unit to the installation site.

- NOTE** Lifting equipment must be properly rated for the weight of the unit.
- △ **CAUTION** Lift the unit by the shipping skid only. Do not use the motor lifting eye to lift the entire unit. The motor lifting eye is for removing the motor from the unit only.
- △ **CAUTION!** Do not work on or walk under the unit while it is suspended.

Before signing the delivery receipt, inspect for damage and missing parts. If damage or missing parts are apparent, make the appropriate notation on the delivery receipt, then sign the receipt. Immediately contact the carrier for an inspection.

All material must be held in the receiving location for the carrier's inspection.

Delivery receipts that have been signed without a notation of damage or missing parts are considered to be delivered "clear." Subsequent claims are then considered to be concealed damage claims. Settle damage claims directly with the transportation company.

If you discover damage after receiving the unit (concealed damage), the carrier must be notified within 15 days of receipt and an inspection must be requested by telephone with confirmation in writing. On concealed damage claims, the burden of establishing that the unit was damaged in transit reverts back to the claimant.

Read the unit nameplate to verify it is the model ordered, and read the motor nameplate to verify it is compatible with your electrical conditions. Make sure electrical enclosures and components are appropriate for the installation environment.

INSTALLATION

SELECTING A LOCATION

ELECTRIC MOTOR UNITS. For most electric motor units, select a relatively clean and dry well-lighted indoor area with plenty of space for proper ventilation, cooling air flow and accessibility. Provide 1,000 cubic feet of fresh air per 5 horsepower. Locate the unit at least 15 inches (38 cm) from walls, and make sure the main power supply is clearly identified and accessible.

Unless the electrical components of the unit are specially protected for outdoor use, do not install an electric motor unit outdoors or in an area that will expose the electrical components to rain, snow or sources of appreciable moisture.

WARNING FOR UNITS EQUIPPED WITH ELECTRIC DRAIN VALVE

- △ **WARNING** The electric drain valve incorporates arcing or sparking parts, such as snap switches, receptacles and the like that tend to produce arcs or sparks and, therefore, when located in a garage, the compressor should be in a room or enclosure provided for the purpose, or the electric drain valve should be 18 inches (457 mm) or more above the floor.

GASOLINE ENGINE UNITS. For gasoline engine units, keep the engine at least 3 feet (1 m) away from building walls and other equipment. Install the unit in a location with plenty of space for proper ventilation, cooling air flow and accessibility. Do not install or operate a gasoline engine unit in a confined area.

AMBIENT TEMPERATURE CONSIDERATIONS. Ideal operating temperatures are between 32°F and 100°F (0°C and 37.8°C). If temperatures consistently drop below 32°F (0°C), install the compressor in a heated area. If this is not possible, you must protect safety/relief valves and drain valves from freezing. If temperatures are consistently below 40°F (4.4°C), consider installing an external crankcase heater kit, especially if the compressor has difficulty starting.

- △ **CAUTION** Never operate the compressor in temperatures below -15°F (-26.1°C) or above 125°F (51.0°C).

HUMID AREAS. In frequently humid areas, moisture may form in the pump and produce sludge in the lubricant, causing running parts to wear out prematurely. Excessive moisture is especially likely to occur if the unit is located in an unheated area that is subject to large temperature changes.

Two signs of excessive humidity are external condensation on the pump when it cools down and a "milky" appearance in petroleum lubricant.

You may be able to prevent moisture from forming in the pump by increasing ventilation, operating for longer intervals or installing an external crankcase heater kit.

NOISE CONSIDERATIONS. Consult local officials for information regarding acceptable noise levels in your area. To reduce excessive noise, use vibration isolator pads or intake silencers, relocate the unit or construct total enclosures or baffle walls.

MOUNTING

⚠ **WARNING** Remove the unit from the skid before mounting.

ELECTRIC MOTOR UNITS. Bolt the unit to a firm, level foundation (such as a concrete floor). Do not bolt uneven feet tightly to the foundation, as this will cause excessive stress on the receiver tank. Use metal shims under the "short" feet if necessary.

Typical Permanent Mounting (Customer Supplied Hardware)

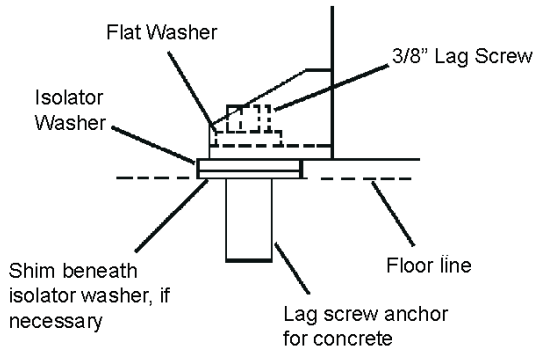

GASOLINE ENGINE UNITS. Bolt the unit to a firm, level foundation. Do not bolt uneven feet tightly to the foundation, as this will cause excessive stress on the receiver tank. Use metal shims under the "short" feet if necessary. Gasoline engine units mounted on truck beds must be fastened securely without applying excessive stress on the receiver tank. We recommend installing a vibration isolator kit with gasoline engine models.

INSTALLING REMOTE AIR INLET PIPING

⚠ **CAUTION** Do not operate the unit without air inlet filtration.

If the air around the unit is relatively free of dirt, install the air inlet filter at the inlet connection at the pump. If the air is dirty, pipe the filter to a source of clean air. Use PVC plastic tubes for remote inlet piping. Do not use black pipe or galvanized pipe, as these promote sweating and rust. Consider installing an in-line type filter for ease of cleaning and replacement. Make the line as short and direct as possible and as large, or larger, than the diameter of the inlet connection on the pump. Do not install piping with a diameter lower than that of the pump intake.

Increase the pipe diameter one size for every 10 feet (3 m) of length or every 90° bend. Make sure the piping is adequately braced.

If you pipe the filter outdoors, cover it with a hood to prevent the entrance of rain or snow.

Heavy duty filter elements and filtration equipment are available for fine airborne dust, such as cement and rock dust.

Typical Remote Air Inlet Piping.

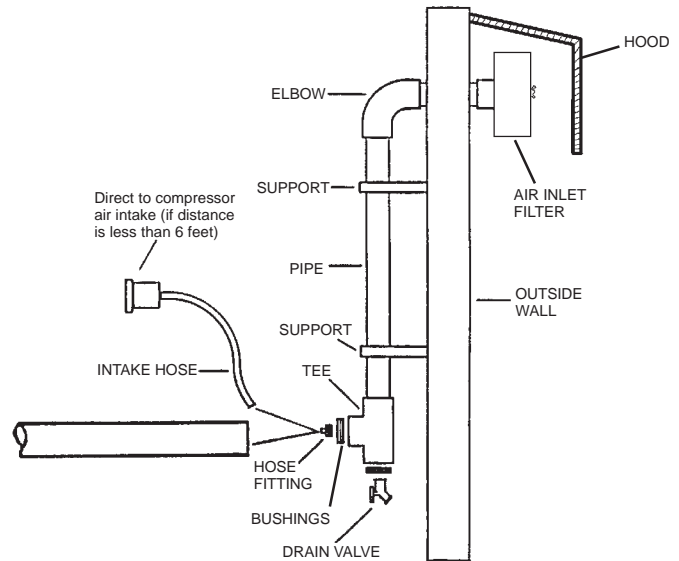

INSTALLING DISCHARGE PIPING

⚠ **WARNING** Do not use plastic pipe, soldered copper fittings, rubber hose, or lead-tin soldered joints anywhere in the compressed air system.

⚠ **CAUTION!** If you will be using synthetic compressor lubricant, all downstream piping material and system components must be compatible. Refer to the following material compatibility list. If there are incompatible materials present in your system, or if there are materials not included in the list, contact Ingersoll-Rand for recommendations.

SYNTHETIC COMPRESSOR LUBRICANT MATERIAL COMPATIBILITY LIST

SUITABLE

Viton®, Teflon®, Epoxy (Glass Filled), Oil Resistant Alkyd, Fluorosilicone, Fluorocarbon, Polysulfide, 2-Component Urethane, Nylon, Delrin®, Celcon®, High Nitrile Rubber (Buna N. NBR more than 36% Acrylonitrile), Polyurethane, Polyethylene, Epichlorohydrin, Polyacrylate, Melamine, Polypropylene, Baked Phenolics, Epoxy, Modified Alkyds
(® indicates trademark of DuPont Corporation)

NOT RECOMMENDED

Neoprene, Natural Rubber, SBR Rubber, Acrylic Paint, Lacquer, Varnish, Polystyrene, PVC, ABS, Polycarbonate, Cellulose Acetate, Low Nitrile Rubber (Buna N. NBR less than 36% Acrylonitrile), EPDM, Ethylene Vinyl Acetate, Latex, EPR, Acrylics, Phenoxy, Polysulfones, Styrene Acrylonitrile (San), Butyl

NOTE All compressed air systems generate condensate which accumulates in any drain point (e.g. tanks, filters, drip legs, aftercoolers, dryers). This condensate contains lubricating oil and/or substances which may be regulated and must be disposed of in accordance with local, state, and federal laws and regulations.

GENERAL REQUIREMENTS. The piping, fittings, air receiver tank, etc. must be certified safe for at least the maximum working pressure of the unit. Use hard-welded or threaded steel or copper pipes and cast iron fittings that are certified safe for the unit's discharge pressure and temperature. **DO NOT USE PVC PLASTIC IN THE COMPRESSED AIR DISCHARGE LINE.** Use pipe thread sealant on all threads, and make up joints tightly to prevent air leaks.

CONDENSATE DISCHARGE PIPING. If installing a condensate discharge line, the piping must be at least one size larger than the connection, as short and direct as possible, secured tightly and routed to a suitable drain point or waste container. Condensate must be disposed of in accordance with local, state, and federal laws and regulations.

△ WARNING If an aftercooler, check valve, block valve, or any other restriction is added to the compressor discharge, install a properly-sized ASME approved safety/relief valve between the compressor discharge and the restriction.

INSTALLING ELECTRICAL WIRING (ELECTRIC MOTOR UNITS)

△ WARNING Electrical installation and service should be performed by a qualified electrician who is familiar with all applicable local, state and federal laws and regulations.

GENERAL. The motor rating, as shown on the motor nameplate, and the power supply must have compatible voltage, phase and hertz characteristics.

WIRE SIZE. The electrical wiring between the power supply and electric motor varies according to motor horsepower and other factors. Install adequately sized power leads to protect against excessive voltage drop during start-up. Refer to the National Electric Code (NEC) for information on selecting the proper wire size and securing electrical connections. If you connect additional electrical equipment to the same circuit, consider the total electrical load when selecting the proper wire size. **DO NOT USE UNDERSIZE WIRE.**

If wire size information is not available, the wire sizes shown in the following wire selection chart can be used as a safe guide, if the distance does not exceed 50 feet (15.3 m). For longer distances, consult an electrical contractor or the local electric company for recommendations.

MOTOR HP	SINGLE PHASE		THREE PHASE			
	115V	230V	200V	230V	460V	575V
1	12	14	14	14	14	14
1.5	10	14	14	14	14	14
2	8	14	14	14	14	14
3	8	12	14	14	14	14
5	4	8	10	12	14	14
7.5		6	8	10	14	14
10			8	8	12	14
15			4	6	10	10
20			3	4	8	10
25			1	2	6	8
30			0	1	6	8

MAGNETIC STARTER. If the motor installed on your unit has a motor reset button, it does not require a magnetic starter. If the motor does not have this button and the unit does not have a factory-installed starter, install a magnetic starter with thermal overload protection. Follow the manufacturer's instructions for installation. Ingersoll-Rand cannot accept responsibility for damages arising from failure to provide adequate motor protection.

FUSES. Refer to the NEC to determine the proper fuse or circuit breaker rating required. When selecting fuses, remember the momentary starting current of an electric motor is greater than its full load current. Time-delay or "slow-blow" fuses are recommended.

PRESSURE SWITCH. On units without a factory-installed pressure switch, wire a pressure switch in accordance with the appropriate wiring schematic in the DIAGRAMS section of this manual. Mount the pressure switch in accordance with the manufacturer's recommendations. The connecting line to the receiver tank must be as short and direct as possible, and certified safe for at least the maximum working pressure of the unit.

CONNECTING A BATTERY (GASOLINE ENGINE UNITS)

NOTE If you will be making connections to a remote battery, the engine on the compressor unit must be equipped with an alternator.

BATTERY. A 12 volt battery with a minimum current rating of 250 CCA (cold cranking amps) and minimum ampere-hour rating of 24 Ah should be sufficient for cranking most electric start engines.

BATTERY CABLES. Refer to the following table for size and length recommendations.

Cable Size (GA)	Maximum Length
6	5' (1.5 m.)
4	7'-2.5" (2.1 m.)
2	12' (3.6 m.)

CONNECTION PROCEDURES:

1. Connect the battery positive (+) cable (A) to the starter solenoid terminal (B).

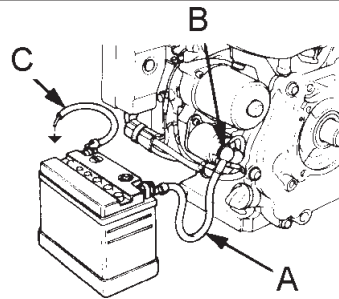

2. Connect the battery negative (-) cable (C) to the bolt shown in the following illustration. Secure the wire in place by screwing a suitably-sized nut onto the bolt and down onto the terminal.

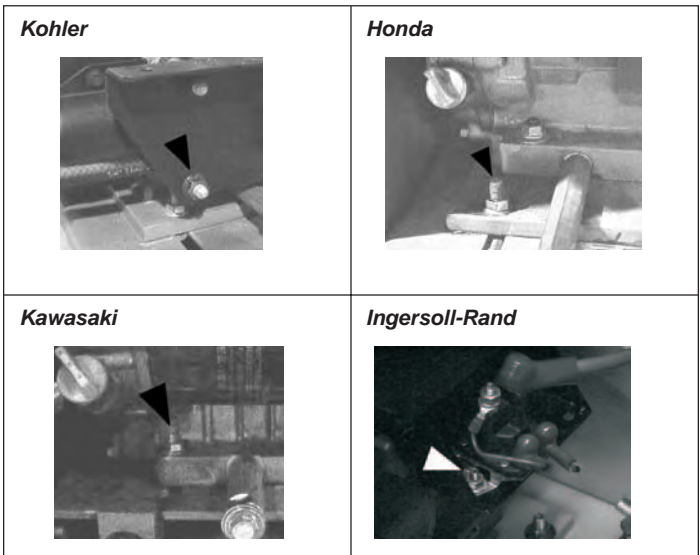

3. Connect the battery positive (+) cable (A) to the battery positive (+) terminal.
4. Connect the battery negative (-) cable to the battery negative (-) terminal.
5. Coat the terminals and cable ends with corrosion-preventive grease.

⚠ WARNING Remove the cable from the negative (-) side of the battery before servicing.

Refer to the engine manufacturer's instructions for more information.

FUEL PUMP INSTALLATION (GASOLINE ENGINE UNITS)

Some engines use an optional fuel pump to supply gasoline to the engine directly from a vehicle's onboard fuel system. Install the fuel pump within 12 inches (30 cm) of the bottom surface of the vehicle's fuel tank. Protect the pump from contamination by installing a fuel isolation valve and an inline filter between the pump fuel system.

COMPRESSOR LUBRICATION

⚠ CAUTION Do not operate without lubricant or with inadequate lubricant. Ingersoll-Rand is not responsible for compressor failure caused by inadequate lubrication.

SYNTHETIC COMPRESSOR LUBRICANT. Ingersoll-Rand recommends All Season Select synthetic lubricant from start-up. See the WARRANTY section for extended warranty information.

ALTERNATE LUBRICANTS. You may use XL-300 or a comparable petroleum-based lubricant that is premium quality, does not contain detergents, contains only anti-rust, anti-oxidation, and anti-foam agents as additives, has a flashpoint of 440°F (227°C) or higher, and has an auto-ignition point of 650°F (343°C) or higher.

See the petroleum lubricant viscosity table below. The table is intended as a general guide only. Heavy duty operating conditions require heavier viscosities. Refer specific operating conditions to Ingersoll-Rand for recommendations.

Temperature Around Compressor		Viscosity @ 100°F (37.8°C)		Viscosity Grade	
°F	°C	SUS	Centistokes	ISO	SAE
< 40	< 4.4	150	32	32	10
40-80	4.4-26.7	500	110	100	30
80-125	26.7-51.0	750	165	150	40

If you use a petroleum-based compressor lubricant at start-up and decide to convert to All Season Select later on, the pump must be decarbonized and flushed before conversion. Contact Ingersoll-Rand for more information.

FILLING PROCEDURES:

1. Unscrew and remove the oil fill plug.
2. Fill the crankcase with lubricant.
3. Replace the oil fill plug **HAND TIGHT ONLY**.

⚠ CAUTION Do not remove the oil fill plug while the compressor is running.

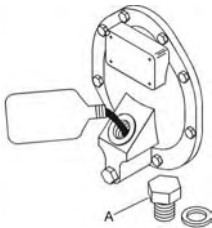

Refer to the following table for crankcase capacity.

Model	Crankcase Capacity
2340	28 oz. (827 ml.)
2475	41 oz. (1212 ml.)
2545	73 oz. (2158 ml.)
7100	80 oz. (2365 ml.)
15T, 3000	144 oz. (4258 ml.)

Use one of the following methods illustrated to determine when the crankcase is full.

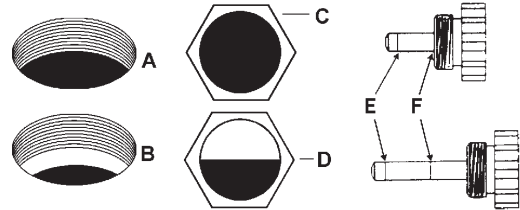

A = FULL level at bottom thread of oil fill opening on units without sight glass or dipstick.

B = ADD level below bottom thread of oil fill opening on units without sight glass or dipstick.

C = FULL level on units with sight glass.

D = ADD level on units with sight glass.

E = ADD level on units with dipstick.

F = FULL level on units with dipstick.

LOW OIL LEVEL SWITCH

A float activated low oil level switch may be installed to protect your unit against damage due to insufficient compressor oil level. Low oil level in the compressor crankcase causes the switch contacts to open, thus shutting the unit down until the proper oil level has been restored.

Proper protection against low oil level depends on proper adjustment of the low oil level switch. During the initial run, stop the unit and drain one quart of oil from the compressor crankcase into a suitable clean container. Listen for the switch to click or check the switch with a continuity tester.

The float sometimes gets cocked or stuck during shipping. If the float is cocked or stuck, open the disconnect switch, drain the remaining oil, remove the crankcase cover and then free the float. Reassemble and then reuse the same oil.

NOTE If the float is cocked in the low position, the unit cannot start.

OPERATION

INTERMITTENT DUTY FORMULA

Units operating above 200 PSIG are to be operated according to the "Intermittent Duty Formula."

INTERMITTENT DUTY FORMULA

Pump-up time should not ordinarily exceed thirty (30) minutes or be less than ten (10) minutes. Shutdown periods between cycles of operation should be at least equal to the pump-up time. Note: When the compressor is regulated by constant speed control, the shutdown period is the time the compressor is operating unloaded.

A pump-up time limit with the following cool-down period is recommended to protect the valves and heads against stabilized high operating temperatures, which could rapidly build up carbon in these areas.

All inquiries for high-pressure compressor application where the "use" cycle differs from the "Intermittent Duty Formula" should be referred to Ingersoll-Rand.

START-UP (ELECTRIC MOTOR DRIVEN MODELS)

1. Close the service valve.
2. Release any remaining tank pressure by slowly opening the manual drain valve.
3. Close the manual drain valve and apply power to the compressor. If the pressure switch is equipped with an "ON/AUTO-OFF" lever, flip the switch to the "ON/AUTO" position. If the unit is equipped with a control panel "ON/OFF" switch, move the switch to the "ON" position.

Typical Pressure Switch Lever (If Equipped)

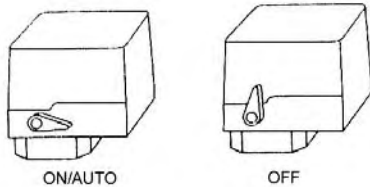

4. Slowly open the service valve.

Typical Service Valve (A = Open, B = Closed)

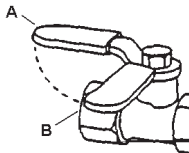

CAUTION Unusual noise or vibration indicates a problem. Do not continue to operate until you identify and correct the source of the problem.

NOTE Ensure the direction of rotation is correct per the arrow on the motor. If the rotation is incorrect on three-phase units, interchange any two of the three leads.

START-UP (GASOLINE ENGINE UNITS)

WARNING Do not operate gasoline engine units in an enclosed area.

1. Release any remaining tank pressure by slowly opening the manual drain valve.
2. Turn on the engine gasoline supply.
3. Put the choke in the "on" position.
4. Close the service valve and put the unloader lever in the "unload" (A) position for Kawasaki and Honda engine driven models, or the "load" (B) position for Kohler engine driven models.
5. Start the engine, release the choke, and allow the engine to warm up for two to three minutes.
6. Return the unloader lever to the "load" (B) position on Kawasaki and Honda engine driven models.

Typical Unloader (A = Unload, B = Load)

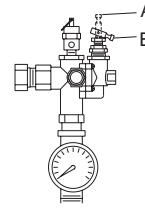

NOTE Turn the gasoline supply off when the compressor is not being used.

NOTE Some gasoline engine driven compressors require 5-8 break-in hours of operation before reaching full capacity and speed.

COMPRESSOR CONTROLS

AUTOMATIC START & STOP CONTROL. This type of control applies to electric motor driven models under 10 horsepower.

NOTE Automatic Start & Stop Control is intended for use when the motor will start no more than 6 times per hour.

When the receiver tank pressure reaches the factory pre-set maximum pressure (usually 175 PSIG), the pressure switch stops the unit. When the receiver tank pressure drops below the factory pre-set minimum (usually 135 PSIG), the pressure switch resets and restarts the unit.

CONSTANT SPEED CONTROL. This type of control applies to gasoline engine units.

When the receiver tank pressure reaches the factory pre-set maximum pressure (usually 175 PSIG), the unloader slows down the engine and the unit stops pumping. When the receiver tank pressure drops to the factory pre-set minimum (usually 145 PSIG), the unloader resets, the engine returns to full speed, and the unit resumes pumping.

DUAL CONTROL. This type of control applies to electric motor units over 10 horsepower. Select either automatic start and stop control or constant speed control by adjusting the knob on the auxiliary valve. For automatic start and stop control, turn the knob on the auxiliary valve fully clockwise to disable the auxiliary valve. The pressure switch will then start and stop the unit.

NOTE For dual control models, automatic start and stop is preferred.

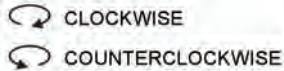
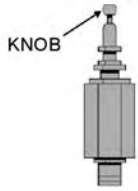
Auxiliary Valve.

Select constant speed control if the unit restarts in less than 10 minute intervals or runs more than 40 minutes per hour. Turn the knob fully counterclockwise to run the unit continually. When the receiver tank pressure reaches 170 PSIG, the unit runs but does not pump.

NOTE The auxiliary valve is factory pre-set at 5 PSIG lower than the factory pressure switch setting.

△ CAUTION Running unloaded for more than 20 minutes per hour or more than 15 minutes continually with the use of constant speed control will cause oil pumping and should be avoided.

PRESSURE SWITCH ADJUSTMENT

△ WARNING High voltage is present at the pressure switch contacts when the power supply is connected. Disconnect, lock and tag main power supply before making adjustments.

△ CAUTION Do not adjust the pressure switch to exceed the maximum discharge pressure of the unit.

NOTE Adjust the pressure switch only if adjustments are absolutely necessary.

CUT-IN & CUT-OUT. The cut-out (compressor shut-down) is the pressure at which the switch contacts open, and the cut-in (compressor restart) is the pressure at which the switch contacts close. See COMPRESSOR CONTROLS.

ADJUSTMENT CONTROLS. All pressure switches have a range adjustment control (A). Some pressure switches also have a differential adjustment (B) control. On switches without a differential adjustment control, the span between cut-in and cut-out pressure levels switches is factory set for 40 ± 4 PSIG and cannot be adjusted.

NOTE Some pressure switches are equipped with an on-off lever used to open and close the electrical contacts inside the switch. **THIS LEVER IS NOT A DIFFERENTIAL ADJUSTMENT CONTROL.** The pressure switches with the on-off lever do not have a differential adjustment control.

ADJUSTMENT PROCEDURES (SWITCHES WITHOUT DIFFERENTIAL ADJUSTMENT CONTROL):

1. Remove the pressure switch cover.
2. Adjust the range by turning the range adjustment screw clockwise (in) to increase the cut-out point or counter-clockwise (out) to decrease the cut-out point.

NOTE: One full turn changes the setting approximately 2 PSIG.

3. Replace cover, reconnect power supply and start the compressor.
4. Note the pressure gauge reading at which the compressor cuts out.
5. Repeat adjustment procedure if necessary.

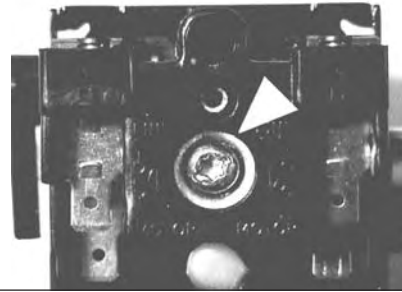
Pressure Switch Range Adjustment.**ADJUSTMENT PROCEDURES (SWITCHES WITH DIFFERENTIAL ADJUSTMENT CONTROL):**

1. Remove the pressure switch cover.
2. Set the cut-in pressure with the range adjustment nut. Turn the nut clockwise (in) to increase the pressure or counter-clockwise (out) to decrease the pressure.

NOTE: One full turn changes the setting approximately 2 PSIG.

3. Set the cut-out pressure with the differential adjustment. Turn the differential adjustment nut clockwise (in) to increase the pressure or counter-clockwise (out) to decrease the pressure.

NOTE: One full turn changes the setting approximately 2 PSIG.

4. Replace the cover, reconnect the power supply and start the unit.
5. Note the pressure gauge reading at which the unit cuts out.
6. Repeat the adjustment procedure if necessary.

The minimum possible differential is approximately 20% of cutout pressure. It is advisable to have as wide a differential as possible to avoid frequent starting and stopping of the unit. Note the pressure gauge reading at which the unit cuts-out and re-establish this point if necessary.

Note the interaction between the range and differential adjustments, i.e., if the cut-out is increased, the differential will also increase, or if the differential is narrowed, the cut-out will be reduced, etc. These factors must be considered when adjusting the switch and compensated for accordingly.

STARTING UNLOADING SYSTEM

The starting unloading feature exists on certain models. The purpose of the system is to relieve cylinder pressure when the unit stops, permitting it to start against a light load. A light load increases the life of the driver and belts and also reduces the possibility of tripping the overload relay. The system operates in the following manner:

The centrifugal unloader is attached to the end of the crankshaft as shown in the following illustrations.

When the unit starts, centrifugal force acts upon the unloader weights and they swing outward. This permits the plunger and thrust pin to move inward and the pilot valve to close. The escape path to atmosphere for the cylinder pressure is now closed and the compressor pumps air in a normal manner.

When the unit stops, the weights retract, permitting the thrust pin spring to move the plunger and thrust pin outward. The thrust pin opens the pilot valve and the trapped air pressure escapes from the cylinder and intercooler through a passage in the frame end cover, through the unloader tube and to atmosphere through the inlet filter/silencer.

Position of weight and thrust pin when unit is operating.

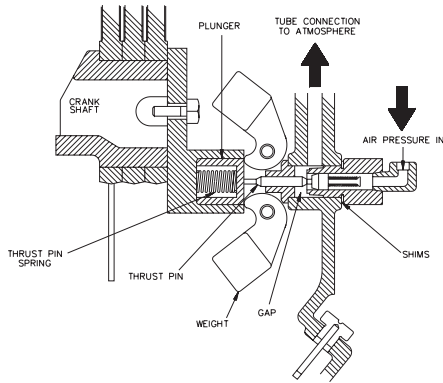

Position of weight and thrust pin when unit is stopped.

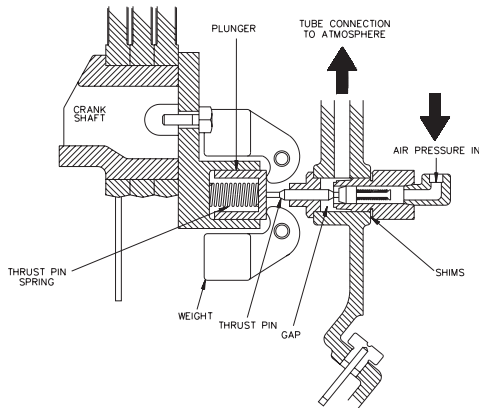

PILOT VALVE ADJUSTMENT

If the pilot valve tube line is excessively hot, it is a good indication that the pilot valve is leaking and adjustment is required.

To adjust the pilot valve, proceed as follows:

1. Stop the unit and disconnect and tag the electrical supply main switch to prevent accidental start-up.
2. Remove the pilot valve tube and the tube fittings.
3. Remove the pilot valve body and all existing shims.
4. Screw the pilot valve body back into the frame end cover (without any shims) until contact with the thrust pin is felt. Advance the pilot valve body 1/4 to 1/2 turn more.

If contact with the thrust pin cannot be felt, the following steps may be necessary to locate the contact point:

1. Insert a small instrument (punch, rod, nail, etc.) into the end of the pilot valve until it contacts the valve stem.
2. While still inserted in the pilot valve, make a mark on the instrument even with the outside edge of the pilot valve body.
3. Keeping the instrument pressed lightly against the valve stem, screw the pilot valve body into the frame end cover. When the mark on the instrument starts moving out away from the edge of the pilot valve body, contact has been made with the thrust pin.
4. Advance the pilot valve body 1/4 to 1/2 turn more and proceed with step five.
5. Measure the gap between the pilot valve body and the frame end cover.
6. Remove the pilot valve body and add enough shims to fill the gap measured in step five.
7. Screw the pilot valve body back into the frame end cover until the body is tight on the shims.
8. Reconnect the pilot valve tube and tube fittings.

BREATHER/UNLOADER BY-PASS

The breather/unloader by-pass tube lines eliminates air pressure build-up in the compressor frame by providing a passage for the air to escape through the inlet unloader (if opened) or (if closed) through the check valve, therefore, by-passing the inlet unloader and escaping to atmosphere through the inlet filter/silencer.

OIL CONSUMPTION CHECK

A rule of thumb in determining a "passing grade" for oil consumption is to consider consumption at or above 50 horsepower-hours per ounce to be acceptable.

The formula is as follows:

$$\frac{\text{Horsepower} \times \text{Hours of Operation}}{\text{Ounces of Oil Used}} = \text{Horsepower Hours per Ounce}$$

To apply this formula, consider the size of the machine. In the following example, a 5 horsepower compressor uses 2 ounces of oil every 20 hours of operation.

$$\frac{5 \text{ Horsepower} \times 20 \text{ Hours of Operation}}{2 \text{ Ounces of Oil Used}} = 50 \text{ Horsepower Hours per Ounce}$$

The compressor in the example passes the oil consumption test.

NOTE New or rebuilt compressor pumps will discharge higher than normal amounts of oil until the piston rings are seated (approximately 100 operating hours).

MAINTENANCE

⚠ WARNING Before performing maintenance, release air pressure from the system and disconnect, lock and tag the main power supply or disconnect the wire from the engine spark plug.

NOTE All compressed air systems contain maintenance parts (e.g. lubricating oil, filters, separators) which are periodically replaced. These used parts may be, or may contain, substances that are regulated and must be disposed of in accordance with local, state, and federal laws and regulations.

NOTE Take note of the positions and locations of parts during disassembly to make reassembly easier. The assembly sequences and parts illustrated may differ for your particular unit.

NOTE Any service operations not explained in this manual should be performed by an authorized service representative.

NOTE Reference the engine owner's manual for engine care information.

NOTE The following maintenance schedule has been developed for typical applications. Maintenance intervals should be shortened in harsher environments.

MAINTENANCE SCHEDULE

Daily or Before Each Operation	<ul style="list-style-type: none"> ● Check for oil leaks. ● Check lubricant level. Fill as needed. ● Drain receiver tank condensate (if automatic draining device is not provided). Open manual drain valve and collect and dispose of condensate accordingly. ● Check for unusual noise and vibration. ● Ensure beltguards and covers are securely in place. ● Ensure engine (if supplied) is filled with fuel and lubricant according to the manufacturer's recommendations. ● Ensure area around compressor is free from rags, tools, debris, and flammable or explosive materials.
Weekly	<ul style="list-style-type: none"> ● Observe operation of safety/relief valves while the compressor is running. Replace safety/relief valves that do not operate freely. ● Inspect air filter element(s). Clean if necessary.
Monthly	<ul style="list-style-type: none"> ● Inspect for air leaks. Squirt soapy water around joints during compressor operation and watch for bubbles. ● Check tightness of screws and bolts. Tighten as needed. ● Inspect drive belts. Adjust if necessary. ● Clean exterior.
3/500 *	<ul style="list-style-type: none"> ● Change petroleum lubricant while crankcase is warm.
12/2000 *	<ul style="list-style-type: none"> ● Drain compressor oil and clean oil sight glass ● Install maintenance pak — or — ● Change synthetic lubricant while crankcase is warm. ● Replace filter element.

* indicates months/operating hours, whichever occurs first.

FILTER INSPECTION & CLEANING

1. Unscrew and remove the wing nut (A) securing the filter housing (B) to its base (C).
2. Remove the filter housing and withdraw the old filter element (D). Clean the element with a jet of air or vacuum.
3. Replace the filter element and housing, securing it in place with the wing nut previously removed.

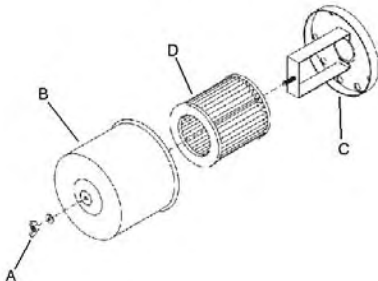

OIL CHANGE

1. Remove the oil drain plug (A) and allow the lubricant to drain into a suitable container.
2. Replace the oil drain plug.
3. Follow the filling procedures in OPERATION section.

BELT ADJUSTMENT

CHECKING BELT TENSION. Check belt tension should be occasionally, especially if looseness is suspected. New belts must also be properly tensioned upon installation.

TENSIONING BELTS. Belt tensioning can be achieved by loosening the motor or engine anchor screws, pushing the motor or engine away from the pump, and retightening the motor or engine anchor screws. Some units are equipped with a belt tensioning bolt that, when turned, pulls the motor or engine away from the pump. Otherwise, the motor can be easily moved by placing a prying tool beneath it. A commercially available spreader or other belt tensioning device can also be helpful.

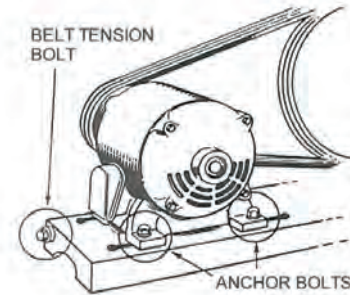

Follow the procedures outlined below to correctly set and measure belt tension on electric motor and gas engine models including 2340, 2475, and 2545 (with "A" belt type only). Refer to the following illustration for a visual representation.

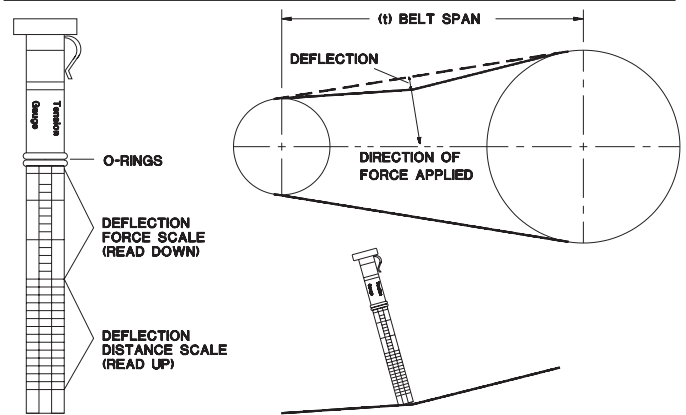

1. Lay a straight edge across the top outer surface of the belt drive from pulley to sheave.
2. At the center of the span, perpendicular to the belt, apply pressure to the outer surface of the belt with a tension gauge. Force the belt to the deflection indicated in the BELT TENSION TABLE in the DIAGRAMS & TABLES section. Compare the reading on the tension gauge to the table.

Follow the procedures outlined below to correctly set and measure tension on 7.5 through 30 horsepower models 2545, 7100, 15T and 3000 with "B" and "C" belt types.

1. Measure the span length (t) of the drive.
2. Determine the amount of deflection (in inches) required to measure deflection force (in pounds) by multiplying the span length (t) by 1/64. For example, a 32" span length multiplied by 1/64 equals 1/2" of deflection required to measure deflection force.
3. Lay a straight edge across the top outer surface of the belt drive from pulley to sheave.
4. At the center of the span, perpendicular to the belt, apply pressure to the outer surface of the belt with a tension gauge. Force the belt to the predetermined deflection calculated in step 2. Compare the reading on the tension gauge to the BELT TENSION TABLE in the DIAGRAMS & TABLES section.

Ensure the pulley and sheave are properly aligned and the motor anchor screws are adequately retightened prior to restarting the compressor.

⚠ CAUTION Improper pulley/sheave alignment and belt tension can result in motor overload, excessive vibration, and premature belt and/or bearing failure.

To prevent these problems from occurring, ensure the pulley and sheave are aligned and belt tension is satisfactory after installing new belts or tensioning existing belts.

ELECTRIC DRAIN MAINTENANCE

NOTE The following maintenance schedule has been developed for typical applications. Maintenance intervals should be shortened in harsher environments.

DRAIN VALVE MAINTENANCE SCHEDULE	
DAILY	Test the valve for proper operation. Clean the filter screen if needed.
MONTHLY (EVERY 30 DAYS)	Clean the filter screen.

To clean the filter screen, perform the following steps:

1. Close the strainer ball valve completely to isolate it from the air receiver tank.
 2. Press the TEST button on the timer to vent the pressure remaining in the valve. Repeat until all pressure is removed.
- ⚠ CAUTION** High pressure air can cause injury from flying debris. Ensure the strainer ball valve is completely closed and pressure is released from the valve prior to cleaning.
3. Remove the plug from the strainer with a suitable wrench. If you hear air escaping from the cleaning port, STOP IMMEDIATELY and repeat steps 1 and 2.
 4. Remove the stainless steel filter screen and clean it. Remove any debris that may be in the strainer body before replacing the filter screen.

5. Replace plug and tighten with wrench.

Position of weight and thrust pin when unit is operating.

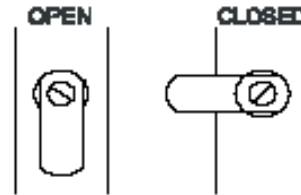

6. When putting the EDV-2000 back into service, press the TEST button to confirm proper function.

TANK INSPECTION

The life of an air receiver tank is dependent upon several factors including, but not limited to, operating conditions, ambient environments, and the level of maintenance. The exact effect of these factors on tank life is difficult to predict; therefore, Ingersoll-Rand recommends that you schedule a certified tank inspection within the first five years of compressor service. To arrange a tank inspection, contact Ingersoll-Rand.

If the tank has not been inspected within the first 10 years of compressor service, the receiver must be taken out of service until it has passed inspection. Tanks that fail to meet requirements must be replaced.

⚠ WARNING Failure to replace a rusted air receiver tank could result in air receiver tank rupture or explosion, which could cause substantial property damage, severe personal injury, or death. Never modify or repair tank. Obtain replacement from service center.

TROUBLESHOOTING

PROBLEM	CHECK POINT
Abnormal piston, ring or cylinder wear	4, 8, 9, 19, 28, 35
Air delivery drops off	1, 6, 15, 16, 18, 19, 29
Automatic drain valve leaks or does not drain automatically	16
Auxiliary valve chatters or leaks around stem	23, 24
Broken intercooler or aftercooler tubes	36
Compressor does not come up to speed	2, 6, 12, 15, 21
Compressor is slow to come up to speed	26, 27, 33, 34
Compressor runs excessively hot	3, 14, 15, 22
Compressor will not unload cycle	23, 24, 26
Compressor will not unload when stopped	26, 33
Excessive noise during operation	2, 6, 15, 16, 21, 27, 32
Excessive starting and stopping	5, 11, 16, 32, 40
Knocks or rattles	2, 15, 17, 19, 20, 21
Lights flicker or dim when running	12, 13
Moisture in crankcase or "milky" appearance in petroleum lubricant or rusting in cylinders	9, 10
Motor overload trips or draws excessive current	5, 6, 12, 13, 14, 15, 16, 19, 20, 21, 34
Oil in discharge air (oil pumping)	4, 7, 9, 18, 19, 25, 35
Oil leaking from shaft seal	25
Safety/relief valve "pops"	1, 5, 29, 30
High interstage pressure	30
Low interstage pressure	31
Engine cranks slowly or will not start	6, 14, 37, 38
Motor will not start	12
Engine will not start	39
Oil Leaks	41

ELECTRIC DRAIN TROUBLESHOOTING

Trouble	Cause	Action
Valve will not close.	<ol style="list-style-type: none"> 1. Debris in solenoid valve prevents diaphragm from seating. 2. Short in electrical component. 	<ol style="list-style-type: none"> 1. Remove solenoid valve, disassemble, clean and reassemble. 2. Check and replace power cord or timer as needed.
Timer will not activate.	<ol style="list-style-type: none"> 1. No electrical supply. 2. Timer malfunction 3. Clogged port. 4. Solenoid valve malfunction. 5. Clogged strainer. 	<ol style="list-style-type: none"> 1. Apply power. 2. Replace timer. 3. Clean valve. 4. Replace solenoid valve. 5. Clean strainer.

CHECK POINT	POSSIBLE CAUSE	POSSIBLE SOLUTION
1	Clogged or dirty inlet and/or discharge line filter.	Clean or replace.
2	Loose beltwheel or motor pulley, excessive end play in motor shaft or loose drive belts.	Check beltwheel, motor pulley, crankshaft, drive belt tension and alignment. Repair or replace as required.
3	Inadequate ventilation around beltwheel.	Relocate compressor for better air flow.
4	Lubricant viscosity too low.	Drain existing lubricant and refill with proper lubricant.
5	Air leaks in air discharge piping.	Check tubing and connections. Tighten joints or replace as required.
6	Lubricant viscosity too high.	Drain existing lubricant and refill with proper lubricant.
7	Lubricant level too high.	Drain excess lubricant.
8	Lubricant level too low.	Add lubricant to crankcase to proper level.
9	Detergent type lubricant being used.	Drain existing lubricant and refill with proper lubricant.
10	Extremely light duty cycles. Compressor located in damp or humid location.	Run compressor for longer duty cycles. Relocate compressor or install crankcase heater kit.
11	Pressure switch differential too narrow.	Adjust pressure switch to increase differential, if differential adjustment is provided. Install pressure switch with differential adjustment feature if differential adjustment is desired.
12	Improper line voltage. Wiring or electric service panel too small. Poor contact on motor terminals or starter connections. Improper starter overload heaters.	Check line voltage and upgrade lines as required. Contact electrician. Install properly sized wire or service box. Contact electrician. Ensure good contact on motor terminals or starter connections. Install proper starter overload heaters. Contact electrician.
13	Poor power regulation (unbalanced line).	Contact power company.
14	Drive belts too tight or misaligned.	Adjust belts to proper tension and alignment.
15	Compressor valves leaky, broken, carbonized or loose.	Inspect valves. Clean or replace as required. Install Valve/Gasket Step Saver Kit..
16	Automatic drain valve clogged, leaking or defective.	Inspect valve and clean, repair or replace as required.
17	Carbon build-up on top of piston(s).	Clean piston(s). Repair or replace as required.
18	Piston rings damaged or worn (broken, rough or scratched). Excessive end gap or side clearance. Piston rings not seated, are stuck in grooves or end gaps not staggered.	Install Ring/Gasket Step Saver Kit. Adjust piston rings.
19	Cylinder(s) or piston(s) scratched, worn or scored.	Repair or replace as required.
20	Connecting rod, piston pin or crankpin bearings worn or scored. Loose bearing spacer on crankshaft.	Inspect all. Repair or replace as required. Install Bearing/Connecting Rod Step Saver Kit.
21	Defective ball bearings on crankshaft or motor shaft.	Inspect bearings and replace if required. Install Bearing/Connecting Rod Step Saver Kit.
22	Wrong beltwheel direction of rotation.	Check motor wiring for proper connections. Reverse two leads on three-phase motors.
23	Leaking, broken or worn inlet unloader parts.	Inspect parts and replace as required.
24	Auxiliary valve dirty or seats worn.	Inspect parts. Clean, adjust or replace as required.
25	Crankshaft seal worn or crankshaft scored.	Replace seal. Install shaft sleeve if required. Install Bearing/Connecting Rod Step Saver Kit.
26	Leaking or maladjusted centrifugal pilot valve.	Replace pilot valve o-ring. Adjust pilot valve.
27	Leaking check valve or check valve seat blown out.	Replace check valve.
28	Extremely dusty atmosphere.	Install remote air inlet piping and route to source of cleaner air. Install more effective filtration.
29	Defective safety/relief valve.	Replace.
30	High pressure inlet valve leaking.	Inspect, clean or repair as required.
31	Low pressure discharge valve leaking.	Inspect, clean or repair as required.
32	Automatic start and stop mode is not suitable for air demand.	Adjust auxiliary valve for constant speed operation.
33	Pressure switch unloader leaks or does not work.	Realign stem or replace.
34	Ambient temperature too low.	Install crankcase heater kit. Convert to All Season Select lubricant. Relocate compressor to warmer environment.
35	Worn cylinder finish.	Deglaze cylinder with 180 grit flex-hone.
36	Beltwheel out of balance, tubes not braced or secured, wrong pulley speed.	Check vibration level, change pulley or beltwheel if required, tighten tube clamps.
37	Engine not grounded properly.	Ground battery to engine as recommended.
38	Gasoline exceeds storage time or contains water.	Replace gas, add fuel stabilizer.
39	No fuel in tank. Fuel valve closed. Low oil pressure.	See manufacturer's instructions for refueling. Open fuel valve. See manufacturer's instructions.
40	Excessive condensate in receiver tank.	Drain receiver tank with manual drain valve or install automatic drain valve.
41	Loose fittings/elbows/connectors	Re-torque fittings per specified torque requirements

DIAGRAMS & TABLES

FASTENER TORQUE TABLE

	2340	2475	2545	7100	15T	3000
High Pressure Head Bolts	75	75	75	75	75	75
Low Pressure Head Bolts	75	75	75	75	75	75
Cylinder Flange Bolts	30	50	50	50	50	50
Frame Cover Bolts	17	17	17	20	20	20
Shaft Cover Bolts	17	17	17	20	20	20
Crankpin Cap Screws	5.5	11	11	12-15	12-15	12-15
Unloader Cover Screws	—	—	11	11	20	11
High Pressure Inlet Valve Screws	11-15 LB-IN	11-15 LB-IN	11-15 LB-IN	5.5	—	5.5
Low Pressure Inlet Valve Screws	11-15 LB-IN	25-30 LB-IN	25-30 LB-IN	5.5	—	5.5
High Pressure Outlet Valve Screws	11-15 LB-IN	11-15 LB-IN	11-15 LB-IN	26	50	26
Low Pressure Outlet Valve Screws	25-30 LB-IN	25-30 LB-IN	25-30 LB-IN	26	90	26
Beltwheel Bolt	33	60	60	113	213	213
High Pressure Head Center Bolts	—	—	10	—	—	—
Low Pressure Head Center Bolts	—	—	14-16	—	—	—

NOTE Tighten all fasteners evenly using a cross pattern in two stages.

BELT TENSION TABLE

MODEL	DEFLECTION (IN.)	TENSION (LB.)	BELT TYPE	HORSEPOWER	TENSION AT 1/64" DEFLECTION PER INCH OF SPAN
2340 (14" Span)	0.25	4.9 - 7.1			
2340 (19" Span)	0.29	4.9 - 7.1	B	7.5	7.0 - 10.0
2475 (14" Span)	0.25	4.9 - 7.1		10-15	8.0 - 12.0
2475 (19" Span)	0.29	4.9 - 7.1	C	20	12.0 - 18.0
2475F/X11GH	0.34	5.5 - 8.0		25-30	14.0 - 21.0
2475F/X9/11GK	0.25	11.25 - 13.0			
2475N5 (14.5" Span, Cogged belt)	0.23	4.5 - 6.5			
2545 (A Groove)	0.29	4.9 - 7.1			

ELECTRICAL WIRING DIAGRAMS

Single Phase Wiring

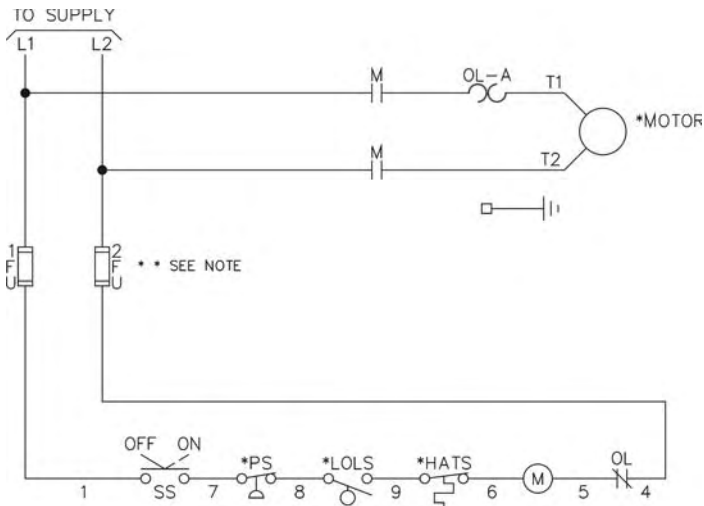

A	To supply
C	Wiring for optional electric drain valve
EDV	Electric drain valve
T	Supply Line Terminal
L	Load Terminal
FU	Control Circuit Fuse
HATS	High Air Temperature Switch (#)
LOLS	Low Oil Level Switch (#)
M	Motor Starter Coil
OL	Motor Starter Overload
PS	Pressure Switch
SS	Selector Switch (#)
*	Alternate wiring for converting 3 phase starter to 1 phase application
(#)	= if provided

Three Phase Wiring

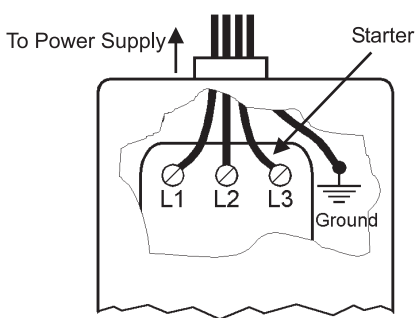
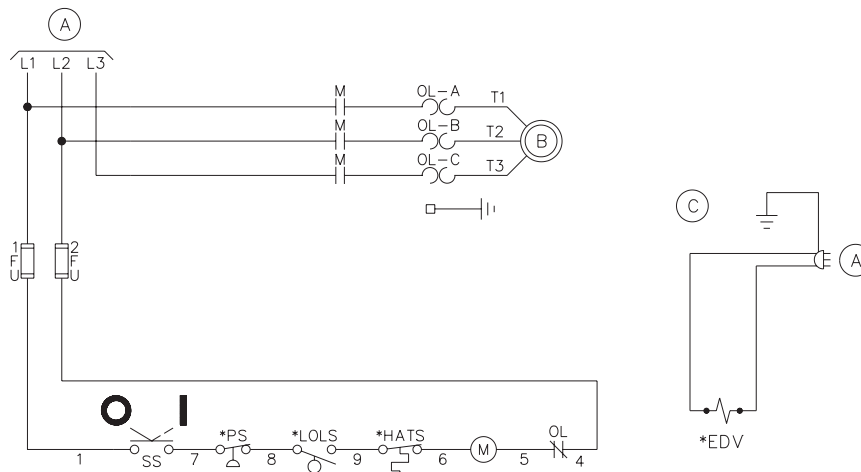

NOTE

On units requiring a starter, connect line power to the starter. do not connect line power to the pressure switch.

- Connect ground wire to ground lug
- L3 used for 3-phase motors & starters only

Typical Baseplate Unit

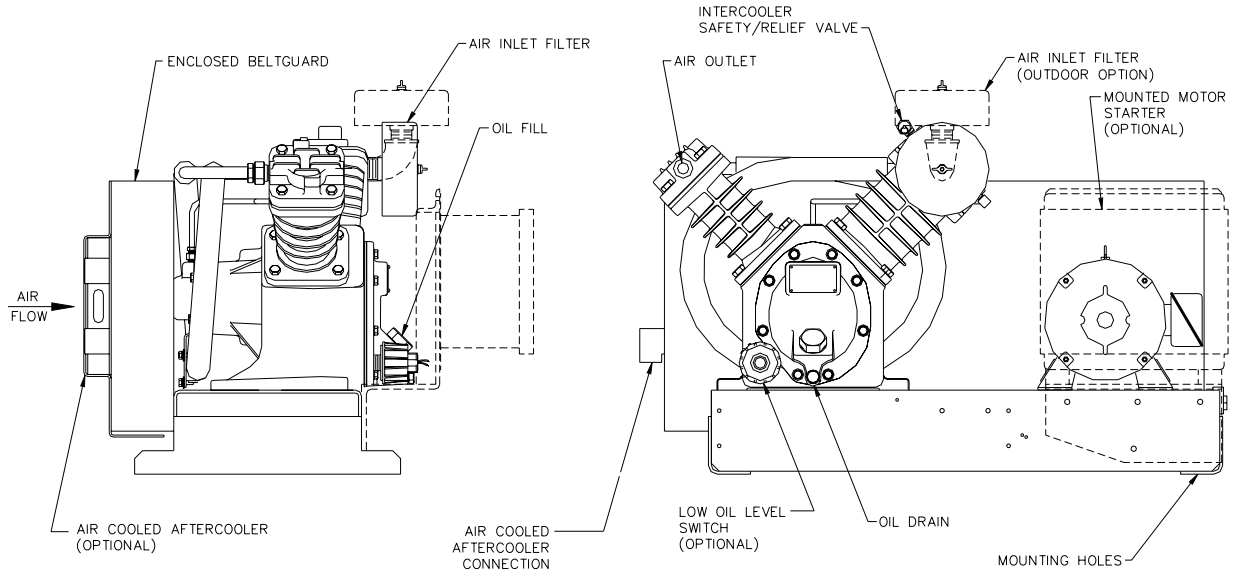

Typical Horizontal Simplex Unit

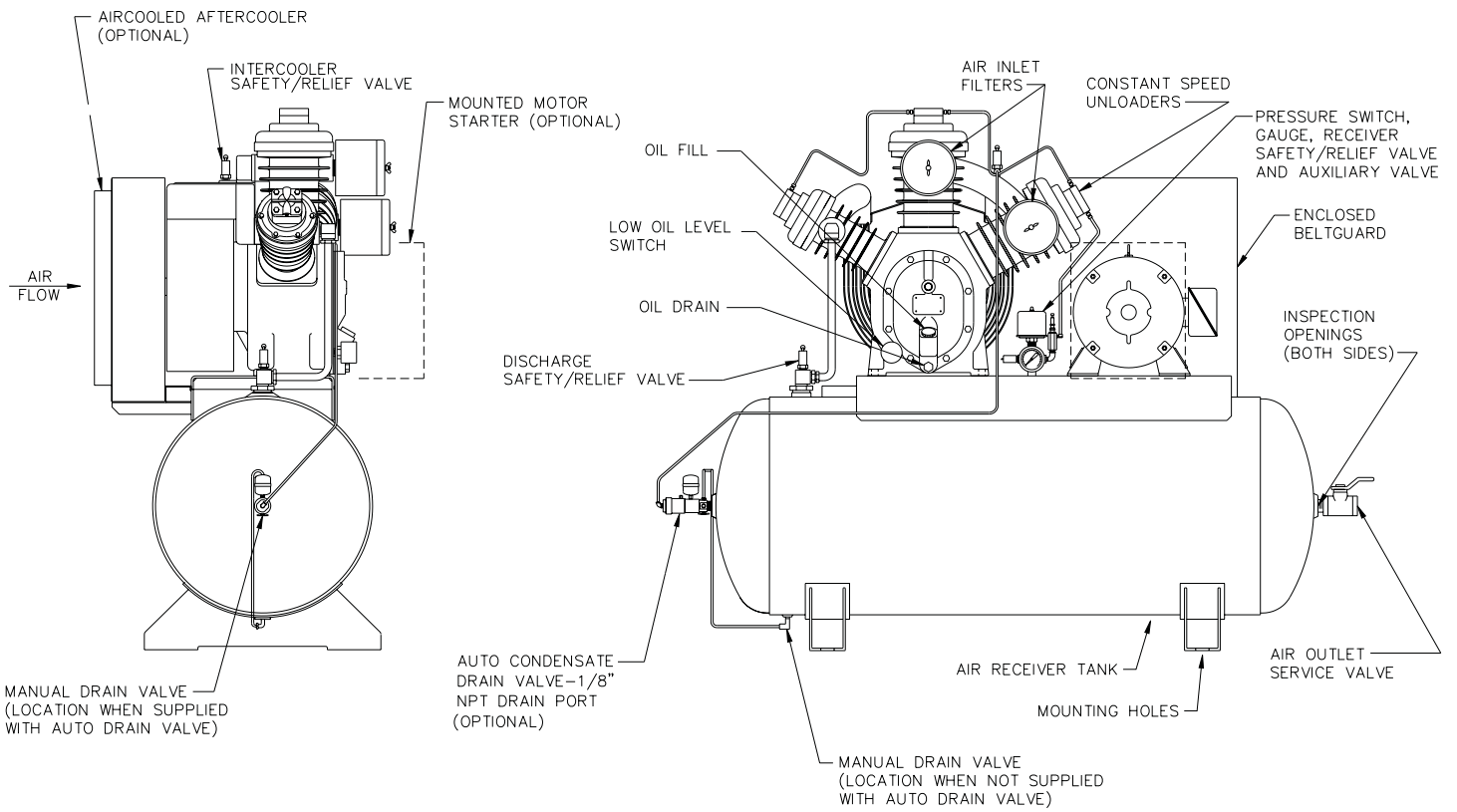

Typical Vertical Simplex Unit

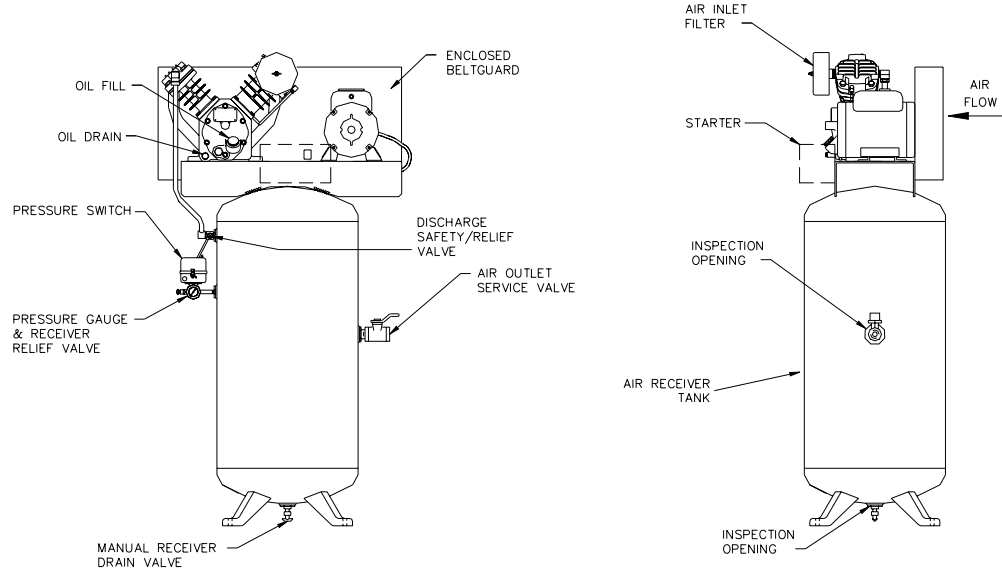

Typical Gasoline Engine Unit

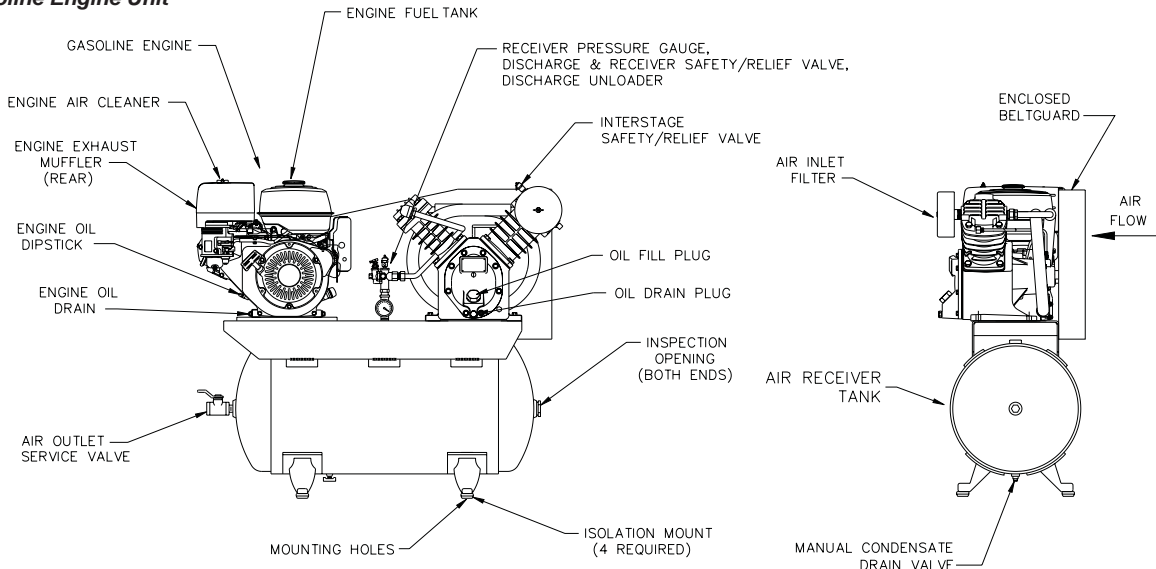

Typical Duplex Unit

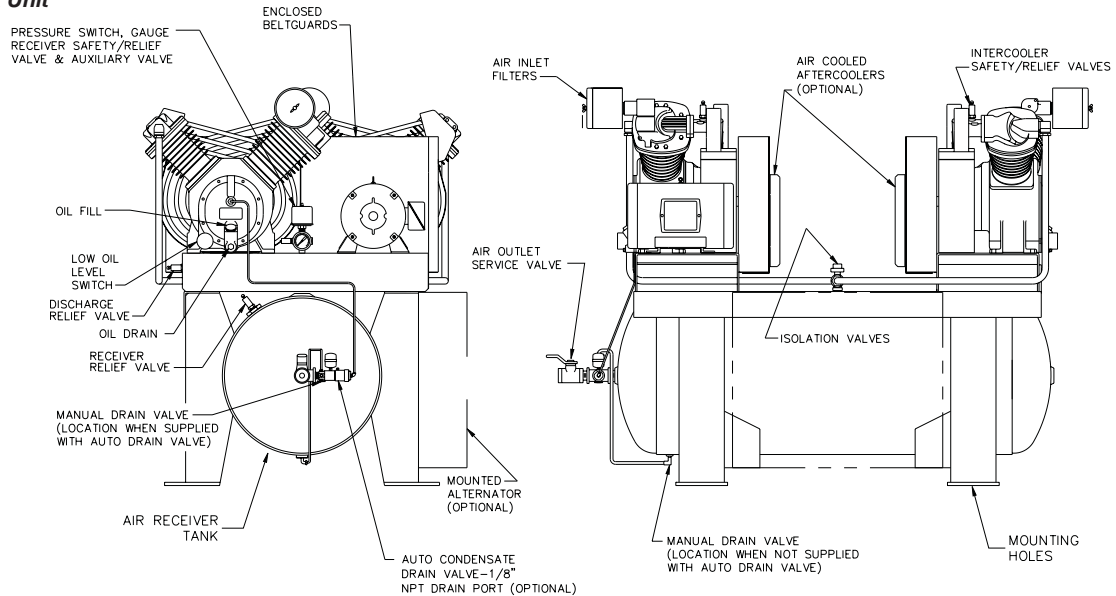

WARRANTY

Ingersoll-Rand Company warrants that the Equipment manufactured by it and delivered hereunder shall be free of defects in material and workmanship for a period of twelve (12) months from the date of placing the Equipment in operation or eighteen (18) months from the date of shipment, whichever shall occur first. The foregoing warranty period shall apply to all Equipment, except for the following: (A) Compressors that are operated solely on All Season Select synthetic compressor lubricant will have their bare compressor warranted for the earlier of twenty-four (24) months from the date of initial operation or thirty (30) months from the date of shipment. (B) Replacement parts will be warranted for six (6) months from the date of shipment. Should any failure to conform to this Warranty be reported in writing to the Company within said period, the Company shall, at its option, correct such nonconformity by suitable repair to such Equipment, or furnish a replacement part F.O.B. point of shipment, provided the purchaser has installed, maintained and operated such equipment in accordance with good industry practices and has complied with specific recommendations of the Company. Accessories or equipment furnished by the Company, but manufactured by others, shall carry whatever warranty the manufacturer conveyed to Ingersoll-Rand Company and which can be passed on to the Purchaser. The Company shall not be liable for any repairs, replacements, or adjustments to the Equipment or any costs of labor performed by the Purchaser without the Company's prior written approval.

The Company makes no performance warranty unless specifically stated within its proposal and the effects of corrosion, erosion and normal wear and tear are specifically excluded from the Company's Warranty. In the event performance warranties are expressly included, the Company's obligation shall be to correct in the manner and for the period of time provided above.

THE COMPANY MAKES NO OTHER WARRANTY OF REPRESENTATION OF ANY KIND WHATSOEVER, EXPRESSED OR IMPLIED, EXCEPT THAT OF TITLE, AND ALL IMPLIED WARRANTIES OF MERCHANTABILITY AND FITNESS FOR A PARTICULAR PURPOSE, ARE HEREBY DISCLAIMED.

Correction by the Company of nonconformities, whether patent or latent, in the manner and for the period of time provided above, shall constitute fulfillment of all liabilities of the Company and its Distributors for such nonconformities with respect to or arising out of such Equipment.

LIMITATION OF LIABILITY

THE REMEDIES OF THE PURCHASER SET FORTH HEREIN ARE EXCLUSIVE, AND THE TOTAL LIABILITY OF THE COMPANY, ITS DISTRIBUTORS AND SUPPLIERS WITH RESPECT TO CONTRACT OR THE EQUIPMENT AND SERVICES FURNISHED, IN CONNECTION WITH THE PERFORMANCE OR BREACH THEREOF, OR FROM THE MANUFACTURE, SALE, DELIVERY, INSTALLATION, REPAIR OR TECHNICAL DIRECTION COVERED BY OR FURNISHED UNDER CONTRACT, WHETHER BASED ON CONTRACT, WARRANTY, NEGLIGENCE, INDEMNITY, STRICT LIABILITY OR OTHERWISE SHALL NOT EXCEED THE PURCHASE PRICE OF THE UNIT OF EQUIPMENT UPON WHICH SUCH LIABILITY IS BASED.

THE COMPANY, ITS DISTRIBUTORS AND ITS SUPPLIERS SHALL IN NO EVENT BE LIABLE TO THE PURCHASER, ANY SUCCESSORS IN INTEREST OR ANY BENEFICIARY OR ASSIGNEE OF THE CONTRACT FOR ANY CONSEQUENTIAL, INCIDENTAL, INDIRECT, SPECIAL OR PUNITIVE DAMAGES ARISING OUT OF THIS CONTRACT OR ANY BREACH THEREOF, OR ANY DEFECT IN, OR FAILURE OF, OR MALFUNCTION OF THE EQUIPMENT, WHETHER OR NOT BASED UPON LOSS OF USE, LOSS PROFITS OR REVENUE, INTEREST, LOST GOODWILL, WORK STOPPAGE, IMPAIRMENT OF OTHER GOODS, LOSS BY REASON OF SHUTDOWN OR NON-OPERATION, INCREASED EXPENSES OF OPERATION, COST OF PURCHASE OF REPLACEMENT POWER, OR CLAIMS OF PURCHASER OR CUSTOMERS OF PURCHASER FOR SERVICE INTERRUPTION WHETHER OR NOT SUCH LOSS OR DAMAGE IS BASED ON CONTRACT, WARRANTY, NEGLIGENCE, INDEMNITY, STRICT LIABILITY OR OTHERWISE.

