

TRADE SECRET –CONFIDENTIAL AND PROPRIETARY
 EXCLUSIVELY OWNED BY LAPLANTE COMPRESSOR, LTD.,
 ANY COPYING, USE OR DISCLOSURE WITHOUT THE WRITTEN
 PERMISSION OF LAPLANTE COMPRESSOR, LTD. IS STRICTLY
 PROHIBITED. THIS MATERIAL IS PROTECTED UNDER
 TRADE SECRET AND UNFAIR COMPETITION LAWS. THE
 EXPRESSION OF THE INFORMATION IS PROTECTED UNDER
 FEDERAL COPYRIGHT LAWS. VIOLATIONS MAY RESULT IN
 CIVIL AND CRIMINAL FINES AND PENALTIES.

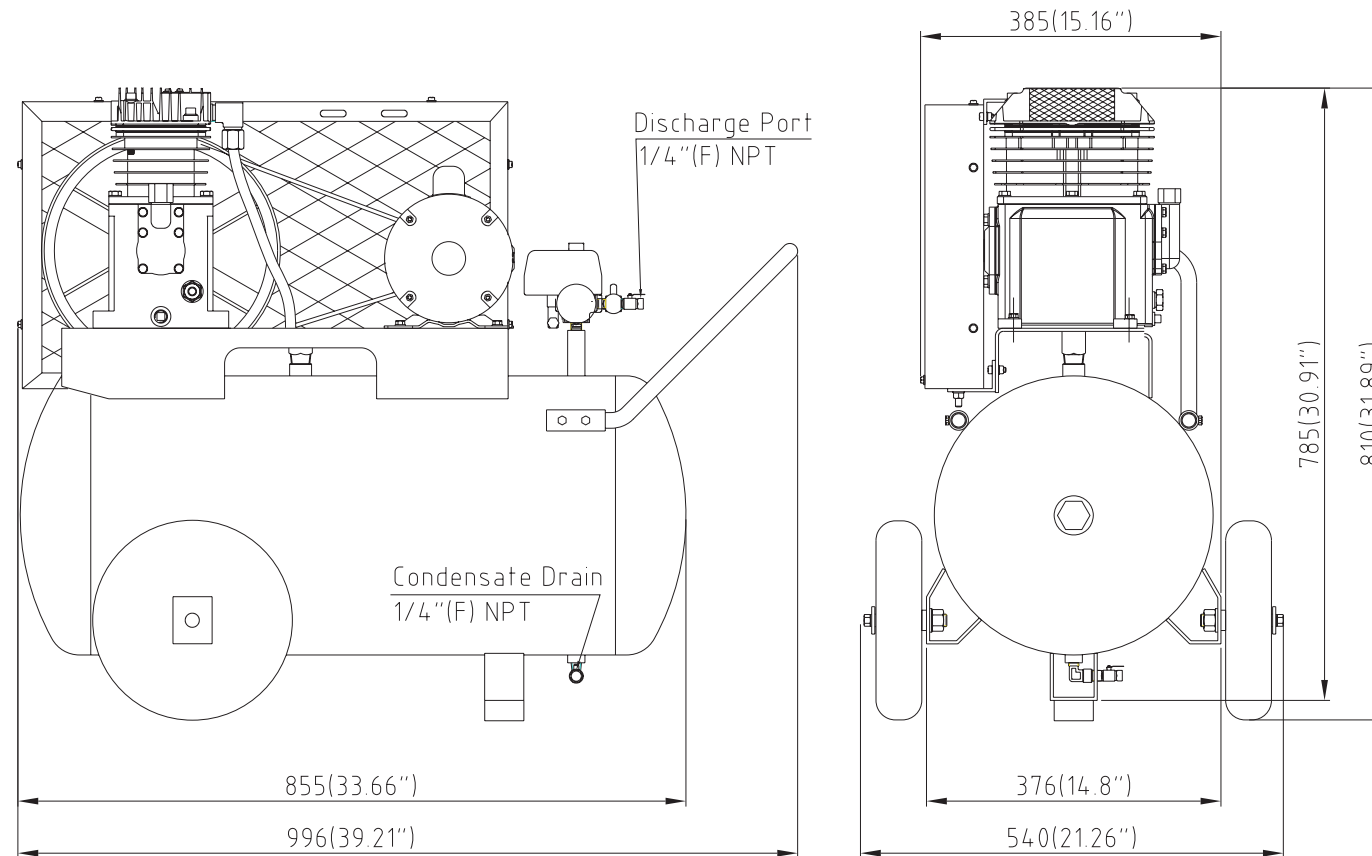

Specification:

Pump:

- Type: LPSS7550
- Cylinders: 2
- Bore : 2.95"/75mm
- Stroke: 1.97"/50mm
- RPM: 1026
- Pump Flywheel: 12"/305mm/1A

Motor:

- Power: 3HP/2.24Kw
- Voltage: 208-230V
- Phase: 1PH
- Frequency: 60Hz
- Amps: 15 A
- RPM: 3450RPM
- Motor Pulley:

Tank:

- 20Gal/76Ltr
- Max. Pressure: 175Psi

Pressure Switch:

- Pressure Range: 125~155Psi

Rating CFM @ 125Psi: 11.71
 @ 145Psi: 11.51
 @ 155Psi: 11.32

Rating ACFM @ 125Psi: 11.36
 @ 145Psi: 11.16
 @ 155Psi: 10.98

Standard Package:

- Single : 1 Pcs,Weight: XXXLB/XXXKg
- Crate : xxx Pcs,Weight: xxxLB/xxxxKg
- 20' Container : xxx Pcs
- 40' Container : xxx Pcs

	Address:7502 Mesa Road Houston, TX77028
	Telephone: (713) 635-6291 E-mail: sales@Lapante.com Web Site: www.Laplantecompressor.com

TITLE

C20215-7550 Specification