

TRADE SECRET –CONFIDENTIAL AND PROPRIETARY  
 EXCLUSIVELY OWNED BY LAPLANTE COMPRESSOR, LTD.,  
 ANY COPYING, USE OR DISCLOSURE WITHOUT THE WRITTEN  
 PERMISSION OF LAPLANTE COMPRESSOR, LTD. IS STRICTLY  
 PROHIBITED. THIS MATERIAL IS PROTECTED UNDER  
 TRADE SECRET AND UNFAIR COMPETITION LAWS. THE  
 EXPRESSION OF THE INFORMATION IS PROTECTED UNDER  
 FEDERAL COPYRIGHT LAWS. VIOLATIONS MAY RESULT IN  
 CIVIL AND CRIMINAL FINES AND PENALTIES.

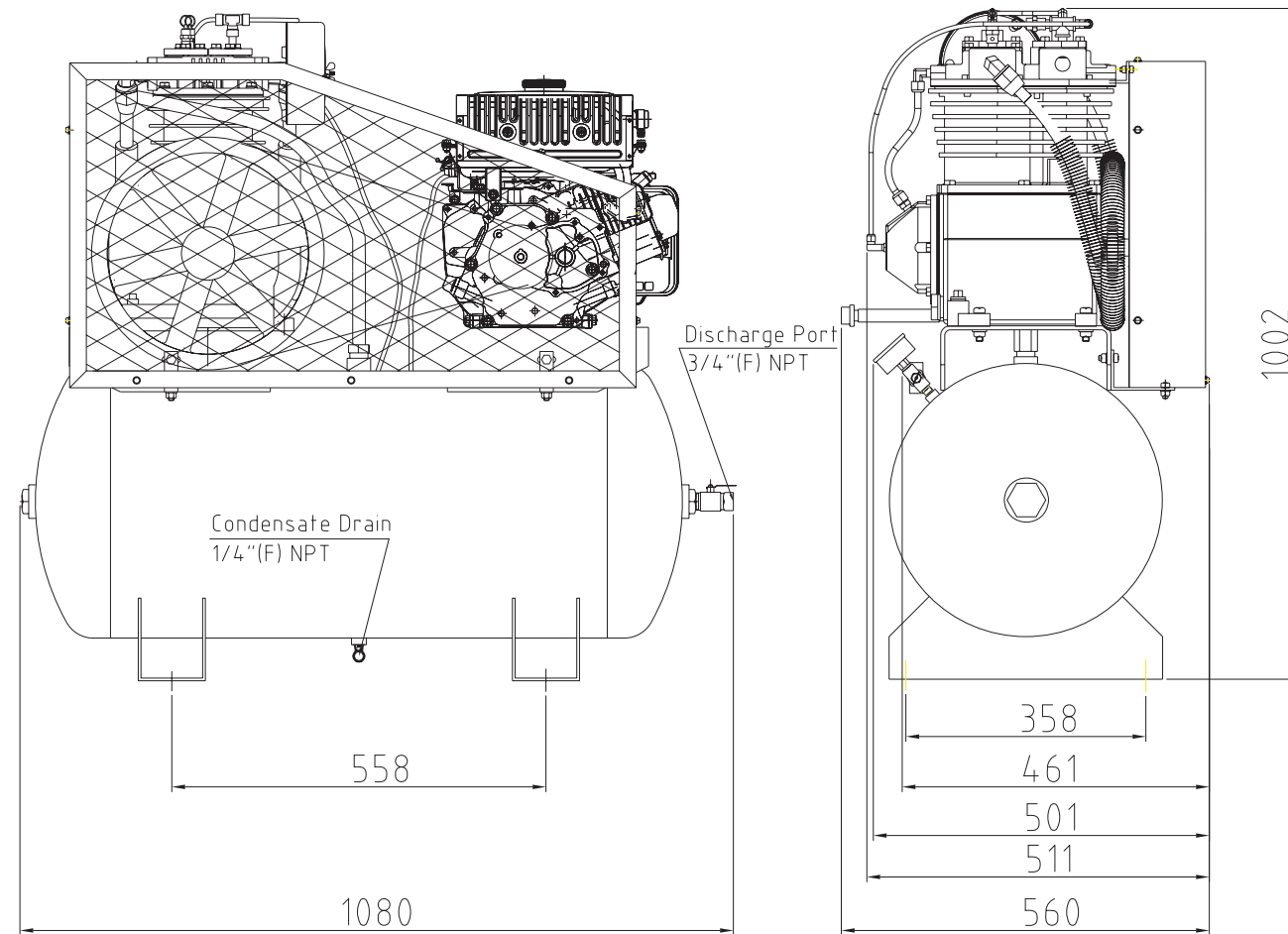

## Specification:

### Pump:

- Type: LP335SK
- Cylinders: 2
- Bore of LP : 4.75"/121mm
- Bore of HP : 2.5"/63.5mm
- Stroke: 3"/76mm
- RPM: 908
- Pump Flywheel: 13.75"/349.25mm/2B

### Engine:

- Power: 12HP/8.95Kw
- Electric Control
- RPM: 3600
- Engine Pulley:

### Tank:

- 30Gal/113.6Ltr
- Max. Pressure: 200Psi

### Combination Valve:

- Combination Valve Control

Rating CFM @ 125Psi: 21.95  
 @ 155Psi: 21.71  
 @ 175Psi: 22.24

Rating ACFM @ 125Psi: 21.29  
 @ 155Psi: 21.06  
 @ 175Psi: 20.57

### Standard Package:

- Single : 1 Pcs, Weight: XXXLB/XXXKg
- Crate : xxx Pcs, Weight: xxxLB/xxxxKg
- 20' Container : xxx Pcs
- 40' Container : xxx Pcs



Address: 7502 Mesa Road Houston, TX 77028  
 Telephone: (713) 635-6291  
 E-mail: sales@Lapante.com  
 Web Site: www.Lapantecompressor.com

TITLE

HD30GY12E-335SK Specification