

Drawings, Dimensions, and Specifications

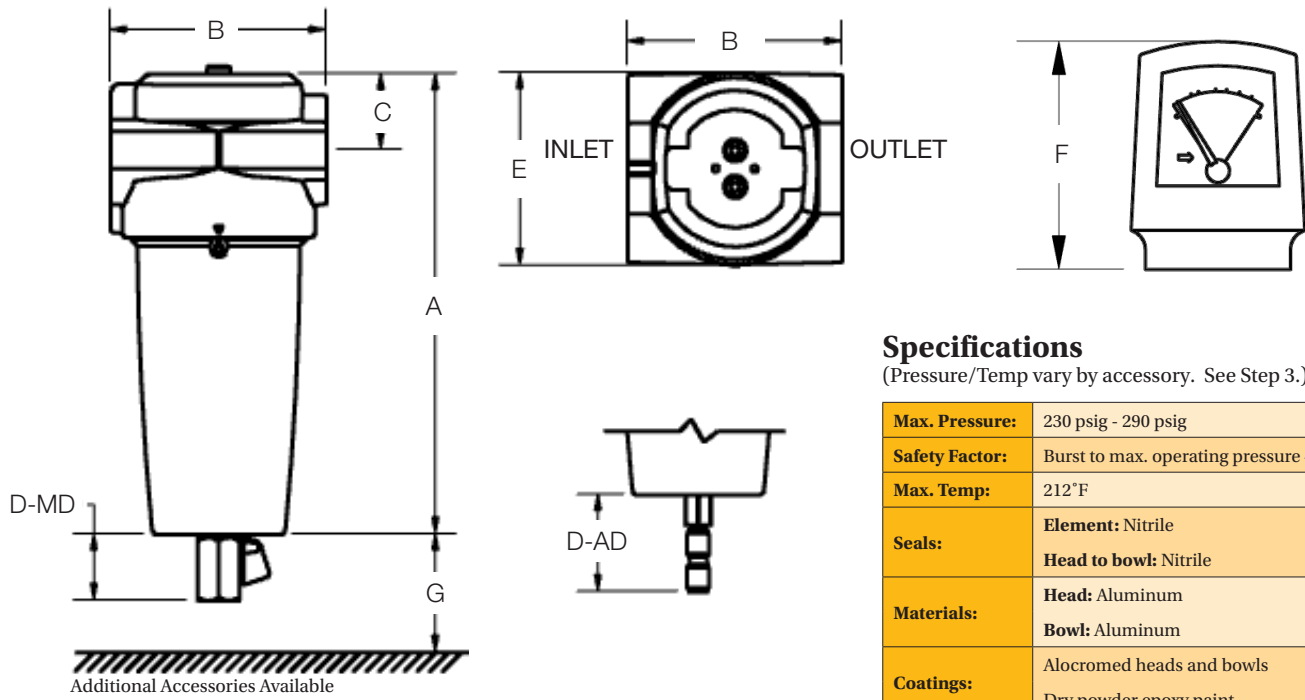

Specifications

(Pressure/Temp vary by accessory. See Step 3.)

Max. Pressure:	230 psig - 290 psig
Safety Factor:	Burst to max. operating pressure 4:1
Max. Temp:	212°F
Seals:	Element: Nitrile Head to bowl: Nitrile
Materials:	Head: Aluminum Bowl: Aluminum
Coatings:	Alocromed heads and bowls Dry powder epoxy paint

Weights and Dimensions

Model No.	Conn. (NPT)	A (in.)	B (in.)	C (in.)	D-MD (in.)	D-AD (in.)	E (in.)	F (in.)	G (in.)	Sump (oz.)	Wt. (lbs.)
HXN1A-	1/4"	7.0	2.6	0.9	1.6	2.4	2.6	N/A	1.2	2.7	1.4
HXN15B-	3/8"	9.4	3.5	1.5	1.6	2.4	3.4	2.7	1.9	7.4	3.1
HXN2B-	1/2"	9.4	3.5	1.5	1.6	2.4	3.4	2.7	1.9	7.4	3.1
HXN2BH-	1/2"	9.4	3.5	1.5	1.6	2.4	3.4	2.7	1.9	4.4	3.1
HXN3BH-	3/4"	9.4	3.5	1.5	1.6	2.4	3.4	2.7	1.9	4.4	3.1
HXN3C-	3/4"	10.9	5.1	1.8	1.6	2.3	4.6	2.7	2.6	8.6	6.3
HXN4C-	1"	10.9	5.1	1.8	1.6	2.3	4.6	2.7	2.6	8.6	6.3
HXN4D-	1"	14.5	5.1	1.8	1.6	2.3	4.6	2.7	2.6	7.4	7.2
HXN5D-	1-1/4"	14.5	5.1	1.8	1.6	2.3	4.6	2.7	2.6	7.4	7.2
HXN6D-	1-1/2"	14.5	5.1	1.8	1.6	2.3	4.6	2.7	2.6	7.4	7.2
HXN5E-	1-1/4"	17.3	6.5	2.2	1.6	2.4	6.2	2.7	3.9	12.8	9.5
HXN6E-	1-1/2"	17.3	6.5	2.2	1.6	2.4	6.2	2.7	3.9	12.8	9.5
HXN8E-	2"	17.3	6.5	2.2	1.6	2.4	6.2	2.7	3.9	12.8	9.5
HXN8F-	2"	20.9	6.5	2.2	1.6	2.4	6.2	2.7	3.9	12.3	15.9
HXN8G-	2"	27.7	6.5	2.2	1.6	2.4	6.2	2.7	3.9	11.1	19.9
HXN10H-	2-1/2"	25.7	7.6	2.8	1.7	2.4	7.2	2.7	4.7	22.0	26.9
HXN12H-	3"	25.7	7.6	2.8	1.7	2.4	7.2	2.7	4.7	22.0	26.9
HXN12J-	3"	33.2	7.6	2.8	1.7	2.4	7.2	2.7	4.7	22.0	31.0