

# OPERATION MANUAL

## WATER SEPARATOR

### Series AMG

To get the best performance from your purchase, be sure to read this manual carefully before use.

Refer drawings or catalogue for construction and specifications.

Please understand the contents of this operation manual may be revised without notification.

#### FEATURES

- Water drop contained in compressed air is effectively removed just by installing this.
- You hardly need to replace the element of this product due to unique structure.

#### CAUTIONS ON USE

Keep following items to operate water separator properly.

Do not use under following environment.

Chemicals      Corrosive gas + Atmosphere containing organic solvent

Environment lower than 5

Environment Higher than 60

Vibration, impact

**WARNING**

Following environments lead to cause breakage. Broken pieces injuring if broken.

-1-

Do not use under following conditions.

Fluid except compressed air

Air pressure more than 1.0MPa\*\* and 0.05MPa\* or less

Air only!

Min. 0.05MPa  
Max. 1.0 MPa

\*Type N.C. auto drain: 0.15MPa,  
Type N.O. auto drain: 0.1MPa

\*\*Option H: 1.6 MPa

**WARNING**

Following conditions lead to cause breakage.

Place where more than 0.1MPa pressure pulsation

Place where air may flow backwards

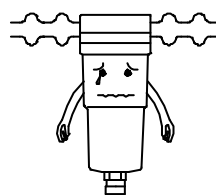

Over rated flow

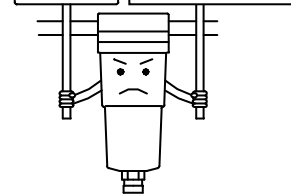
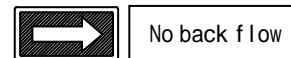

**WARNING**

Following conditions cause element breakage.

Precautions for installation.

- Install vertically.
- Ensure no leakage.
- Flush inside of pipings with air.
- Do not pipe upwardly.
- Keep sight glass in front.
- Drain while liquid level is visible.
- Drain piping: 5m or less
- N.C. auto drain: 4 or more (I.D.), 10 (O.D.)
- N.O. auto drain: 6.5 or more (I.D.), 10 (O.D.)
- AMG850: 9 or more (I.D.), 2.8 m or less (overall length)
- Install it in where pressure is higher and temperature is lower.

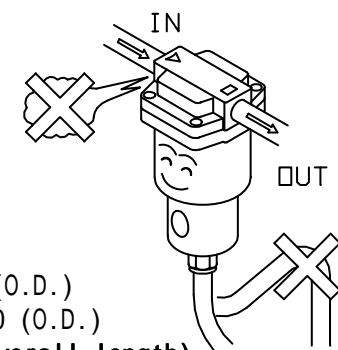

-2-

#### Application and line arrangement of water separator

##### 1. General applications and arrangement

Please refer to the applications and arrangement

which are used normally as Figure 1.

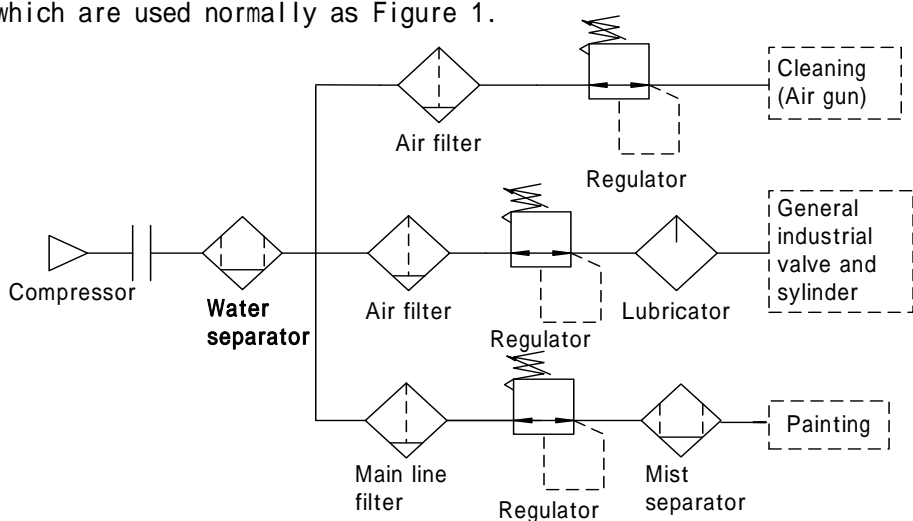

Figure 1 . Application and circuit

##### 2. How to use water separator

###### 1) To maximize the performance of the water separator

Liquidize the moisture (vapor) in the air as much as possible and lower air pressure and relative humidity after removing the liquidized moisture. To make the condition mentioned above, when the water separator is mounted, keep following points.

Mount the water separator to the place with the highest pressure in used pneumatic circuit. (High pressure helps liquidize the moisture.) Mount the regulator to the outlet side of the water separator(just after secondary side).

Mount the water separator to the place with lowest temperature in used pneumatic circuit.

(Lower temperature helps liquidize the moisture.)

One of ways to lower the temperature is to make the piping at the inlet side of the water separator longer.

Long inlet side piping helps the release of the heat.

-3-

2) Prevention for solid obstruction entering into the water separator  
If large amount of solid obstruction (sand, rust) is intruded into the air flowing into the water separator, the obstruction may stack on the bowl and cause the operating failure of the auto drain and the drain cock, and air leakage. However, the intrusion of the obstruction into the water separator can be prevented by setting the air filter of the main line filter to the inlet side of the water separator.

#### MAINTENANCE

Although element replacement is basically unnecessary, extremely dirty air might cause clogging due to deteriorated oil or rust. Replacement is necessary in that case. (When pressure drop reach 0.1MPa)

Element (gasket, o-ring accessory) model number: AMG-EL\*\*\*

\*\*\* is AMG size symbol. (Ex: AMG-EL150)

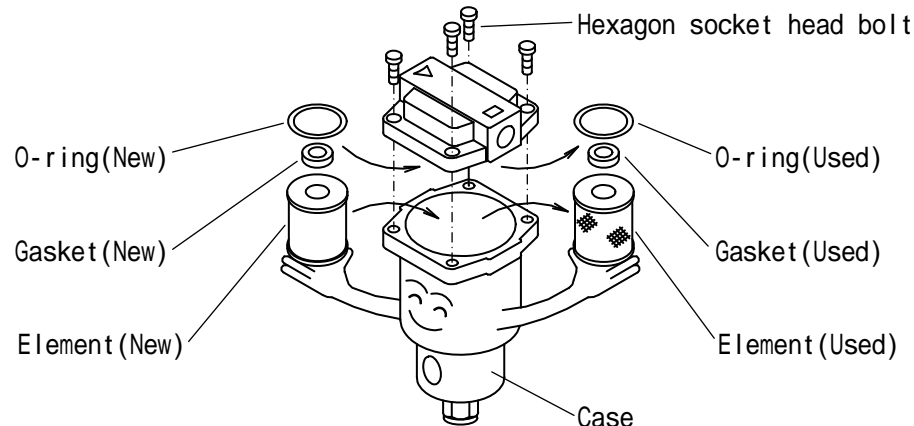

【How to replace element】

**First, discharge the pressure in the body. (Make pressure 0 MPa)**

Remove four hexagon socket head bolt.

Replace element, gasket, o-ring. Tighten hexagon socket head bolt.

Reference table production no. showing production month and year of a filter. (LX 2007.10)

SYMBOL	J	K	L	M	N	o	P	Q	R	S	T	U
Year	2005	2006	2007	2008	2009	2010	2011	2012	2013	2014	2015	2016
SYMBOL	o	P	Q	R	S	T	U	V	W	X	y	Z
Month	Jan	Feb	Mar	Apr	May	Jun	Jul	Aug	Sep	Oct	Nov	Dec

SMC CORPORATION

AMX - OM - F 0 0 5 - C

-4-