



## Installation Instructions: Tsunami Filtration



### WARNING

Your safety is important. System pressure must be released prior to any installation or service. Failure to follow instructions could result in operating failure or product damage. Always install filtration with the arrows indicating the direction of airflow. Use only appropriate thread sealant on all connection fittings unless otherwise specified. Do not alter the filtration from its original design as this may cause failure in its operation parameters.

### DESCRIPTION

Tsunami filters are machined from the highest quality materials & anodized inside & out to ensure ultimate durability against trapped contaminants. Our cutting-edge technology is rigorously tested to outperform your expectations regardless of the industry or application.

- Water Separators remove water and up to 1 quart per minute & filters particulate down to 10 micron.
- Oil Coalescing Filters remove oil aerosols down to .001 ppm & traps particulates down to .01 micron.
- Activated Carbon Filters remove oil vapor down to .003 ppm, removing odor & taste from the air.

### FILTER SPECIFICATIONS

	20 Series	50 Series	120 Series	240 Series	800 Series
Maximum Pressure	250 psi				200 psi
Maximum Flow (scfm)	20	50	120	240	800
Maximum Temp (°F)	175				
Port Size (npt)	1/4"	1/2"	1"	2"	3"

Note: Tsunami regulators have a maximum temperature of 122°F

### INSTALLATION & SERVICE REQUIREMENTS

**IMPORTANT:** The follow maintenance schedule is recommended for all Tsunami Filters and Filtration Packages. **Failure to follow instructions could result in operating failure or product damage.**

- Oil Coalescing Filter - Mandatory Every 6 Months
- Activated Carbon - Mandatory Every 6 Months
- Water Separator - Zero Maintenance Required. Clean as needed.

Tsunami filters come standard with automatic float drains. If ordered with pneumatic or electronic drains, follow the respected installation procedures listed here:

**Pneumatic:** Run pilot line from bottom nipple of filter drain to desired pilot signal. Drain line runs out of side port.

**Electronic:** Plug 110v cord into wall.

### FILTER INSTALLATION - OPTION 1 - MOUNTING BRACKET

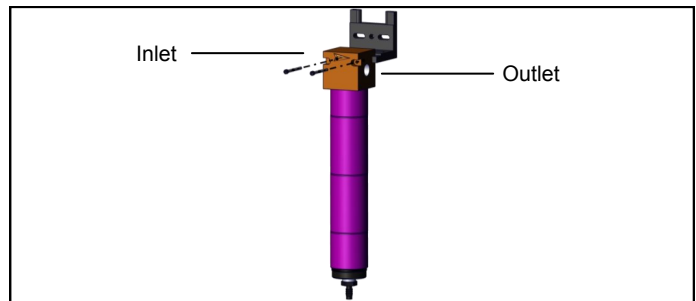

1. If using a Tsunami filter *Mounting Bracket*, secure bracket to wall prior to plumbing filter into air system.
2. Using supplied hardware, attach Tsunami filter to mounting bracket.
3. Using arrow on filter head, plumb unit into system piping in the desired direction of airflow. Use appropriate thread sealant.

### FILTER INSTALLATION - OPTION 2 - MOUNTING PANEL



1. If using a Tsunami filter package *Mounting Panel*, secure panel to wall prior to plumbing filter package into air system.
2. Using arrows on filter heads, plumb unit into system piping in the desired direction of airflow. Use appropriate thread sealant.

### FILTER INSTALLATION - OPTION 3 - MOUNTING INLINE

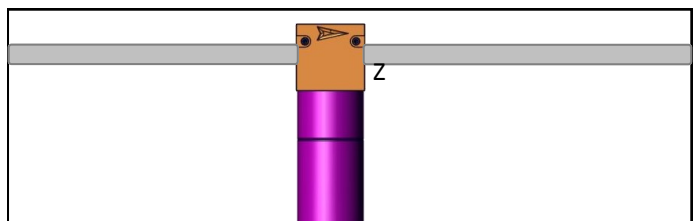

1. If installing filter directly inline with air system plumbing, verify that there is adequate support to hold weight of filter. For filter models including electronic drains, verify there is adequate space between the wall and filter to allow for removal of tube during maintenance.
2. Using arrow on filter head, plumb unit into system piping in the desired direction of airflow. Use appropriate thread sealant.

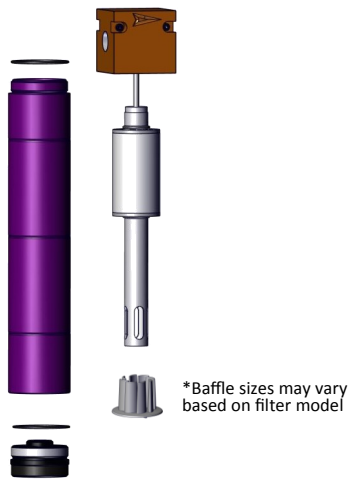

Figure #1: Water Separator



Figure #2: Oil Coalescing Filter



Figure #3: Activated Carbon

## Service Part Number Guide

	Water Separator Service Kit	Oil Coalescing Filter Service Kit	(5 Pack) Coalescing Elements	Activated Carbon Kit	(5 Pack) Activated Carbon Elements	(3 Pack) Float Drain	Pneumatic Drain	Electronic Drain
20 Series	21999-0846	21999-0394	21999-0823	21999-0395	21999-0824	21999-0868	21999-0792	21999-0177
50 Series	21999-0227	21999-0202	21999-0825	21999-0200	21999-0826	21999-0868	21999-0795	21999-0177
120 Series	21999-0228	21999-0202	21999-0825	-	-	21999-0868	21999-0805	21999-0177
240 Series	21999-0228 (x2)	21999-0202 (x2)	21999-0825 (x2)	-	-	21999-0868	21999-0805 (x2)	21999-0177 (x2)
800 Series	21999-1005	-	-	-	-	21999-0868	152-0000	21999-0177

## WARNING

Your safety is important. System pressure must be released prior to any installation or service. Failure to follow instructions could result in operating failure or product damage. Always install filtration with the arrows indicating the direction of airflow. Use only appropriate thread sealant on all connection fittings unless otherwise specified. Do not alter the filtration from its original design as this may cause failure in its operation parameters.

### WATER SEPARATOR MAINTENANCE

1. Release system pressure.
2. Remove tube from filter head by holding filter head and rotating tube counter-clockwise.
3. Using a 5/16" or 3/8" wrench, remove baffle from threaded rod below element.
4. Remove bottom baffle, filter element, top adaptor (120 & 240 Series Filters Only), and O-ring.
5. Clean stainless steel mesh with soapy water or replace entire element with service kit. Refer to Service Chart shown above.
6. Replace filter element and hardware in reverse order from previous steps. Tighten baffle until filter element can no longer spin freely. DO NOT OVER TIGHTEN!
7. Reinstall outer tube by rotating clockwise onto filter head.
8. Slowly pressurize the unit.

### OIL COALESCER / ACTIVATED CARBON MAINTENANCE

1. Release system pressure.
2. Remove tube from filter head by holding filter head and rotating tube counter-clockwise.
3. Using a 5/16" or 3/8" wrench, remove baffle from threaded rod below element.
4. Remove bottom baffle, filter element (element gaskets, 20 Series only), top adaptor, and O-ring.
5. Replace filter element and hardware in reverse order from previous steps. Tighten baffle until filter element can no longer spin freely. DO NOT OVER TIGHTEN!
6. Reinstall outer tube by rotating clockwise onto filter head.
7. Slowly pressurize the unit.

### DRAIN REPLACEMENT INSTRUCTIONS

#### Float Drain

1. Release system pressure.
2. Remove bottom cap by holding filter tube and rotating bottom cap counter-clockwise.
3. Grasp float drain by stem and rotate counter-clockwise.
4. Reinstall new float drain by spinning in clockwise direction until O-ring contacts the end cap. Tighten an additional 1/4 turn. DO NOT OVER TIGHTEN!
5. Reinstall end cap on filter tube.
6. Slowly pressurize system.

#### Pneumatic Drain

1. Release system pressure.
2. Disconnect pilot line tubing.
3. Remove pneumatic drain by holding filter tube and rotating pneumatic drain counter-clockwise.
4. Reinstall new drain by spinning in clockwise direction. DO NOT OVERTIGHTEN!
5. Reconnect pilot line tubing.
6. Slowly pressurize system.

#### Electronic Drain

1. Release system pressure.
2. Drain from power source.
3. Remove electronic drain by holding filter end cap and rotating counter-clockwise.
4. Reinstall new drain by spinning in clockwise direction. DO NOT OVERTIGHTEN!
5. Reconnect to power source.
6. Slowly pressurize system.